

Catalogo Gearless *Gearless Catalogue*

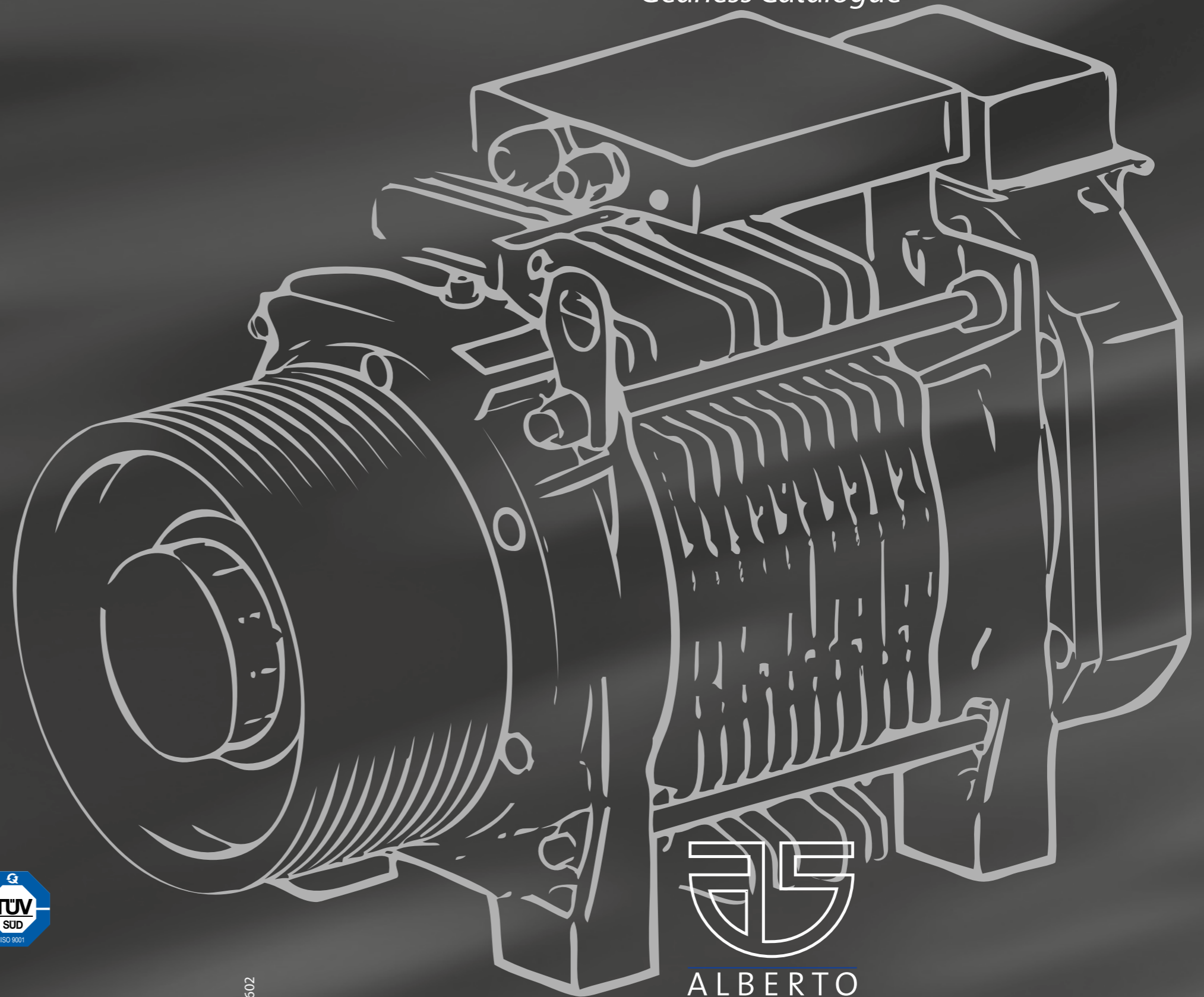

* I dati riportati sono indicativi e non sono impegnativi. I prodotti presentati possono, in ogni momento e senza preavviso, subire modifiche.

* The data are not binding.
The items featured in this catalogue may be changed without previous notice.

 **ALBERTO SASSI** ASTOR
HIGHER LIFT TECHNOLOGY



ALBERTO SASSI S.p.A. (GRUPPO SASSI HOLDING)
Offices and Factory - Via Guido Rossa, 1
Loc. Crespellano - 40053 Valsamoggia (BO) Italy
Tel. +39 051 6720202 - Fax +39 051 6720244
www.sassi.it - e-mail: sassi@sassi.it

INSE0000602



ALBERTO SASSI
HIGHER LIFT TECHNOLOGY

2	G-100 T0•T1	45	G-400 T3
6	G-180	62	G-500 T1•T2
8	G-180 TC	74	Telmo
18	G-200 T1•TS•TC	77	Telai con gearless <i>Frame -set with gearless</i>
26	G-300 T0•TS•TC	82	Fidopak
27	G-300 T1•T2	84	Ecobrake
44	G-400 T1•T2	84	Accessori/Accessories

Aggiornamento dati nel sito www.sassi.it • Updated data in www.sassi.it

Contatti/ Contact:

ALBERTO SASSI S.p.A. Via Guido Rossa, 1 Loc. Crespellano 40053
Valsamoggia BO (Italy) - Tel +39 051 6720202

Ufficio commerciale / Sales Department: email: sales@sassi.it
fax: +39 051 6720244

Ufficio Assistenza post vendita / After Sales Department:
email: aftersales@sassi.it - fax: +39 051 969468

Ufficio Tecnico / Technical Department: email: tech@sassi.it
fax: +39 051 6720136

Per ordini / For orders: sales@sassi.it

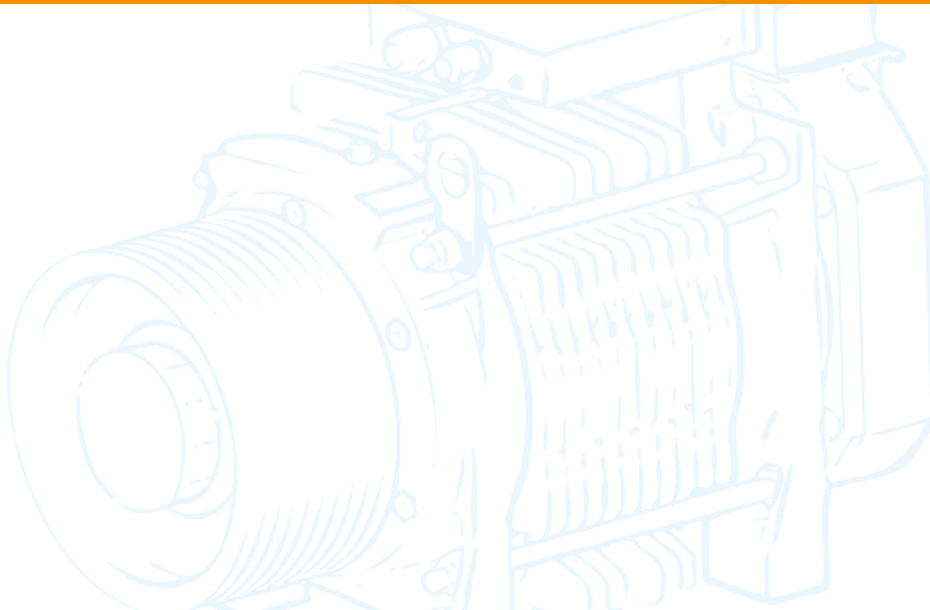

TUTTI I DIRITTI RISERVATI.

I disegni raccolti nel presente catalogo restano di ns. esclusiva proprietà. Riproduzione, anche parziale, vietata. I dati riportati sono indicativi e non sono impegnativi. I prodotti presentati possono, in ogni momento e senza preavviso, subire modifiche.

ALL RIGHTS RESERVED.

The drawings enclosed in this technical catalogue remain our sole property. Entire and/or partial reproduction is prohibited. The data are not binding. The items featured in this catalogue may be changed without previous notice.

ALLE RECHTE VORBEHALTEN.

Die Zeichnungen dieses Kataloges bleiben unser Eigentum. Voll-oder unvollständige Nachdrucke sind verboten. Die Angaben sind unverbindlich. Änderungen sind vorbehalten.

TODOS LOS DERECHOS RESERVADOS.

Los diseños en el presente catalogo son de nuestra exclusiva propiedad. Reproducción, aunque sea parcial está prohibida. Los datos incluidos son a título indicativos y no son vinculantes. Los productos presentados pueden, en cualquier momento y sin aviso anticipado, sufrir modificaciones.

TOUS DROITS RESERVÉS.

Les dessins reproduits dans ce catalogue sont de notre propriété. Reproduction meme partielle interdite. Les données indiquées sont à titre d'indication et ne sont pas engageantes. Les produits présentés sur ce catalogue peuvent subir en n'importe quel moment, et sans preavis, des modifications.



G-100 T0·T1

G-100 T0

Senza ventole di raffreddamento / Without cooling fans

Carico statico / <i>Static load</i> [kg]	1000		
Coppia / <i>Rated torque</i> [Nm]	90		
Peso / <i>Weight</i> [kg]	90		
Tensione / <i>Voltage</i> [V]	220		
Portata / <i>Duty load</i> [kg]	225	300	400
Tiro / <i>Suspension</i>	2/1		
Gamma velocità cabina <i>Range of cabin speed</i> [m/s]	0,15 ÷ 0,50		
Gamma Ø pulegge <i>Range sheave Ø</i> [mm]	120 - 140 - 160	120 - 140 - 160	120
Max combinazione funi <i>Max ropes combination</i> [mm]	7 ø 6,5		

20 Poles

G-100 T1

Senza ventole di raffreddamento / Without cooling fans

Carico statico / <i>Static load</i> [kg]	1600					
Coppia / <i>Rated torque</i> [Nm]	140					
Peso / <i>Weight</i> [kg]	105					
Tensione / <i>Voltage</i> [V]	220					
Portata / <i>Duty load</i> [kg]	225	300	400	450	525	630
Tiro / <i>Suspension</i>	1/1	1/1	2/1	2/1	2/1	2/1
Gamma velocità cabina <i>Range of cabin speed</i> [m/s]	0,15 ÷ 0,50	0,15 ÷ 0,50	0,15 ÷ 0,50	0,15 ÷ 0,50	0,15 ÷ 0,50	0,15 ÷ 0,50
Gamma Ø pulegge <i>Range sheave Ø</i> [mm]	120 - 140 - 160	120	120 - 140 - 160	120 - 140 - 160	120 - 140	120
Max combinazione funi <i>Max ropes combination</i> [mm]	7 ø 6,5					

20 Poles



G-100 T0 • T1 Senza ventilatori / Without cooling fans

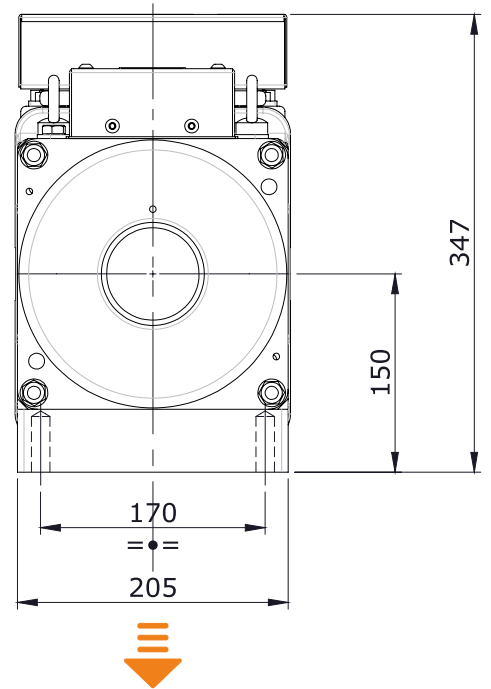
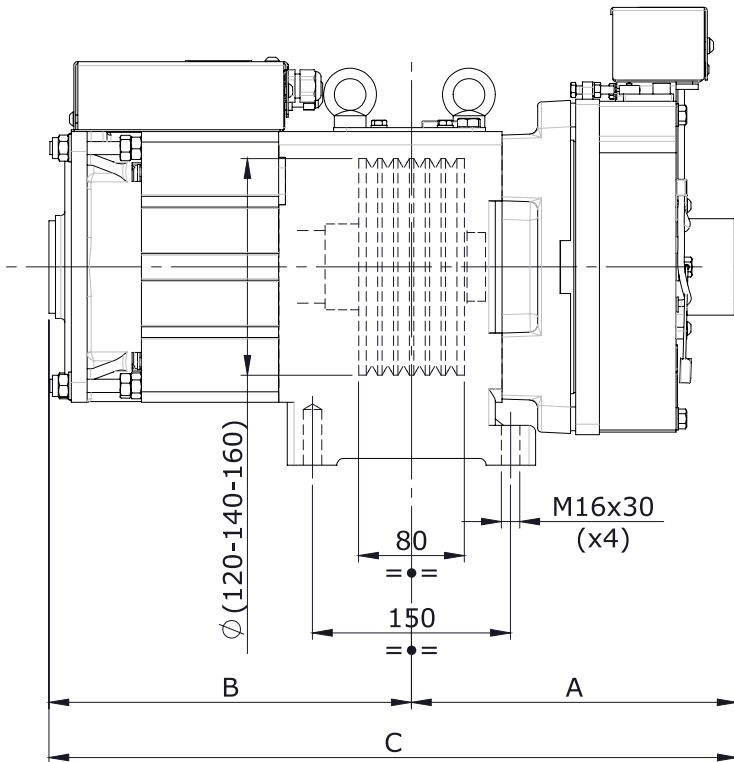

Unica direzione per l'uscita delle funi
Sole direction for ropes' exit

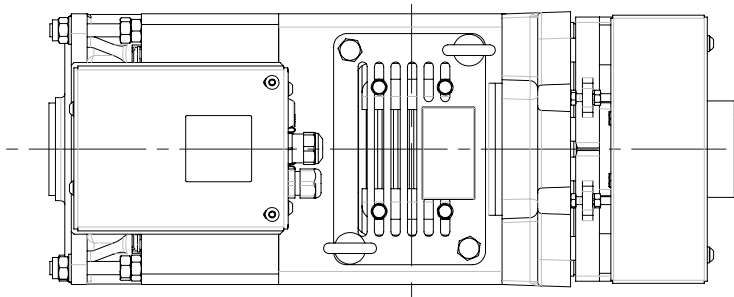

Dimensioni / Dimensions [mm]	G-100 T0	G-100 T1
A	247	247
B	275	325
C	522	572
FRENI / BRAKES	DGA1	DG01



Tiro Roping Factor	Peso funi max Max Ropes Weight [kg]	Portata Duty Load [kg]	Velocità cabina Cabin Speed [m/s]	Ø Puleggia Sheave Diameter [mm]	Poli Poles	Velocità Speed [rpm]	Frequenza Frequency [Hz]	Efficienza vano Shaft Efficiency	Coppia Torque [Nm]	Potenza in uscita Power Output [kW]
	(1) (2)			(3)						
2	20	225	0,15	120	20	47,7	7,96	0,85	53	0,26
2	20	225	0,15	140	20	40,9	6,82	0,85	62	0,26
2	20	225	0,15	160	20	35,8	5,97	0,85	70	0,26
2	20	225	0,3	120	20	95,5	15,92	0,85	53	0,53
2	20	225	0,3	140	20	81,9	13,64	0,85	62	0,53
2	20	225	0,3	160	20	71,6	11,94	0,85	70	0,53
2	20	225	0,5	120	20	159,2	26,53	0,85	53	0,88
2	20	225	0,5	140	20	136,4	22,74	0,85	62	0,88
2	20	225	0,5	160	20	119,4	19,89	0,85	70	0,88
2	20	300	0,15	120	20	47,7	7,96	0,85	66	0,33
2	20	300	0,15	140	20	40,9	6,82	0,85	77	0,33
2	20	300	0,15	160	20	35,8	5,97	0,85	88	0,33
2	20	300	0,3	120	20	95,5	15,92	0,85	66	0,66
2	20	300	0,3	140	20	81,9	13,64	0,85	77	0,66
2	20	300	0,3	160	20	71,6	11,94	0,85	88	0,66
2	20	300	0,5	120	20	159,2	26,53	0,85	66	1,10
2	20	300	0,5	140	20	136,4	22,74	0,85	77	1,10
2	20	300	0,5	160	20	119,4	19,89	0,85	88	1,10
2	20	400	0,15	120	20	47,7	7,96	0,85	83	0,42
2	20	400	0,3	120	20	95,5	15,92	0,85	83	0,83
2	20	400	0,5	120	20	159,2	26,53	0,85	83	1,38

C_Max [Nm] = 90

G-100 T0 - NOTES

Brake Type: DGA1 - Standard 205 VDC - Other voltages on request.

Encoder Type: Absolute Heidenhain with EnDat Interface - Other type on request.

Note (1): For use in Homelift application.

Note (2): For higher ropes weight, please consult sales/technical services of Alberto Sassi SpA.

Note (3): Suitable for steel core ropes or also for coated ropes.

Note (4): DGXY certified brake against Overspeed in upward direction and as UCM (EN 81-20:2014, EN 81-50:2014) with reference to Lift Directive 2014/33/EU.

Note (5): 1000 kg as Max Static Load. Max 90 sts/h - 20% ED without fans.

Note (6): Weight 90 kg.

The Alberto Sassi SpA reserves the rights to change data and features without previous notice.



Tiro <i>Roping Factor</i>	Peso funi max <i>Max Ropes Weight</i> [kg]	Portata <i>Duty Load</i> [kg]	Velocità cabina <i>Cabin Speed</i> [m/s]	Ø Puleggia <i>Sheave Diameter</i> [mm]	Poli <i>Poles</i>	Velocità <i>Speed</i> [rpm]	Frequenza <i>Frequency</i> [Hz]	Efficienza vano <i>Shaft Efficiency</i>	Coppia <i>Torque</i> [Nm]	Potenza in uscita <i>Power Output</i> [kW]
	(1) (2)			(3)						
1	30	225	0,15	120	20	23,9	3,98	0,85	99	0,2
1	30	225	0,15	140	20	20,5	3,41	0,85	115	0,2
1	30	225	0,15	160	20	17,9	2,98	0,85	132	0,2
1	30	225	0,3	120	20	47,7	7,96	0,85	99	0,5
1	30	225	0,3	140	20	40,9	6,82	0,85	115	0,5
1	30	225	0,3	160	20	35,8	5,97	0,85	132	0,5
1	30	225	0,5	120	20	79,6	13,26	0,85	99	0,8
1	30	225	0,5	140	20	68,2	11,37	0,85	115	0,8
1	30	225	0,5	160	20	59,7	9,95	0,85	132	0,8
1	30	300	0,15	120	20	23,9	3,98	0,85	125	0,3
1	30	300	0,3	120	20	47,7	7,96	0,85	125	0,6
1	30	300	0,5	120	20	79,6	13,26	0,85	125	1,0
2	30	450	0,15	120	20	47,7	7,96	0,85	99	0,5
2	30	450	0,15	140	20	40,9	6,82	0,85	115	0,5
2	30	450	0,15	160	20	35,8	5,97	0,85	132	0,5
2	30	450	0,3	120	20	95,5	15,92	0,85	99	1,0
2	30	450	0,3	140	20	81,9	13,64	0,85	115	1,0
2	30	450	0,3	160	20	71,6	11,94	0,85	132	1,0
2	30	450	0,5	120	20	159,2	26,53	0,85	99	1,6
2	30	450	0,5	140	20	136,4	22,74	0,85	115	1,6
2	30	450	0,5	160	20	119,4	19,89	0,85	132	1,6
2	30	525	0,15	120	20	47,7	7,96	0,85	112	0,6
2	30	525	0,15	140	20	40,9	6,82	0,85	130	0,6
2	30	525	0,3	120	20	95,5	15,92	0,85	112	1,1
2	30	525	0,3	140	20	81,9	13,64	0,85	130	1,1
2	30	525	0,5	120	20	159,2	26,53	0,85	112	1,9
2	30	525	0,5	140	20	136,4	22,74	0,85	130	1,9
2	30	630	0,15	120	20	47,7	7,96	0,85	130	0,6
2	30	630	0,3	120	20	95,5	15,92	0,85	130	1,3
2	30	630	0,5	120	20	159,2	26,53	0,85	130	2,2

C_Max [Nm] = 140**G-100 T1 - NOTES****Brake Type:** DG01 - Standard 205 VDC - Other voltages on request.**Static Load:** 1600 kg.**Encoder Type:** Absolute encoder with EnDat Interface - Other type on request.**Note 1:** For use in Homelift application.**Note 2:** For higher ropes weight, please consult sales/technical services of Alberto Sassi SpA.**Note 3:** Suitable for steel core ropes or also for plastic coated ropes.**Note 4:** DGXY certified brake against Overspeed in upward direction and as UCM (EN 81-20:2014, EN 81-50:2014) with reference to Lift Directive 2014/33/EU.**Note 5:** Max 90 sts/h - 20% ED without fans.**Note 6:** Weight 105 kg.*The Alberto Sassi SpA reserves the rights to change data and features without previous notice.*

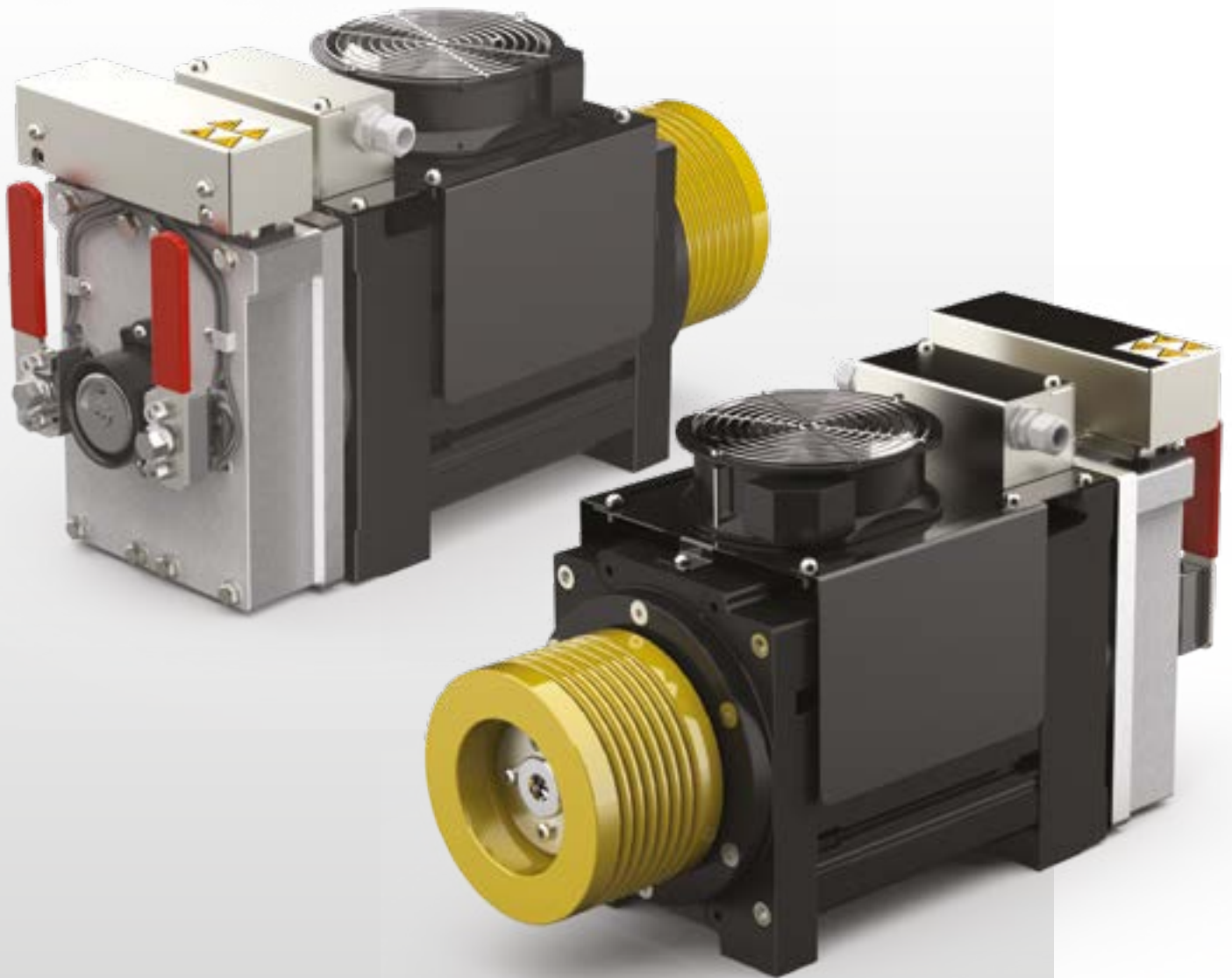

G-180

Con ventole di raffreddamento / With cooling fans

TIPO / TYPE	G-180 T2			G-180 T3				G-180 T4			G-180 T5			G-180 T6		
Carico statico / Static load [kg]	2350			2350				2350/2000*			2350/2000*			2350/2000*		
Coppia / Rated torque [Nm]	90			140				180			218			270		
Peso / Weight [kg]	92			104				110			116			128		
Portata / Duty load	225	300	375	300	450	525	630	450	630	800	450	800	1000	525	800	1000
Tiro / Suspension	2/1	2/1	2/1	1/1	2/1	2/1	2/1	1/1	2/1	2/1	1/1	2/1	2/1	1/1	2/1	2/1
Gamma velocità cabina / Range of cabin speed [m/s]	0,15 ÷ 1,00			0,15 ÷ 1,60				0,6 ÷ 1,60			0,6 ÷ 1,60			0,6 ÷ 1,60		
Gamma Ø pulegge / Range sheave Ø [mm]	120	120	120	120	120	120	120	120	120	120	120	120	120	120	120	120
	140	140		140	140	140		140	140		140	140		140	140	140
	160	160		160	160	160		160	160		160	160		160	160	160
Larghezza pulegge / Sheave width [mm]	75			75				75/105*			75/105*			75/105*		
Max combinazione funi / Max ropes combination [mm]	n. 6 ø 6,5			n. 6 ø 6,5				n. 9 ø 6,5			n. 9 ø 6,5			n. 9 ø 6,5		

20 Poles



G-180 con ventole di raffreddamento / With cooling fans

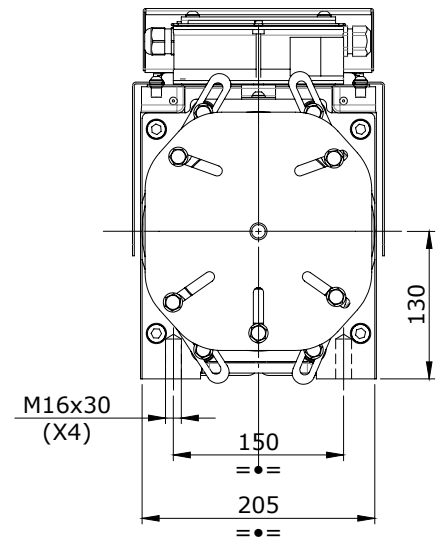
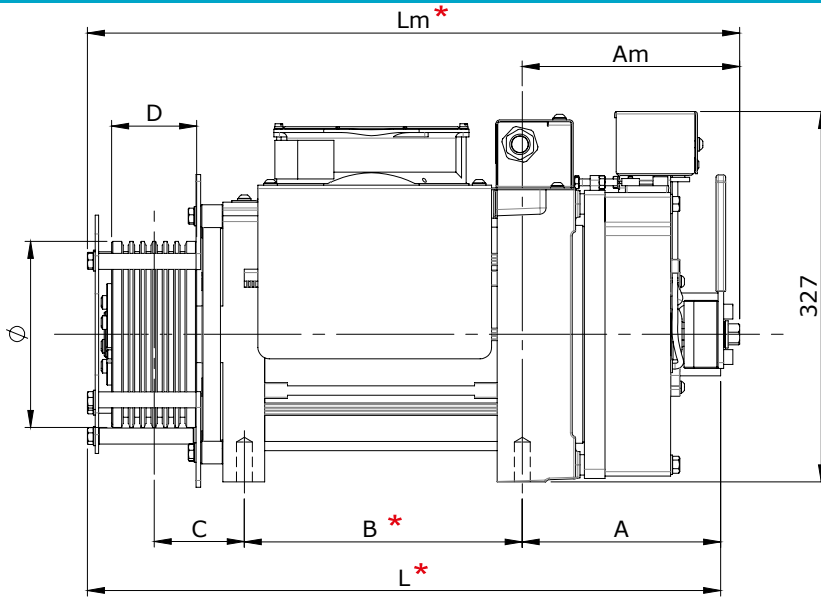

without cooling fans

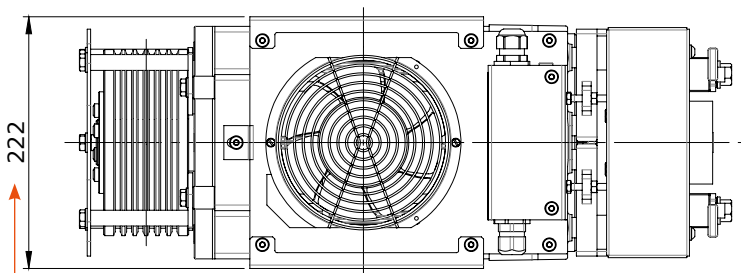

(with optional lateral carter)

* Tolerance $\pm 2\text{mm}$

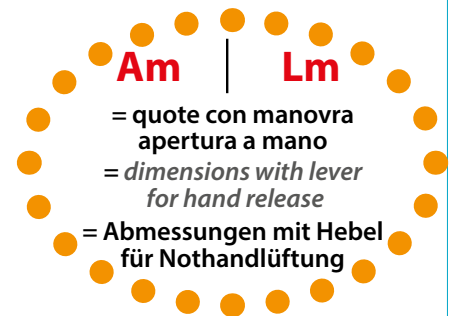

Dimensioni / Dimensions [mm]	G-180 T2	G-180 T3	G-180 T4	G-180 T5	G-180 T6
A	175	175	175	175	197
L	457	507	558 / 581	610 / 633	682 / 705
Am	192	192	192	192	214
Lm	474	524	575 / 598	627 / 650	700 / 723
B	144	194	245	297	347
C	80	80	80 / 95	80 / 95	80 / 95
D	75	75	75 / 105	75 / 105	75 / 105
Ø	120 - 140 - 160		120 - 140 - 160 - 200		
FRENI / BRAKES	DGA1	DG01	DG01	DG01	DG02

G-180 TC Gearless

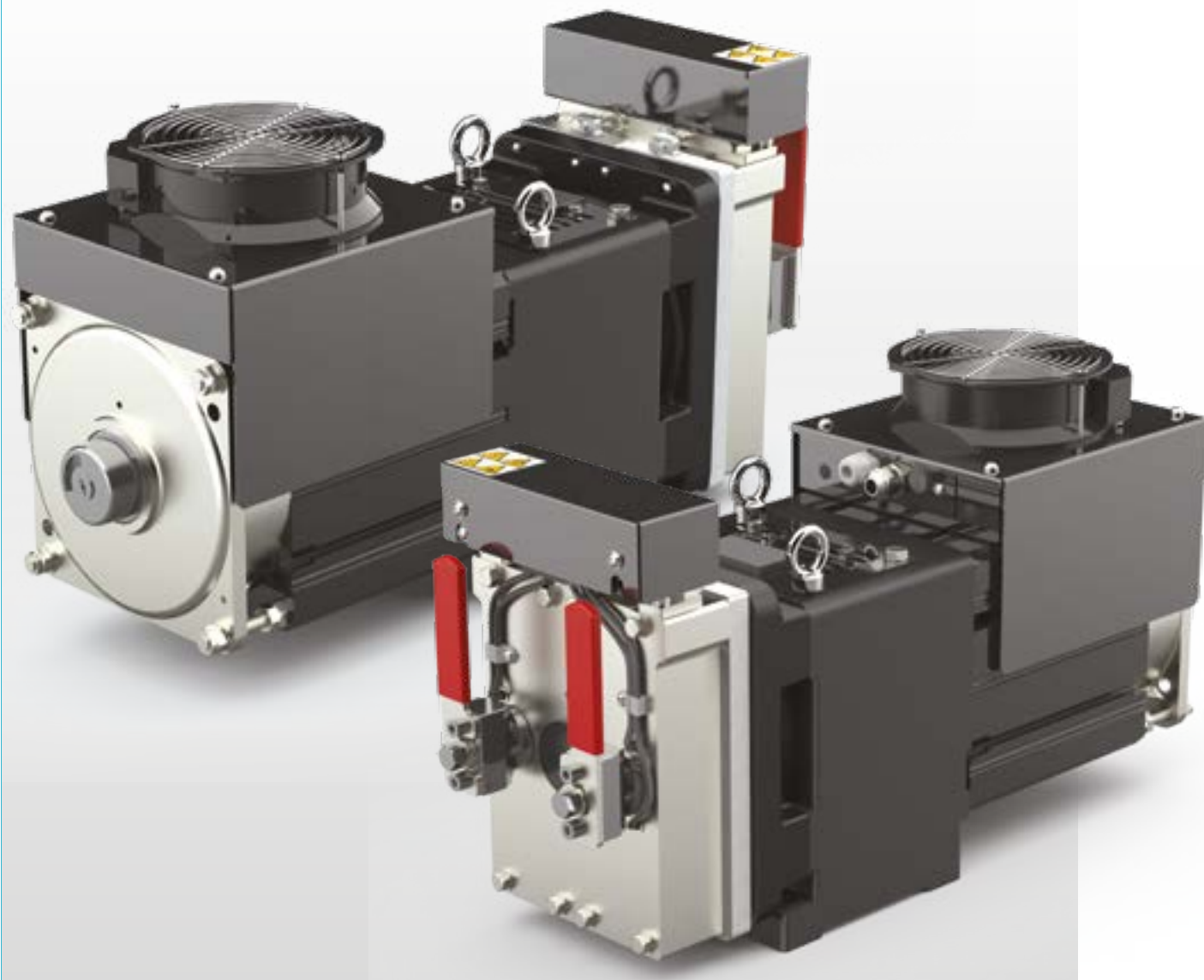

G-180 TC		Con ventole di raffreddamento / With cooling fans								
TIPO / TYPE	G-180 C2			G-180 C3			G-180 C4			
Carico statico / Static load [kg]	2000									
Coppia / Rated torque [Nm]	90			140			180			
Peso / Weight [kg]	93			108			124			
Portata / Duty load	225	300	375	300	450	630	450	630	800	
Tiro / Suspension	1/1	2/1	2/1	1/1	2/1	2/1	1/1	2/1	2/1	
Gamma velocità cabina / Range of cabin speed [m/s]	0,15 ÷ 1,00			0,15 ÷ 1,00			0,15 ÷ 1,60			
Gamma Ø pulegge / Range sheave Ø [mm]	120 140 160	120 140 160	120	120	120 140 160	120 140	120	120 140 160	120	
Larghezza pulegge / Sheave width [mm]	80									
Max combinazione funi Max ropes combination [mm]	n. 6 ø 6,5			n. 6 ø 6,5			n. 7 ø 6,5			
20 Poles										



G-180 TC con ventole di raffreddamento / With cooling fans

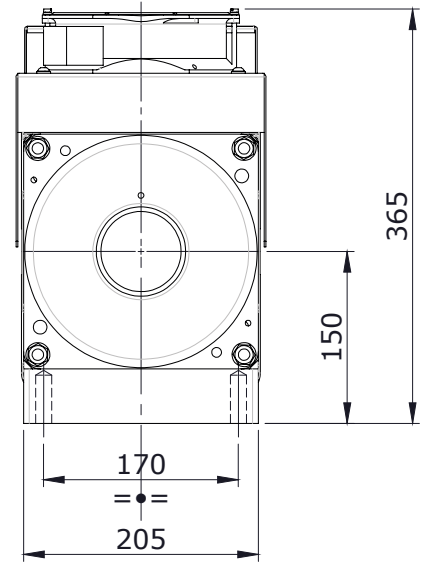
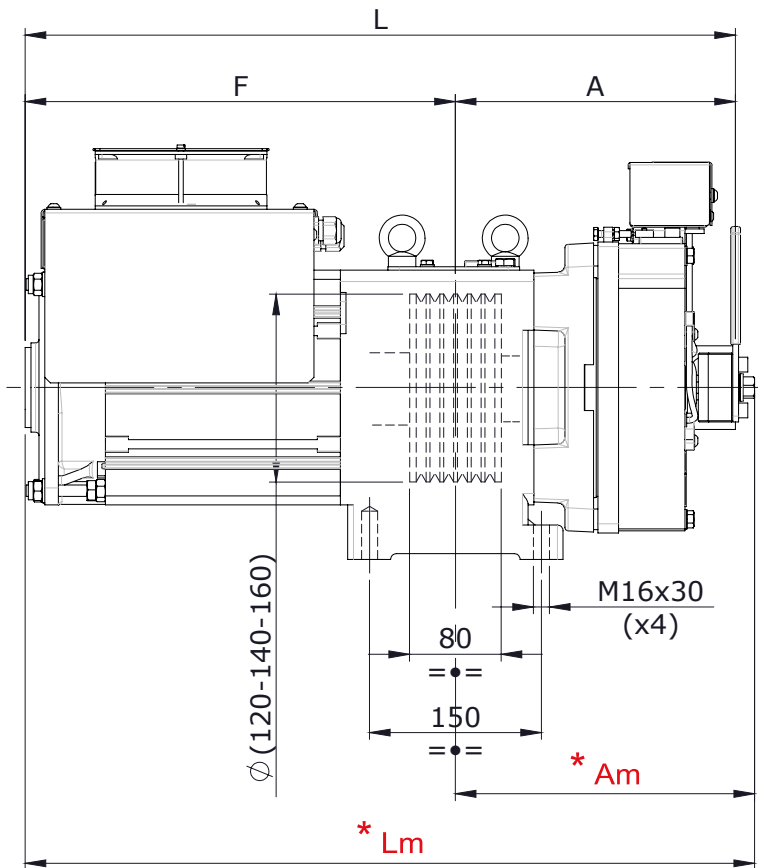

 Unica direzione per l'uscita delle funi
 Sole direction for ropes' exit

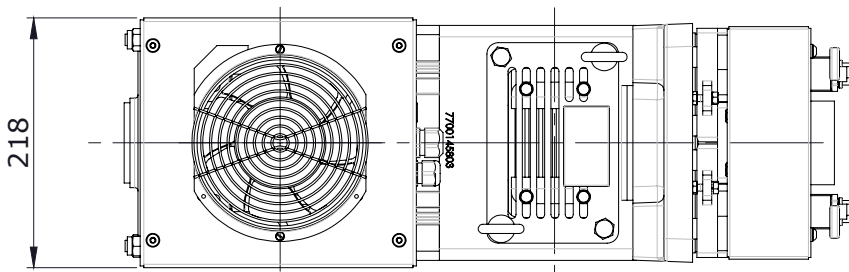

Am | **Lm**
 = quote con manovra apertura a mano
 = dimensions with lever for hand release
 = Abmessungen mit Hebel für Nothandlüftung

Dimensioni / Dimensions [mm]	G-180 C2	G-180 C3	G-180 C4
A	247	247	247
L	525	574	623
Am	261	261	261
Lm	539	588	637
F	278	327	376
Ø	120 - 140 - 160		
FRENI / BRAKES	DGA1	DG01	DG01



Tiro	Peso funi max	Portata	Velocità cabina	Ø Puleggia	Poli	Velocità	Frequenza	Efficienza vano	Coppia	Potenza in uscita
Roping Factor	Max Ropes Weight [kg]	Duty Load [kg]	Cabin Speed [m/s]	Sheave Diameter [mm]	Poles	Speed [rpm]	Frequency [Hz]	Shaft Efficiency	Torque [Nm]	Power Output [kW]
	(1)			(2) (3)				(4)		
1	30	180	0,6	120	20	95,5	15,92	0,85	83	0,8
1	30	180	0,8	120	20	127,3	21,22	0,85	83	1,1
1	30	180	1	120	20	159,2	26,53	0,85	83	1,4
2	30	180	0,6	120	20	191,0	31,83	0,85	52	1,0
2	30	180	0,6	140	20	163,7	27,28	0,85	61	1,0
2	30	180	0,6	160	20	143,2	23,87	0,85	69	1,0
2	30	180	0,8	120	20	254,6	42,44	0,85	52	1,4
2	30	180	0,8	140	20	218,3	36,38	0,85	61	1,4
2	30	180	0,8	160	20	191,0	31,83	0,85	69	1,4
2	30	180	1	120	20	318,3	53,05	0,85	52	1,7
2	30	180	1	140	20	272,8	45,47	0,85	61	1,7
2	30	180	1	160	20	238,7	39,79	0,85	69	1,7
2	30	225	0,6	120	20	191,0	31,83	0,85	60	1,2
2	30	225	0,6	140	20	163,7	27,28	0,85	70	1,2
2	30	225	0,6	160	20	143,2	23,87	0,85	80	1,2
2	30	225	0,8	120	20	254,6	42,44	0,85	60	1,6
2	30	225	0,8	140	20	218,3	36,38	0,85	70	1,6
2	30	225	0,8	160	20	191,0	31,83	0,85	80	1,6
2	30	225	1	120	20	318,3	53,05	0,85	60	2,0
2	30	225	1	140	20	272,8	45,47	0,85	70	2,0
2	30	225	1	160	20	238,7	39,79	0,85	80	2,0
2	30	300	0,6	120	20	191,0	31,83	0,85	73	1,5
2	30	300	0,6	140	20	163,7	27,28	0,85	85	1,5
2	30	300	0,8	120	20	254,6	42,44	0,85	73	1,9
2	30	300	0,8	140	20	218,3	36,38	0,85	85	1,9
2	30	300	1	120	20	318,3	53,05	0,85	73	2,4
2	30	300	1	140	20	272,8	45,47	0,85	85	2,4
2	30	375	0,6	120	20	191,0	31,83	0,85	86	1,7
2	30	375	0,8	120	20	254,6	42,44	0,85	86	2,3
2	30	375	1	120	20	318,3	53,05	0,85	86	2,9

C_Max [Nm] = 90

G-180 T2•C2 - NOTE

Brake Type: DGA1 - Standard 205 V DC - Other voltages on request.

Static Load: G-180 T2: 2350 kg.

G-180 C2: 2000 kg.

Encoder Type: Absolute encoder with EnDat Interface or Incremental sin/cos, both with 2048 ppr;

Note 1: For higher ropes weight, please consult sales/technical services of Alberto Sassi SpA.

Note 2: Details on ropes/grooves provided upon lift data.

Note 3: Suitable for steel core ropes or also for plastic coated ropes.

Note 4: Shaft efficiency includes divertor pulleys efficiency by considering: 3 divertors for roping 2:1. Values are supposed.

Note 5: Max 90 sts/h - 20% ED without fans.
Max 180 sts/h - 40% ED with fans activated by thermocontacts inside motor.

Note 6: DGXY certified brake against Overspeed in upward direction and as UCM (EN 81-20:2014, EN 81-50:2014) with reference to Lift Directive 2014/33/EU.

Note 7: G-180 T2: Traction sheave width 75 mm.
G-180 C2: Traction sheave width 80 mm.

Note 8: G-180 T2: Weight 92 kg.
G-180 C2: Weight 93 kg.

The Alberto Sassi SpA reserves the rights to change data and features without previous notice.



Tiro Roping Factor	Peso funi max Max Ropes Weight [kg]	Portata Duty Load [kg]	Velocità cabina Cabin Speed [m/s]	Ø Puleggia Sheave Diameter [mm]	Poli Poles	Velocità Speed [rpm]	Frequenza Frequency [Hz]	Efficienza vano Shaft Efficiency	Coppia Torque [Nm]	Potenza in uscita Power Output [kW]
	(1)			(2) (3)				(4)		
1	30	225	0,6	120	20	95,5	15,92	0,85	99	1,0
1	30	225	0,6	140	20	81,9	13,64	0,85	115	1,0
1	30	225	0,6	160	20	71,6	11,94	0,85	132	1,0
1	30	225	0,8	120	20	127,3	21,22	0,85	99	1,3
1	30	225	0,8	140	20	109,1	18,19	0,85	115	1,3
1	30	225	0,8	160	20	95,5	15,92	0,85	132	1,3
1	30	225	1	120	20	159,2	26,53	0,85	99	1,6
1	30	225	1	140	20	136,4	22,74	0,85	115	1,6
1	30	225	1	160	20	119,4	19,89	0,85	132	1,6
1	30	300	0,6	120	20	95,5	15,92	0,85	125	1,2
1	30	300	0,8	120	20	127,3	21,22	0,85	125	1,7
1	30	300	1	120	20	159,2	26,53	0,85	125	2,1
2	30	300	0,6	120	20	191,0	31,83	0,85	73	1,5
2	30	300	0,6	140	20	163,7	27,28	0,85	85	1,5
2	30	300	0,6	160	20	143,2	23,87	0,85	97	1,5
2	30	300	0,6	200*	20	114,5	19,10	0,85	121	1,5
2	30	300	0,8	120	20	254,6	42,44	0,85	73	1,9
2	30	300	0,8	140	20	218,3	36,38	0,85	85	1,9
2	30	300	0,8	160	20	191,0	31,83	0,85	97	1,9
2	30	300	0,8	200*	20	152,8	25,46	0,85	121	1,9
2	30	300	1	120	20	318,3	53,05	0,85	73	2,4
2	30	300	1	140	20	272,8	45,47	0,85	85	2,4
2	30	300	1	160	20	238,7	39,79	0,85	97	2,4
2	30	300	1	200*	20	191,0	31,83	0,85	121	2,4
2	30	450	0,6	120	20	191,0	31,83	0,85	99	2,0
2	30	450	0,6	140	20	163,7	27,28	0,85	115	2,0
2	30	450	0,6	160	20	143,2	23,87	0,85	132	2,0
2	30	450	0,8	120	20	254,6	42,44	0,85	99	2,6
2	30	450	0,8	140	20	218,3	36,38	0,85	115	2,6
2	30	450	0,8	160	20	191,0	31,83	0,85	132	2,6
2	30	450	1	120	20	318,3	53,05	0,85	99	3,3
2	30	450	1	140	20	272,8	45,47	0,85	115	3,3
2	30	450	1	160	20	238,7	39,79	0,85	132	3,3
2	30	525	0,6	120	20	191,0	31,83	0,85	112	2,2
2	30	525	0,6	140	20	163,7	27,28	0,85	130	2,2
2	30	525	0,8	120	20	254,6	42,44	0,85	112	3,0
2	30	525	0,8	140	20	218,3	36,38	0,85	130	3,0
2	30	525	1	120	20	318,3	53,05	0,85	112	3,7
2	30	525	1	140	20	272,8	45,47	0,85	130	3,7
2	30	630	0,6	120	20	191,0	31,83	0,85	130	2,6
2	30	630	0,8	120	20	254,6	42,44	0,85	130	3,5
2	30	630	1	120	20	318,3	53,05	0,85	130	4,3

G-180 T3•C3 - NOTE * Sheave diameter available only for G-180 T3. C_Max [Nm] = 140

Brake Type: DG01 - Standard 205 V DC - Other voltages on request.

Static Load: G-180 T3: 2350 kg.
G-180 C3: 2000 kg.

Encoder Type: Absolute encoder with EnDat Interface or Incremental sin/cos, both with 2048 ppr;

Note 1: For higher ropes weight, please consult sales/technical services of Alberto Sassi SpA.

Note 2: Details on ropes/grooves provided upon lift data.

Note 3: Suitable for steel core ropes or also for plastic coated ropes.

Note 4: Shaft efficiency includes diverter pulleys efficiency by considering: 3 divertors for roping 2:1. Values are supposed.

Note 5: Max 90 sts/h - 20% ED without fans.

Max 180 sts/h - 40% ED with fans activated by thermocontacts inside motor.

Note 6: DGXY certified brake against Overspeed in upward direction and as UCM (EN 81-20:2014, EN 81-50:2014) with reference to Lift Directive 2014/33/EU.

Note 7: G-180 T3: Traction sheave width 75 mm.
G-180 C3: Traction sheave width 80 mm.

Note 8: G-180 T3: Weight 104 kg.
G-180 C3: Weight 108 kg.

The Alberto Sassi SpA reserves the rights to change data and features without previous notice.

G-180 T4•C4 Gearless



Tiro	Peso funi max	Portata	Velocità cabina	Ø Puleggia	Poli	Velocità	Frequenza	Efficienza vano	Coppia	Potenza in uscita
Roping Factor	Max Ropes Weight [kg]	Duty Load [kg]	Cabin Speed [m/s]	Sheave Diameter [mm]	Poles	Speed [rpm]	Frequency [Hz]	Shaft Efficiency	Torque [Nm]	Power Output [kW]
	(1)			(2) (3)				(4)		
1	30	300	0,6	120	20	95,5	15,92	0,85	125	1,2
1	30	300	0,6	140	20	81,9	13,64	0,85	145	1,2
1	30	300	0,6	160	20	71,6	11,94	0,85	166	1,2
1	30	300	0,8	120	20	127,3	21,22	0,85	125	1,7
1	30	300	0,8	140	20	109,1	18,19	0,85	145	1,7
1	30	300	0,8	160	20	95,5	15,92	0,85	166	1,7
1	30	300	1	120	20	159,2	26,53	0,85	125	2,1
1	30	300	1	140	20	136,4	22,74	0,85	145	2,1
1	30	300	1	160	20	119,4	19,89	0,85	166	2,1
1	30	300	1,6	120	20	254,6	42,44	0,85	125	3,3
1	30	300	1,6	140	20	218,3	36,38	0,85	145	3,3
1	30	300	1,6	160	20	191,0	31,83	0,85	166	3,3
1	30	375	0,6	120	20	95,5	15,92	0,85	151	1,5
1	30	375	0,6	140	20	81,9	13,64	0,85	176	1,5
1	30	375	0,8	120	20	127,3	21,22	0,85	151	2,0
1	30	375	0,8	140	20	109,1	18,19	0,85	176	2,0
1	30	375	1	120	20	159,2	26,53	0,85	151	2,5
1	30	375	1	140	20	136,4	22,74	0,85	176	2,5
1	30	375	1,6	120	20	254,6	42,44	0,85	151	4,0
1	30	375	1,6	140	20	218,3	36,38	0,85	176	4,0
1	30	450	0,6	120	20	95,5	15,92	0,85	177	1,8
1	30	450	0,8	120	20	127,3	21,22	0,85	177	2,4
1	30	450	1	120	20	159,2	26,53	0,85	177	2,9
1	30	450	1,6	120	20	254,6	42,44	0,85	177	4,7
2	30	450	0,6	120	20	191,0	31,83	0,85	99	2,0
2	30	450	0,6	140	20	163,7	27,28	0,85	115	2,0
2	30	450	0,6	160	20	143,2	23,87	0,85	132	2,0
2	30	450	0,6	200*	20	114,6	19,10	0,85	164	2,0
2	30	450	0,8	120	20	254,6	42,44	0,85	99	2,6
2	30	450	0,8	140	20	218,3	36,38	0,85	115	2,6
2	30	450	0,8	160	20	191,0	31,83	0,85	132	2,6
2	30	450	0,8	200*	20	152,8	25,46	0,85	164	2,6
2	30	450	1	120	20	318,3	53,05	0,85	99	3,3
2	30	450	1	140	20	272,8	45,47	0,85	115	3,3
2	30	450	1	160	20	238,7	39,79	0,85	132	3,3
2	30	450	1	200*	20	191,0	31,83	0,85	164	3,3
2	30	450	1,6	120	20	509,3	84,88	0,85	99	5,3
2	30	450	1,6	140	20	436,5	72,76	0,85	115	5,3
2	30	450	1,6	160	20	382,0	63,66	0,85	132	5,3
2	30	450	1,6	200*	20	305,6	50,93	0,85	164	5,3
2	30	630	0,6	120	20	191,0	31,83	0,85	130	2,6
2	30	630	0,6	140	20	163,7	27,28	0,85	151	2,6
2	30	630	0,6	160	20	143,2	23,87	0,85	173	2,6
2	30	630	0,8	120	20	254,6	42,44	0,85	130	3,5
2	30	630	0,8	140	20	218,3	36,38	0,85	151	3,5
2	30	630	0,8	160	20	191,0	31,83	0,85	173	3,5
2	30	630	1	120	20	318,3	53,05	0,85	130	4,3
2	30	630	1	140	20	272,8	45,47	0,85	151	4,3
2	30	630	1	160	20	238,7	39,79	0,85	173	4,3
2	30	630	1,6	120	20	509,3	84,88	0,85	130	6,9
2	30	630	1,6	140	20	436,5	72,76	0,85	151	6,9
2	30	630	1,6	160	20	382,0	63,66	0,85	173	6,9
2	30	750	0,6	120	20	191,0	31,83	0,85	151	3,0
2	30	750	0,6	140	20	163,7	27,28	0,85	176	3,0
2	30	750	0,8	120	20	254,6	42,44	0,85	151	4,0
2	30	750	0,8	140	20	218,3	36,38	0,85	176	4,0



Tiro <i>Roping Factor</i>	Peso funi max <i>Max Ropes Weight [kg]</i>	Portata <i>Duty Load [kg]</i>	Velocità cabina <i>Cabin Speed [m/s]</i>	Ø Puleggia <i>Sheave Diameter [mm]</i>	Poli <i>Poles</i>	Velocità <i>Speed [rpm]</i>	Frequenza <i>Frequency [Hz]</i>	Efficienza vano <i>Shaft Efficiency</i>	Coppia <i>Torque [Nm]</i>	Potenza in uscita <i>Power Output [kW]</i>
	(1)			(2) (3)				(4)		
2	30	750	1	120	20	318,3	53,05	0,85	151	5,0
2	30	750	1	140	20	272,8	45,47	0,85	176	5,0
2	30	750	1,6	120	20	509,3	84,88	0,85	151	8,0
2	30	750	1,6	140	20	436,5	72,76	0,85	176	8,0
2	30	800	0,6	120	20	191,0	31,83	0,85	159	3,2
2	30	800	0,8	120	20	254,6	42,44	0,85	159	4,2
2	30	800	1	120	20	318,3	53,05	0,85	159	5,3
2	30	800	1,6	120	20	509,3	84,88	0,85	159	8,5

C_Max [Nm] = 180**G-180 T4•C4 - NOTES** * Sheave diameter available only for G-180 T4.**Brake Type:** DG01 - Standard 205 V DC - Other voltages on request.**Static Load:** G-180 T4: 2350 kg with traction sheave width 75mm - 2000 kg with traction sheave width 105mm.
G-180 C4: 2000 kg.**Encoder Type:** Absolute encoder with EnDat Interface or Incremental sin/cos, both with 2048 ppr;**Note 1:** For higher ropes weight, please consult sales/technical services of Alberto Sassi SpA.**Note 2:** Details on ropes/grooves provided upon lift data.**Note 3:** Suitable for steel core ropes or also for plastic coated ropes.**Note 4:** Shaft efficiency includes divertor pulleys efficiency by considering: 3 divertors for roping 2:1. Values are supposed.**Note 5:** Max 90 sts/h - 20% ED without fans.
Max 180 sts/h - 40% ED with fans activated by thermocontacts inside motor.**Note 6:** DGXY certified brake against Overspeed in upward direction and as UCM (EN 81-20:2014, EN 81-50:2014) with reference to Lift Directive 2014/33/EU.**Note 7:** G-180 T4: Traction sheave width 75 mm or 105 mm.
G-180 C4: Traction sheave width 80 mm.**Note 8:** G-180 T4: Weight 110 kg.
G-180 C4: Weight 124 kg.*The Alberto Sassi SpA reserves the rights to change data and features without previous notice.*



Tiro <i>Roping Factor</i>	Peso funi max <i>Max Ropes Weight [kg]</i>	Portata <i>Duty Load [kg]</i>	Velocità cabina <i>Cabin Speed [m/s]</i>	Ø Puleggia <i>Sheave Diameter [mm]</i>	Poli <i>Poles</i>	Velocità <i>Speed [rpm]</i>	Frequenza <i>Frequency [Hz]</i>	Efficienza vano <i>Shaft Efficiency</i>	Coppia <i>Torque [Nm]</i>	Potenza in uscita <i>Power Output [kW]</i>
	(1)			(2) (3)				(4)		
1	30	375	0,6	120	20	95,5	15,92	0,85	151	1,5
1	30	375	0,6	140	20	81,9	13,64	0,85	176	1,5
1	30	375	0,6	160	20	71,6	11,94	0,85	201	1,5
1	30	375	0,8	120	20	127,3	21,22	0,85	151	2,0
1	30	375	0,8	140	20	109,1	18,19	0,85	176	2,0
1	30	375	0,8	160	20	95,5	15,92	0,85	201	2,0
1	30	375	1	120	20	159,2	26,53	0,85	151	2,5
1	30	375	1	140	20	136,4	22,74	0,85	176	2,5
1	30	375	1	160	20	119,4	19,89	0,85	201	2,5
1	30	375	1,6	120	20	254,6	42,44	0,85	151	4,0
1	30	375	1,6	140	20	218,3	36,38	0,85	176	4,0
1	30	375	1,6	160	20	191,0	31,83	0,85	201	4,0
1	30	450	0,6	120	20	95,5	15,92	0,85	177	1,8
1	30	450	0,6	140	20	81,9	13,64	0,85	206	1,8
1	30	450	0,8	120	20	127,3	21,22	0,85	177	2,4
1	30	450	0,8	140	20	109,1	18,19	0,85	206	2,4
1	30	450	1	120	20	159,2	26,53	0,85	177	2,9
1	30	450	1	140	20	136,4	22,74	0,85	206	2,9
1	30	450	1,6	120	20	254,6	42,44	0,85	177	4,7
1	30	450	1,6	140	20	218,3	36,38	0,85	206	4,7
2	30	630	0,6	120	20	191,0	31,83	0,85	130	2,6
2	30	630	0,6	140	20	163,7	27,28	0,85	151	2,6
2	30	630	0,6	160	20	143,2	23,87	0,85	173	2,6
2	30	630	0,6	200	20	114,6	19,10	0,85	216	2,6
2	30	630	0,8	120	20	254,6	42,44	0,85	130	3,5
2	30	630	0,8	140	20	218,3	36,38	0,85	151	3,5
2	30	630	0,8	160	20	191,0	31,83	0,85	173	3,5
2	30	630	0,8	200	20	152,8	25,46	0,85	216	3,5
2	30	630	1	120	20	318,3	53,05	0,85	130	4,3
2	30	630	1	140	20	272,8	45,47	0,85	151	4,3
2	30	630	1	160	20	238,7	39,79	0,85	173	4,3
2	30	630	1	200	20	191,0	31,83	0,85	216	4,3
2	30	630	1,6	120	20	509,3	84,88	0,85	130	6,9
2	30	630	1,6	140	20	436,5	72,76	0,85	151	6,9
2	30	630	1,6	160	20	382,0	63,66	0,85	173	6,9
2	30	630	1,6	200	20	305,6	50,93	0,85	216	6,9
2	30	800	0,6	120	20	191,0	31,83	0,85	159	3,2
2	30	800	0,6	140	20	163,7	27,28	0,85	186	3,2
2	30	800	0,6	160	20	143,2	23,87	0,85	212	3,2
2	30	800	0,8	120	20	254,6	42,44	0,85	159	4,2
2	30	800	0,8	140	20	218,3	36,38	0,85	186	4,2
2	30	800	0,8	160	20	191,0	31,83	0,85	212	4,2



Tiro <i>Roping Factor</i>	Peso funi max <i>Max Ropes Weight [kg]</i>	Portata <i>Duty Load [kg]</i>	Velocità cabina <i>Cabin Speed [m/s]</i>	Ø Puleggia <i>Sheave Diameter [mm]</i>	Poli <i>Poles</i>	Velocità <i>Speed [rpm]</i>	Frequenza <i>Frequency [Hz]</i>	Efficienza vano <i>Shaft Efficiency</i>	Coppia <i>Torque [Nm]</i>	Potenza in uscita <i>Power Output [kW]</i>
	(1)			(2) (3)				(4)		
2	30	800	1	120	20	318,3	53,05	0,85	159	5,3
2	30	800	1	140	20	272,8	45,47	0,85	186	5,3
2	30	800	1	160	20	238,7	39,79	0,85	212	5,3
2	30	800	1,6	120	20	509,3	84,88	0,85	159	8,5
2	30	800	1,6	140	20	436,5	72,76	0,85	186	8,5
2	30	800	1,6	160	20	382,0	63,66	0,85	212	8,5
2	30	1000	0,6	120	20	191,0	31,83	0,85	194	3,9
2	30	1000	0,8	120	20	254,6	42,44	0,85	194	5,2
2	30	1000	1	120	20	318,3	53,05	0,85	194	6,5
2	30	1000	1,6	120	20	509,3	84,88	0,85	194	10,3

C_Max [Nm] = 218**G-180 T5 - NOTES****Brake Type:** DG01 - Standard 205 V DC - Other voltages on request.**Static Load:** 2350 kg with traction sheave width 75mm - 2000 kg with traction sheave width 105mm.**Encoder Type:** Absolute encoder with EnDat Interface or Incremental sin/cos, both with 2048 ppr;**Note 1:** For higher ropes weight, please consult sales/technical services of Alberto Sassi SpA.**Note 2:** Details on ropes/grooves provided upon lift data.**Note 3:** Suitable for steel core ropes or also for plastic coated ropes.**Note 4:** Shaft efficiency includes divertor pulleys efficiency by considering: 3 divertors for roping 2:1. Values are supposed.**Note 5:** Max 90 sts/h - 20% ED without fans.
Max 180 sts/h - 40% ED with fans activated by thermocontacts inside motor.**Note 6:** DGXY certified brake against Overspeed in upward direction and as UCM (EN 81-1:1998+A3:2009, EN 81-20:2014, EN 81-50:2014) with reference to Lift Directive 2014/33/EU.**Note 7:** Traction sheave width 75 mm or 105 mm.**Note 8:** Weight 116 kg.*The Alberto Sassi SpA reserves the rights to change data and features without previous notice.*



Tiro	Peso funi max	Portata	Velocità cabina	Ø Puleggia	Poli	Velocità	Frequenza	Efficienza vano	Coppia	Potenza in uscita
Roping Factor	Max Ropes Weight [kg]	Duty Load [kg]	Cabin Speed [m/s]	Sheave Diameter [mm]	Poles	Speed [rpm]	Frequency [Hz]	Shaft Efficiency	Torque [Nm]	Power Output [kW]
	(1)			(2) (3)				(4)		
1	30	375	0,6	120	20	95,5	15,92	0,85	151	1,5
1	30	375	0,6	140	20	81,9	13,64	0,85	176	1,5
1	30	375	0,6	160	20	71,6	11,94	0,85	201	1,5
1	30	375	0,6	200	20	57,3	9,55	0,85	251	1,5
1	30	375	0,8	120	20	127,3	21,22	0,85	151	2,0
1	30	375	0,8	140	20	109,1	18,19	0,85	176	2,0
1	30	375	0,8	160	20	95,5	15,92	0,85	201	2,0
1	30	375	0,8	200	20	76,4	12,73	0,85	251	2,0
1	30	375	1	120	20	159,2	26,53	0,85	151	2,5
1	30	375	1	140	20	136,4	22,74	0,85	176	2,5
1	30	375	1	160	20	119,4	19,89	0,85	201	2,5
1	30	375	1	200	20	95,5	15,92	0,85	251	2,5
1	30	375	1,6	120	20	254,6	42,44	0,85	151	4,0
1	30	375	1,6	140	20	218,3	36,38	0,85	176	4,0
1	30	375	1,6	160	20	191,0	31,83	0,85	201	4,0
1	30	375	1,6	200	20	152,8	25,46	0,85	251	4,0
1	30	450	0,6	120	20	95,5	15,92	0,85	177	1,8
1	30	450	0,6	140	20	81,9	13,64	0,85	206	1,8
1	30	450	0,6	160	20	71,6	11,94	0,85	235	1,8
1	30	450	0,8	120	20	127,3	21,22	0,85	177	2,4
1	30	450	0,8	140	20	109,1	18,19	0,85	206	2,4
1	30	450	0,8	160	20	95,5	15,92	0,85	235	2,4
1	30	450	1	120	20	159,2	26,53	0,85	177	2,9
1	30	450	1	140	20	136,4	22,74	0,85	206	2,9
1	30	450	1	160	20	119,4	19,89	0,85	235	2,9
1	30	450	1,6	120	20	254,6	42,44	0,85	177	4,7
1	30	450	1,6	140	20	218,3	36,38	0,85	206	4,7
1	30	450	1,6	160	20	191,0	31,83	0,85	235	4,7
1	30	600	0,6	120	20	95,5	15,92	0,85	229	2,3
1	30	600	0,6	140	20	81,9	13,64	0,85	267	2,3
1	30	600	0,8	120	20	127,3	21,22	0,85	229	3,0
1	30	600	0,8	140	20	109,1	18,19	0,85	267	3,0
1	30	600	1	120	20	159,2	26,53	0,85	229	3,8
1	30	600	1	140	20	136,4	22,74	0,85	267	3,8
1	30	600	1,6	120	20	254,6	42,44	0,85	229	6,1
1	30	600	1,6	140	20	218,3	36,38	0,85	267	6,1
1	30	630	0,6	120	20	95,5	15,92	0,85	239	2,4
1	30	630	0,8	120	20	127,3	21,22	0,85	239	3,2
1	30	630	1	120	20	159,2	26,53	0,85	239	4,0
1	30	630	1,6	120	20	254,6	42,44	0,85	239	6,4
2	30	630	0,6	120	20	191,0	31,83	0,85	130	2,6
2	30	630	0,6	140	20	163,7	27,28	0,85	151	2,6
2	30	630	0,6	160	20	143,2	23,87	0,85	173	2,6
2	30	630	0,6	200	20	114,6	19,10	0,85	216	2,6
2	30	630	0,8	120	20	254,6	42,44	0,85	130	3,5
2	30	630	0,8	140	20	218,3	36,38	0,85	151	3,5
2	30	630	0,8	160	20	191,0	31,83	0,85	173	3,5
2	30	630	0,8	200	20	152,8	25,46	0,85	216	3,5
2	30	630	1	120	20	318,3	53,05	0,85	130	4,3
2	30	630	1	140	20	272,8	45,47	0,85	151	4,3
2	30	630	1	160	20	238,7	39,79	0,85	173	4,3
2	30	630	1	200	20	191,0	31,83	0,85	216	4,3
2	30	630	1,6	120	20	509,3	84,88	0,85	130	6,9
2	30	630	1,6	140	20	436,5	72,76	0,85	151	6,9
2	30	630	1,6	160	20	382,0	63,66	0,85	173	6,9
2	30	630	1,6	200	20	305,6	50,93	0,85	216	6,9
2	30	800	0,6	120	20	191,0	31,83	0,85	159	3,2
2	30	800	0,6	140	20	163,7	27,28	0,85	186	3,2



Tiro	Peso funi max	Portata	Velocità cabina	Ø Puleggia	Poli	Velocità	Frequenza	Efficienza vano	Coppia	Potenza in uscita
Roping Factor	Max Ropes Weight [kg]	Duty Load [kg]	Cabin Speed [m/s]	Sheave Diameter [mm]	Poles	Speed [rpm]	Frequency [Hz]	Shaft Efficiency	Torque [Nm]	Power Output [kW]
	(1)			(2) (3)				(4)		
2	30	800	0,6	160	20	143,2	23,87	0,85	212	3,2
2	30	800	0,6	200	20	114,6	19,10	0,85	265	3,2
2	30	800	0,8	120	20	254,6	42,44	0,85	159	4,2
2	30	800	0,8	140	20	218,3	36,38	0,85	186	4,2
2	30	800	0,8	160	20	191,0	31,83	0,85	212	4,2
2	30	800	0,8	200	20	152,8	25,46	0,85	265	4,2
2	30	800	1	120	20	318,3	53,05	0,85	159	5,3
2	30	800	1	140	20	272,8	45,47	0,85	186	5,3
2	30	800	1	160	20	238,7	39,79	0,85	212	5,3
2	30	800	1	200	20	191,0	31,83	0,85	265	5,3
2	30	800	1,6	120	20	509,3	84,88	0,85	159	8,5
2	30	800	1,6	140	20	436,5	72,76	0,85	186	8,5
2	30	800	1,6	160	20	382,0	63,66	0,85	212	8,5
2	30	800	1,6	200	20	305,6	50,93	0,85	265	8,5
2	30	1000	0,6	120	20	191,0	31,83	0,85	194	3,9
2	30	1000	0,6	140	20	163,7	27,28	0,85	226	3,9
2	30	1000	0,6	160	20	143,2	23,87	0,85	259	3,9
2	30	1000	0,8	120	20	254,6	42,44	0,85	194	5,2
2	30	1000	0,8	140	20	218,3	36,38	0,85	226	5,2
2	30	1000	0,8	160	20	191,0	31,83	0,85	259	5,2
2	30	1000	1	120	20	318,3	53,05	0,85	194	6,5
2	30	1000	1	140	20	272,8	45,47	0,85	226	6,5
2	30	1000	1	160	20	238,7	39,79	0,85	259	6,5
2	30	1000	1,6	120	20	509,3	84,88	0,85	194	10,3
2	30	1000	1,6	140	20	436,5	72,76	0,85	226	10,3
2	30	1000	1,6	160	20	382,0	63,66	0,85	259	10,3
2	30	1050	0,6	120	20	191,0	31,83	0,85	203	4,1
2	30	1050	0,6	140	20	163,7	27,28	0,85	236	4,1
2	30	1050	0,8	120	20	254,6	42,44	0,85	203	5,4
2	30	1050	0,8	140	20	218,3	36,38	0,85	236	5,4
2	30	1050	1	120	20	318,3	53,05	0,85	203	6,8
2	30	1050	1	140	20	272,8	45,47	0,85	236	6,8
2	30	1050	1,6	120	20	509,3	84,88	0,85	203	10,8
2	30	1050	1,6	140	20	436,5	72,76	0,85	236	10,8

C_Max [Nm] = 270**G-180 T6 - NOTES****Brake Type:** DG02 - Standard 205 V DC - Other voltages on request.**Static Load:** 2350 kg with traction sheave width 75 mm - 2000 kg with traction sheave width 105mm.**Encoder Type:** Absolute encoder with EnDat Interface or Incremental sin/cos, both with 2048 ppr;**Note 1:** For higher ropes weight, please consult sales/technical services of Alberto Sassi SpA.**Note 2:** Details on ropes/grooves provided upon lift data.**Note 3:** Suitable for steel core ropes or also for plastic coated ropes.**Note 4:** Shaft efficiency includes divertor pulleys efficiency by considering: 3 divertors for roping 2:1. Values are supposed.**Note 5:** Max 90 sts/h - 20% ED without fans.
Max 180 sts/h - 40% ED with fans activated by thermocontacts inside motor.**Note 6:** DGXY certified brake against Overspeed in upward direction and as UCM (EN 81-20:2014, EN 81-50:2014) with reference to Lift Directive 2014/33/EU.**Note 7:** Traction sheave width 75 mm or 105 mm.**Note 8:** Weight 128 kg.*The Alberto Sassi SpA reserves the rights to change data and features without previous notice.*

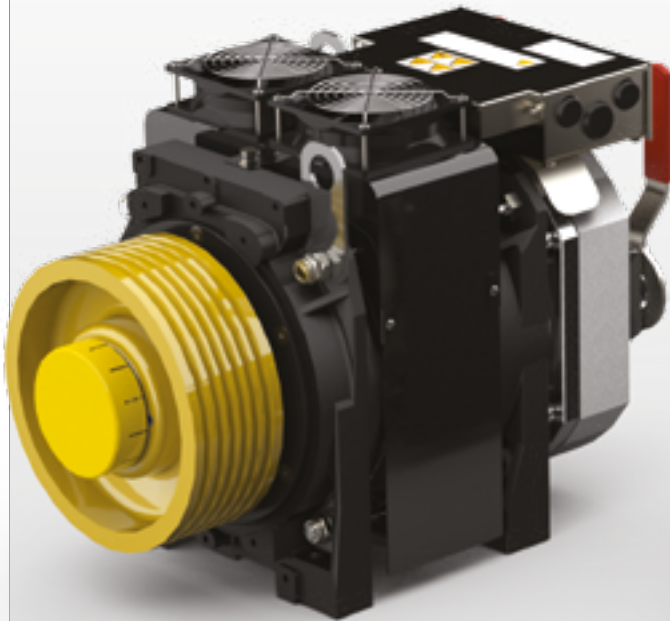

G-200 T1
G-200 TS

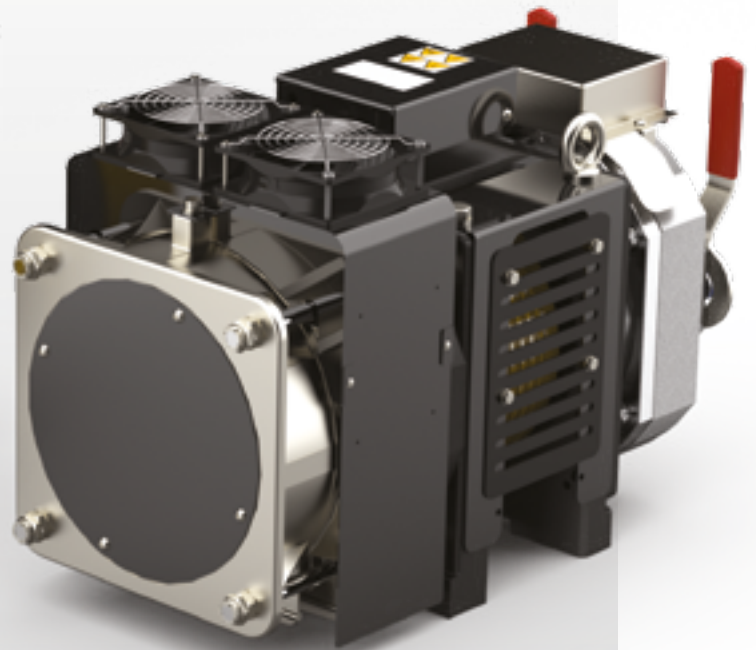

G-200 TC

G-200 T1•TS•TC

	Senza ventole di raffreddamento <i>Without cooling fans</i>						Con ventole di raffreddamento <i>With cooling fans</i>				
Carico statico / <i>Static load</i> [kg]	2500										
Coppia / <i>Rated torque</i>	190 Nm						230 Nm				
Peso / <i>Weight</i> [kg]	122 kg						134 kg				
Portata / <i>Duty load</i> [kg]	300	320	400	450	480	630	320	400	630	800	
Tiro / <i>Suspension</i>	1/1	2/1	2/1	2/1	2/1	2/1	1/1		2/1		
Gamma velocità cabina <i>Range of cabin speed</i> [m/s]	0,63 ÷ 1,60					0,63 ÷ 1,00	0,63 ÷ 1,60			0,63 ÷ 1,00	
Gamma Ø pulegge <i>Range sheave Ø</i> [mm]	120 - 140 160	120 → 240		120 → 210		120 - 140 160	160 - 210	160	160 - 210		160
Max combinazione funi <i>Max ropes combination</i>	n°8 Ø 6 - 6,5 - 6,7mm										

16 Poles



G-200 T1 Senza ventilatori / Without cooling fans

G-200 T1-TS Con ventilatori / With cooling fans

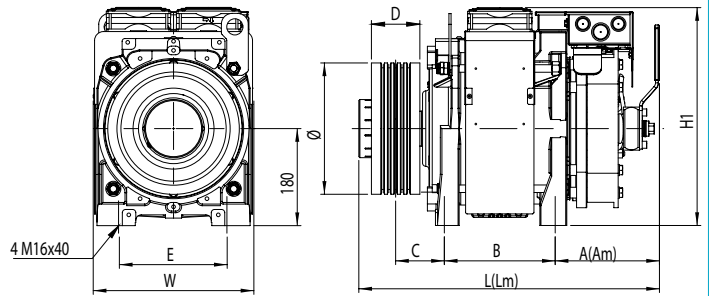
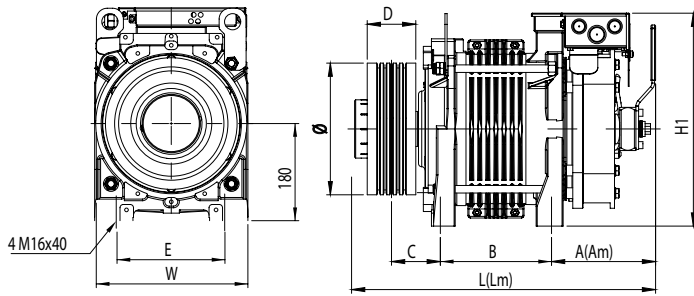

G-200 T1 Senza ventilatori / Without cooling fans

A	L	Am	Lm	B	C	E	W	H1	D	Ø
147	512	192	557	206	90.5	200	284	395	90	120 - 140 - 160 - 210 - 240
	520		565		105.5				120	120 - 140 - 160
	520		565		95.5				120	210 - 240 - 320

G-200 - T1-TS Con ventilatori / With cooling fans

A	L	Am	Lm	B	C	E	W	H1	D	Ø
147	512	192	557	206	90.5	200	296	405	90	120 - 140 - 160 - 210 - 240
	520		565		105.5				120	120 - 140 - 160
	520		565		95.5				120	210 - 240 - 320

G-200 TC Senza ventilatori / Without cooling fans

G-200 TC Con ventilatori / With cooling fans

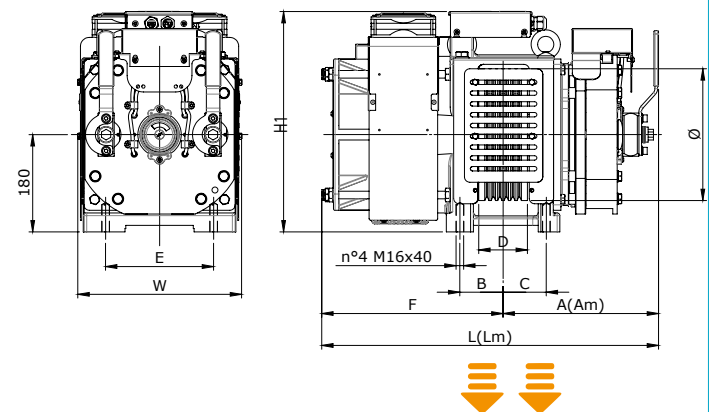
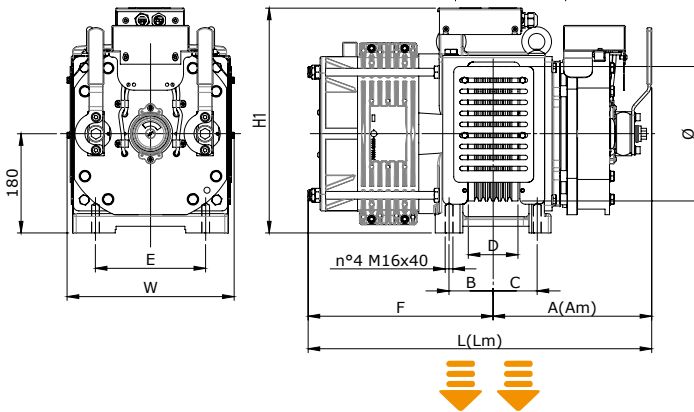

Unica direzione per l'uscita delle funi / Sole direction for ropes' exit

G-200 TC Senza ventilatori / Without cooling fans

A	L	Am	Lm	B	C	E	F	W	H1	D	Ø
240	582	285	627	80	80	200	342	290	400	90	120 - 140 - 160 - 210 - 240
				87.5	72.5					105	120 - 140 - 160

G-200 TC Con ventilatori / With cooling fans

A	L	Am	Lm	B	C	E	F	W	H1	D	Ø
240	582	285	627	80	80	200	342	296	405	90	120 - 140 - 160 - 210 - 240
				87.5	72.5					105	120 - 140 - 160

G-200 TC: encoder mounted on brake side

- **Am** | **Lm**
- = quote con manovra apertura a mano
- = dimensions with lever for hand release
- = Abmessungen mit Hebel für Nothandlüftung



G-200 T1 IP66 Senza ventilatori / Without cooling fans *



* configurazione solo senza ventilatore né leve del freno / only configuration without neither fan nor brake levers.

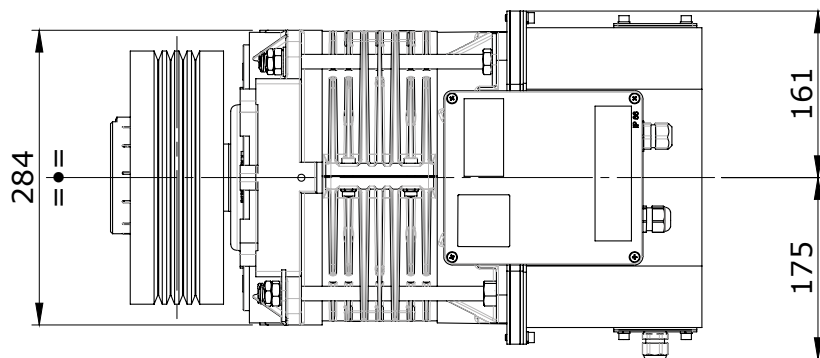
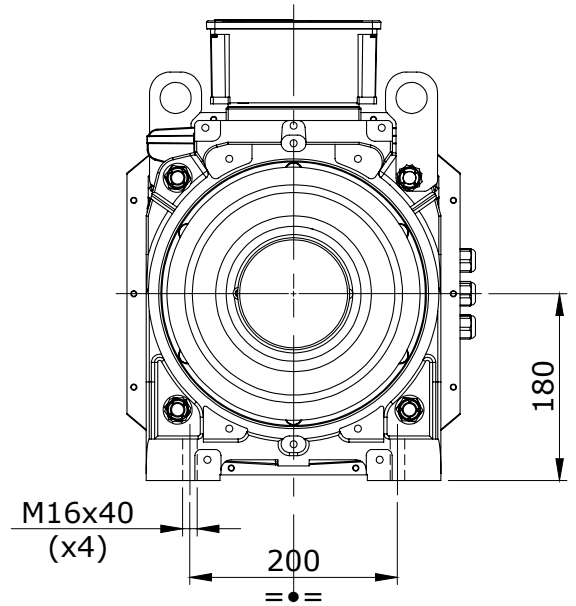
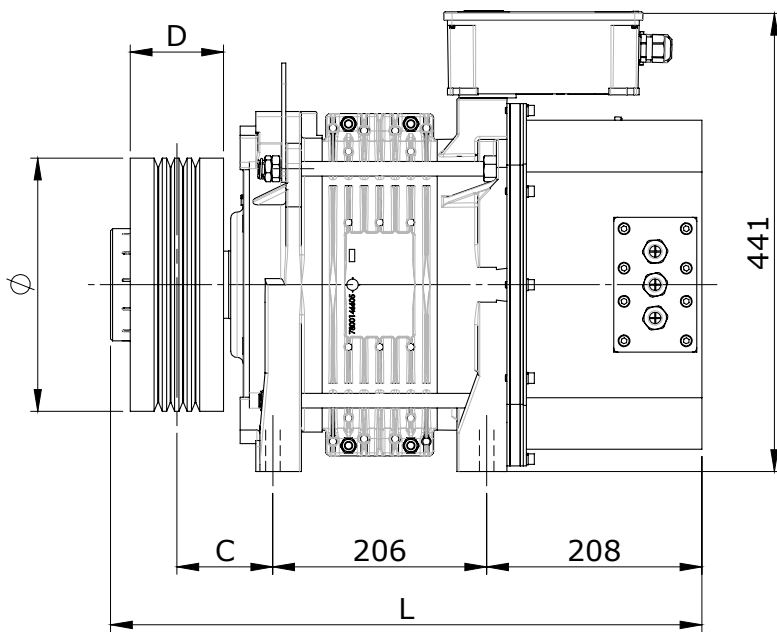

G-200 T1			
L	C	D	Ø
572	90.5	90	120 - 140 - 160 - 210 - 240
580	105.5	120	120 - 140 - 160
580	95.5	120	210 - 240 - 320



Tiro	Peso funi max	Portata	Velocità cabina	Ø Puleggia	Poli	Velocità	Frequenza	Efficienza vano	Coppia	Potenza in uscita
Roping Factor	Max Ropes Weight [kg]	Duty Load [kg]	Cabin Speed [m/s]	Sheave Diameter [mm]	Poles	Speed [rpm]	Frequency [Hz]	Shaft Efficiency	Torque [Nm]	Power Output [kW]
	(1)			(2) (3)				(4)		
1	30	180	0,63	120	16	100,3	13,37	0,85	83	0,9
1	30	180	0,63	140	16	85,9	11,46	0,85	97	0,9
1	30	180	0,63	160	16	75,2	10,03	0,85	111	0,9
1	30	180	0,63	210	16	57,3	7,64	0,85	145	0,9
1	30	180	0,63	240	16	50,1	6,68	0,85	166	0,9
1	30	180	0,8	120	16	127,3	16,98	0,85	83	1,1
1	30	180	0,8	140	16	109,1	14,55	0,85	97	1,1
1	30	180	0,8	160	16	95,5	12,73	0,85	111	1,1
1	30	180	0,8	210	16	72,8	9,70	0,85	145	1,1
1	30	180	0,8	240	16	63,7	8,49	0,85	166	1,1
1	30	180	1	120	16	159,2	21,22	0,85	83	1,4
1	30	180	1	140	16	136,4	18,19	0,85	97	1,4
1	30	180	1	160	16	119,4	15,92	0,85	111	1,4
1	30	180	1	210	16	90,9	12,13	0,85	145	1,4
1	30	180	1	240	16	79,6	10,61	0,85	166	1,4
1	30	180	1,6	120	16	254,6	33,95	0,85	83	2,2
1	30	180	1,6	140	16	218,3	29,10	0,85	97	2,2
1	30	180	1,6	160	16	191,0	25,46	0,85	111	2,2
1	30	180	1,6	210	16	145,5	19,40	0,85	145	2,2
1	30	180	1,6	240	16	127,3	16,98	0,85	166	2,2
1	30	225	0,63	120	16	100,3	13,37	0,85	99	1,0
1	30	225	0,63	140	16	85,9	11,46	0,85	115	1,0
1	30	225	0,63	160	16	75,2	10,03	0,85	132	1,0
1	30	225	0,63	210	16	57,3	7,64	0,85	173	1,0
1	30	225	0,8	120	16	127,3	16,98	0,85	99	1,3
1	30	225	0,8	140	16	109,1	14,55	0,85	115	1,3
1	30	225	0,8	160	16	95,5	12,73	0,85	132	1,3
1	30	225	0,8	210	16	72,8	9,70	0,85	173	1,3
1	30	225	1	120	16	159,2	21,22	0,85	99	1,6
1	30	225	1	140	16	136,4	18,19	0,85	115	1,6
1	30	225	1	160	16	119,4	15,92	0,85	132	1,6
1	30	225	1	210	16	90,9	12,13	0,85	173	1,6
1	30	225	1,6	120	16	254,6	33,95	0,85	99	2,6
1	30	225	1,6	140	16	218,3	29,10	0,85	115	2,6
1	30	225	1,6	160	16	191,0	25,46	0,85	132	2,6
1	30	225	1,6	210	16	145,5	19,40	0,85	173	2,6
1	30	300	0,63	120	16	100,3	13,37	0,85	125	1,3
1	30	300	0,63	140	16	85,9	11,46	0,85	145	1,3
1	30	300	0,63	160	16	75,2	10,03	0,85	166	1,3
1	30	300	0,8	120	16	127,3	16,98	0,85	125	1,7
1	30	300	0,8	140	16	109,1	14,55	0,85	145	1,7
1	30	300	0,8	160	16	95,5	12,73	0,85	166	1,7
1	30	300	1	120	16	159,2	21,22	0,85	125	2,1
1	30	300	1	140	16	136,4	18,19	0,85	145	2,1
1	30	300	1	160	16	119,4	15,92	0,85	166	2,1
1	30	300	1,6	120	16	254,6	33,95	0,85	125	3,3
1	30	300	1,6	140	16	218,3	29,10	0,85	145	3,3
1	30	300	1,6	160	16	191,0	25,46	0,85	166	3,3
1	30	375	0,63	120	16	100,3	13,37	0,85	151	1,6
1	30	375	0,63	140	16	85,9	11,46	0,85	176	1,6
1	30	375	0,8	120	16	127,3	16,98	0,85	151	2,0
1	30	375	0,8	140	16	109,1	14,55	0,85	176	2,0
1	30	375	1	120	16	159,2	21,22	0,85	151	2,5
1	30	375	1	140	16	136,4	18,19	0,85	176	2,5
1	30	375	1,6	120	16	254,6	33,95	0,85	151	4,0
1	30	375	1,6	140	16	218,3	29,10	0,85	176	4,0
1	30	400	0,63	120	16	100,3	13,37	0,85	159	1,7
1	30	400	0,63	140	16	85,9	11,46	0,85	186	1,7
1	30	400	0,8	120	16	127,3	16,98	0,85	159	2,1



Tiro	Peso funi max	Portata	Velocità cabina	Ø Puleggia	Poli	Velocità	Frequenza	Efficienza vano	Coppia	Potenza in uscita
Roping Factor	Max Ropes Weight [kg]	Duty Load [kg]	Cabin Speed [m/s]	Sheave Diameter [mm]	Poles	Speed [rpm]	Frequency [Hz]	Shaft Efficiency	Torque [Nm]	Power Output [kW]
	(1)			(2) (3)				(4)		
1	30	400	0,8	140	16	109,1	14,55	0,85	186	2,1
1	30	400	1	120	16	159,2	21,22	0,85	159	2,7
1	30	400	1	140	16	136,4	18,19	0,85	186	2,7
1	30	400	1,6	120	16	254,6	33,95	0,85	159	4,2
1	30	400	1,6	140	16	218,3	29,10	0,85	186	4,2
1	30	450	0,63	120	16	100,3	13,37	0,85	177	1,9
1	30	450	0,8	120	16	127,3	16,98	0,85	177	2,4
1	30	450	1	120	16	159,2	21,22	0,85	177	2,9
1	30	450	1,6	120	16	254,6	33,95	0,85	177	4,7
1	30	480	0,63	120	16	100,3	13,37	0,85	187	2,0
1	30	480	0,8	120	16	127,3	16,98	0,85	187	2,5
1	30	480	1	120	16	159,2	21,22	0,85	187	3,1
1	30	480	1,6	120	16	254,6	33,95	0,85	187	5,0
2	30	400	0,63	120	16	200,5	26,74	0,85	90	1,9
2	30	400	0,63	140	16	171,9	22,92	0,85	105	1,9
2	30	400	0,63	160	16	150,4	20,05	0,85	120	1,9
2	30	400	0,63	210	16	114,6	15,28	0,85	158	1,9
2	30	400	0,63	240	16	100,3	13,37	0,85	180	1,9
2	30	400	0,8	120	16	254,6	33,95	0,85	90	2,4
2	30	400	0,8	140	16	218,3	29,10	0,85	105	2,4
2	30	400	0,8	160	16	191,0	25,46	0,85	120	2,4
2	30	400	0,8	210	16	145,5	19,40	0,85	158	2,4
2	30	400	0,8	240	16	127,3	16,98	0,85	180	2,4
2	30	400	1	120	16	318,3	42,44	0,85	90	3,0
2	30	400	1	140	16	272,8	36,38	0,85	105	3,0
2	30	400	1	160	16	238,7	31,83	0,85	120	3,0
2	30	400	1	210	16	181,9	24,25	0,85	158	3,0
2	30	400	1	240	16	159,2	21,22	0,85	180	3,0
2	30	400	1,6	210	16	291,0	38,80	0,85	158	4,8
2	30	400	1,6	240	16	254,6	33,95	0,85	180	4,8
2	30	450	0,63	120	16	200,5	26,74	0,85	99	2,1
2	30	450	0,63	140	16	171,9	22,92	0,85	115	2,1
2	30	450	0,63	160	16	150,4	20,05	0,85	132	2,1
2	30	450	0,63	210	16	114,6	15,28	0,85	173	2,1
2	30	450	0,8	120	16	254,6	33,95	0,85	99	2,6
2	30	450	0,8	140	16	218,3	29,10	0,85	115	2,6
2	30	450	0,8	160	16	191,0	25,46	0,85	132	2,6
2	30	450	0,8	210	16	145,5	19,40	0,85	173	2,6
2	30	450	1	120	16	318,3	42,44	0,85	99	3,3
2	30	450	1	140	16	272,8	36,38	0,85	115	3,3
2	30	450	1	160	16	238,7	31,83	0,85	132	3,3
2	30	450	1	210	16	181,9	24,25	0,85	173	3,3
2	30	450	1,6	210	16	291,0	38,80	0,85	173	5,3
2	30	480	0,63	120	16	200,5	26,74	0,85	104	2,2
2	30	480	0,63	140	16	171,9	22,92	0,85	121	2,2
2	30	480	0,63	160	16	150,4	20,05	0,85	138	2,2
2	30	480	0,63	210	16	114,6	15,28	0,85	182	2,2
2	30	480	0,8	120	16	254,6	33,95	0,85	104	2,8
2	30	480	0,8	140	16	218,3	29,10	0,85	121	2,8
2	30	480	0,8	160	16	191,0	25,46	0,85	138	2,8
2	30	480	0,8	210	16	145,5	19,40	0,85	182	2,8
2	30	480	1	120	16	318,3	42,44	0,85	104	3,5
2	30	480	1	140	16	272,8	36,38	0,85	121	3,5
2	30	480	1	160	16	238,7	31,83	0,85	138	3,5
2	30	480	1	210	16	181,9	24,25	0,85	182	3,5
2	30	480	1,6	210	16	291,0	38,80	0,85	182	5,5
2	30	630	0,63	120	16	200,5	26,74	0,85	130	2,7
2	30	630	0,63	140	16	171,9	22,92	0,85	151	2,7
2	30	630	0,63	160	16	150,4	20,05	0,85	173	2,7



Tiro <i>Roping Factor</i>	Peso funi max <i>Max Ropes Weight [kg]</i>	Portata <i>Duty Load [kg]</i>	Velocità cabina <i>Cabin Speed [m/s]</i>	Ø Puleggia <i>Sheave Diameter [mm]</i>	Poli <i>Poles</i>	Velocità <i>Speed [rpm]</i>	Frequenza <i>Frequency [Hz]</i>	Efficienza vano <i>Shaft Efficiency</i>	Coppia <i>Torque [Nm]</i>	Potenza in uscita <i>Power Output [kW]</i>
	(1)			(2) (3)				(4)		
2	30	630	0,8	120	16	254,6	33,95	0,85	130	3,5
2	30	630	0,8	140	16	218,3	29,10	0,85	151	3,5
2	30	630	0,8	160	16	191,0	25,46	0,85	173	3,5
2	30	630	1	120	16	318,3	42,44	0,85	130	4,3
2	30	630	1	140	16	272,8	36,38	0,85	151	4,3
2	30	630	1	160	16	238,7	31,83	0,85	173	4,3
2	30	750	0,63	120	16	200,5	26,74	0,85	151	3,2
2	30	750	0,63	140	16	171,9	22,92	0,85	176	3,2
2	30	750	0,8	120	16	254,6	33,95	0,85	151	4,0
2	30	750	0,8	140	16	218,3	29,10	0,85	176	4,0
2	30	750	1	120	16	318,3	42,44	0,85	151	5,0
2	30	750	1	140	16	272,8	36,38	0,85	176	5,0
2	30	800	0,63	120	16	200,5	26,74	0,85	159	3,3
2	30	800	0,63	140	16	171,9	22,92	0,85	186	3,3
2	30	800	0,8	120	16	254,6	33,95	0,85	159	4,2
2	30	800	0,8	140	16	218,3	29,10	0,85	186	4,2
2	30	800	1	120	16	318,3	42,44	0,85	159	5,3
2	30	800	1	140	16	272,8	36,38	0,85	186	5,3

C_Max [Nm] = 190**G-200 T1•TC - NOTE****Brake Type:** DF11 - 205 V DC Standard. Other voltages on request.**Static Load:** 2500 kg.**Encoder Type:** Absolute encoder with EnDat Interface or Incremental sin/cos, both with 2048 ppr;**Note 1:** For higher ropes weight, please consult sales/technical services of Alberto Sassi SpA.**Note 2:** Details on ropes/grooves provided upon lift data.**Note 3:** Suitable for steel core ropes or also for plastic coated ropes.**Note 4:** Shaft efficiency includes divertor pulleys efficiency by considering: 3 divertors for roping 2:1. Values are suppose.**Note 5:** Max 240 sts/h - 40% ED without fans.

Max 240 sts/h - 50% ED with fans activated by thermocontacts inside motor.

Note 6: DFX certified brake against Overspeed in upward direction and as UCM (EN 81-20:2014, EN 81-50:2014) with reference to Lift Directive 2014/33/EU.**Note 7:** G-200 T1: Traction sheave width 90 mm. Available width 120 mm; traction sheave Ø320 only with width 120 mm.
G-200 TC: Traction sheave width 90 mm. Available width 105 mm for Ø120, Ø140, Ø160 mm.
Sheave Ø320 mm not available.*The Alberto Sassi SpA reserves the rights to change data and features without previous notice.*



Tiro	Peso funi max	Portata	Velocità cabina	Ø Puleggia	Poli	Velocità	Frequenza	Efficienza vano	Coppia	Potenza in uscita
Roping Factor	Max Ropes Weight [kg]	Duty Load [kg]	Cabin Speed [m/s]	Sheave Diameter [mm]	Poles	Speed [rpm]	Frequency [Hz]	Shaft Efficiency	Torque [Nm]	Power Output [kW]
	(1)			(2) (3)				(4)		
1	30	225	0,63	240	16	50,1	6,68	0,85	197	1,0
1	30	225	0,8	240	16	63,7	8,49	0,85	197	1,3
1	30	225	1	240	16	79,6	10,61	0,85	197	1,6
1	30	225	1,6	240	16	127,3	16,98	0,85	197	2,6
1	30	300	0,63	210	16	57,3	7,64	0,85	218	1,3
1	30	300	0,8	210	16	72,8	9,70	0,85	218	1,7
1	30	300	1	210	16	90,9	12,13	0,85	218	2,1
1	30	300	1,6	210	16	145,5	19,40	0,85	218	3,3
1	30	375	0,63	160	16	75,2	10,03	0,85	201	1,6
1	30	375	0,8	160	16	95,5	12,73	0,85	201	2,0
1	30	375	1	160	16	119,4	15,92	0,85	201	2,5
1	30	375	1,6	160	16	191,0	25,46	0,85	201	4,0
1	30	400	0,63	160	16	75,2	10,03	0,85	212	1,7
1	30	400	0,8	160	16	95,5	12,73	0,85	212	2,1
1	30	400	1	160	16	119,4	15,92	0,85	212	2,7
1	30	400	1,6	160	16	191,0	25,46	0,85	212	4,2
1	30	450	0,63	140	16	85,9	11,46	0,85	206	1,9
1	30	450	0,8	140	16	109,1	14,55	0,85	206	2,4
1	30	450	1	140	16	136,4	18,19	0,85	206	2,9
1	30	450	1,6	140	16	218,3	29,10	0,85	206	4,7
1	30	480	0,63	140	16	85,9	11,46	0,85	218	2,0
1	30	480	0,8	140	16	109,1	14,55	0,85	218	2,5
1	30	480	1	140	16	136,4	18,19	0,85	218	3,1
1	30	480	1,6	140	16	218,3	29,10	0,85	218	5,0
2	30	375	0,63	120	16	200,5	26,74	0,85	86	1,8
2	30	375	0,63	140	16	171,9	22,92	0,85	100	1,8
2	30	375	0,63	160	16	150,4	20,05	0,85	114	1,8
2	30	375	0,63	210	16	114,6	15,28	0,85	150	1,8
2	30	375	0,63	240	16	100,3	13,37	0,85	171	1,8
2	30	375	0,63	320*	16	75,2	10,03	0,85	229	1,8
2	30	375	0,8	120	16	254,6	33,95	0,85	86	2,3
2	30	375	0,8	140	16	218,3	29,10	0,85	100	2,3
2	30	375	0,8	160	16	191,0	25,46	0,85	114	2,3
2	30	375	0,8	210	16	145,5	19,40	0,85	150	2,3
2	30	375	0,8	240	16	127,3	16,98	0,85	171	2,3
2	30	375	0,8	320*	16	95,5	12,73	0,85	229	2,3
2	30	375	1	120	16	318,3	42,44	0,85	86	2,9
2	30	375	1	140	16	272,8	36,38	0,85	100	2,9
2	30	375	1	160	16	238,7	31,83	0,85	114	2,9
2	30	375	1	210	16	181,9	24,25	0,85	150	2,9
2	30	375	1	240	16	159,2	21,22	0,85	171	2,9
2	30	375	1	320*	16	119,4	15,92	0,85	229	2,9
2	30	375	1,6	210	16	291,0	38,80	0,85	150	4,6
2	30	375	1,6	240	16	254,6	33,95	0,85	171	4,6
2	30	375	1,6	320*	16	191,0	25,46	0,85	229	4,6
2	30	450	0,63	240	16	100,3	13,37	0,85	197	2,1
2	30	450	0,8	240	16	127,3	16,98	0,85	197	2,6
2	30	450	1	240	16	159,2	21,22	0,85	197	3,3
2	30	450	1,6	240	16	254,6	33,95	0,85	197	5,3
2	30	480	0,63	240	16	100,3	13,37	0,85	208	2,2
2	30	480	0,8	240	16	127,3	16,98	0,85	208	2,8
2	30	480	1	240	16	159,2	21,22	0,85	208	3,5
2	30	480	1,6	240	16	254,6	33,95	0,85	208	5,5
2	30	630	0,63	210	16	114,6	15,28	0,85	227	2,7
2	30	630	0,8	210	16	145,5	19,40	0,85	227	3,5
2	30	630	1	210	16	181,9	24,25	0,85	227	4,3
2	30	630	1,6	210	16	291,0	38,80	0,85	227	6,9
2	30	750	0,63	160	16	150,4	20,05	0,85	201	3,2



Tiro	Peso funi max	Portata	Velocità cabina	Ø Puleggia	Poli	Velocità	Frequenza	Efficienza vano	Coppia	Potenza in uscita
Roping Factor	Max Ropes Weight [kg]	Duty Load [kg]	Cabin Speed [m/s]	Sheave Diameter [mm]	Poles	Speed [rpm]	Frequency [Hz]	Shaft Efficiency	Torque [Nm]	Power Output [kW]
	(1)			(2) (3)				(4)		
2	30	750	0,8	160	16	191,0	25,46	0,85	201	4,0
2	30	750	1	160	16	238,7	31,83	0,85	201	5,0
2	30	800	0,63	160	16	150,4	20,05	0,85	212	3,3
2	30	800	0,8	160	16	191,0	25,46	0,85	212	4,2
2	30	800	1	160	16	238,7	31,83	0,85	212	5,3

C_Max [Nm] = 230

G-200 TS•TC - NOTES * Sheave diameter available only for G-200 TS.**Brake Type:** DF11 - 205 V DC Standard. Other voltages on request.**Static Load:** 2500 kg.**Encoder Type:** Absolute encoder with EnDat Interface or Incremental sin/cos, both with 2048 ppr;**Note 1:** For higher ropes weight, please consult sales/technical services of Alberto Sassi SpA.**Note 2:** Details on ropes/grooves provided upon lift data.**Note 3:** Suitable for steel core ropes or also for plastic coated ropes.**Note 4:** Shaft efficiency includes divertor pulleys efficiency by considering: 3 divertors for roping 2: 1. Values are supposed.**Note 5:** Max 180 sts/h - 40% ED with fans activated by thermocontacts inside motor.**Note 6:** DFX certified brake against Overspeed in upward direction and as UCM (EN 81-20:2014, EN 81-50:2014) with reference to Lift Directive 2014/33/EU.**Note 7:** G-200 TS: Traction sheave width 90 mm. Available width 120 mm; traction sheave Ø320 only with width 120 mm.
G-200 TC: Traction sheave width 90 mm. Available width 105 mm for Ø120, Ø140, Ø160 mm. Sheave Ø320 mm not available.*The Alberto Sassi SpA reserves the rights to change data and features without previous notice.***TIRO/ROPING 1/1 · Corsa / Travel 30 mt**

Portata Duty load [kg]	Velocità Speed [m/s]	Puleggia Sheave [mm]	** Combinazioni funi Ropes combination	N° Funi max, Max ropes nr.	Peso cabina Cabin weight [kg]
225	0,63 - 1,60	160 - 210 - 240	4÷6 x ø 6/6,5	8 x ø 6/6,5	300 450
320	0,63 - 1,60	160 - 210	5÷7 x ø 6/6,5	8 x ø 6/6,5	350 550
375	0,63 - 1,60	160	5÷7 x ø 6/6,5	8 x ø 6/6,5	400 500
400	0,63 - 1,60	160	5÷7 x ø 6/6,5	8 x ø 6/6,5	450 500

TIRO/ROPING 2/1 · Corsa / Travel 30 mt

Portata Duty load [kg]	Velocità Speed [m/s]	Puleggia Sheave [mm]	** Combinazioni funi Ropes combination	N° Funi max, Max ropes nr.	Peso cabina Cabin weight [kg]
225	0,63 - 1,60	160 - 210 - 240	3÷4 ø 6/6,5	8 x ø 6/6,5	400 500
320	0,63 - 1,60	160 - 210 - 240	4÷5 ø 6/6,5	8 x ø 6/6,5	500 600
375	0,63 - 1,60	160 - 210 - 240	4÷5 ø 6/6,5	8 x ø 6/6,5	500 600
450	0,63 - 1,60	160 - 210 - 240	5÷6 x ø 6/6,5	8 x ø 6/6,5	700 900
480	0,63 - 1,60	160 - 210 - 240	5÷6 x ø 6/6,5	8 x ø 6/6,5	700 900
525	0,63 - 1,60	160 - 210 - 240	5÷7 x ø 6/6,5	8 x ø 6/6,5	600 1000
630	0,63 - 1,60	160 - 210	5÷7 x ø 6/6,5	8 x ø 6/6,5	700 1000
800	0,63 - 1,60	160	6÷8 x ø 6/6,5	8 x ø 6/6,5	800 1000

** Altre combinazioni a richiesta / Additional combination on request

G-300

Gearless



G-300 T0•TS

G-300 T0 • TS • TC		Senza ventole di raffreddamento <i>Without cooling fan</i>					Con ventole di raffreddamento <i>With cooling fan</i>			
Carico statico <i>Static load [kg]</i>	2750 kg / 2500 kg*					2750 kg / 2500 kg*				
Coppia / <i>Rated torque</i>	270 Nm					320 Nm				
Peso / <i>Weight [kg]</i>	162 kg					165 kg				
Gamma velocità cabina <i>Range of cabin speed [m/s]</i>	0.63 ÷ 1.60									
Portata / <i>Duty load [kg]</i>	225	320	525	225 - 320	450	630	450	525	800	
Tiro / <i>Suspension</i>	1/1	1/1	1/1	2/1	2/1	2/1	1/1	2/1	2/1	
Gamma Ø pulegge <i>Range sheave Ø [mm]</i> G-300 T0•TS	120 → 320	120 → 240	120 → 160	120 → 240	120 → 320	120 → 240	210	320	210 - 240	
Gamma Ø pulegge <i>Range sheave Ø [mm]</i> G-300 TC	120 → 240	120 → 240	120 → 160	120 → 240	120 → 240	120 → 240	210	240	210 - 240	
Max combinazione funi <i>Max ropes combination</i>	n°10 Ø 6/ 6.5 6.7 mm n°8 Ø 8 mm	n°10 Ø 6 - 6.5 6.7 mm	n°6 Ø 6 - 8,1 mm	n°10 Ø 6/ 6.5 6.7 mm n°8 Ø 8 mm	n°10 Ø 6/ 6.5 6.7 mm n°8 Ø 8 mm	n°10 Ø 6- 6.5 6.7 mm	n°10 Ø 6 - 6,5 6,7 mm	n°10 Ø 6/ 6.5 6.7 mm n°8 Ø 8 mm	n°10 Ø 6- 6.5 6.7 mm	
Larghezza pulegge <i>Sheave width [mm]</i>	G-300 T0•TS = 120/150*					G-300 TC = 90/105				

16 Poles



G-300 TC

Con ventilatori / *With cooling fans*



G-300 TC

Senza ventilatori / *Without cooling fans*



G-300

Gearless

G-300 T1

Con o senza ventole di raffreddamento / *With or without cooling fans*

Carico statico <i>Static load [kg]</i>	2750 kg / 2500 kg*							
Coppia / <i>Rated torque</i>	430 Nm							
Peso / <i>Weight [kg]</i>	196 kg							
Gamma velocità cabina <i>Range of cabin speed [m/s]</i>	0.63 ÷ 1.60							
Portata / <i>Duty load [kg]</i>	225 - 320	400	525	630	800	450	630 - 800	1000
Tiro / <i>Suspension</i>	1/1	1/1	1/1	1/1	1/1	2/1	2/1	2/1
Gamma Ø pulegge <i>Range sheave Ø [mm]</i>	120 → 320	360 - 400	120 → 240	120 → 210	120 → 160	360 - 400	120 → 320	120 → 240
Max combinazione funi <i>Max ropes combination</i>	n°10 Ø 6 6,5/6,7 mm n°8 Ø 8 mm	n°8 Ø 8/10 mm	n°10 Ø 6/ 6,5/ 6,7 mm	n°10 Ø 6/6,5 6,7 mm	n°6 Ø 6/8,1 mm	n°8 Ø 9/10 mm	n°10 Ø 6 6,5/6,7 mm n°8 Ø 8 mm	n°10 Ø 6 mm
Larghezza pulegge <i>Sheave width [mm]</i>	120/150*							

16 Poles

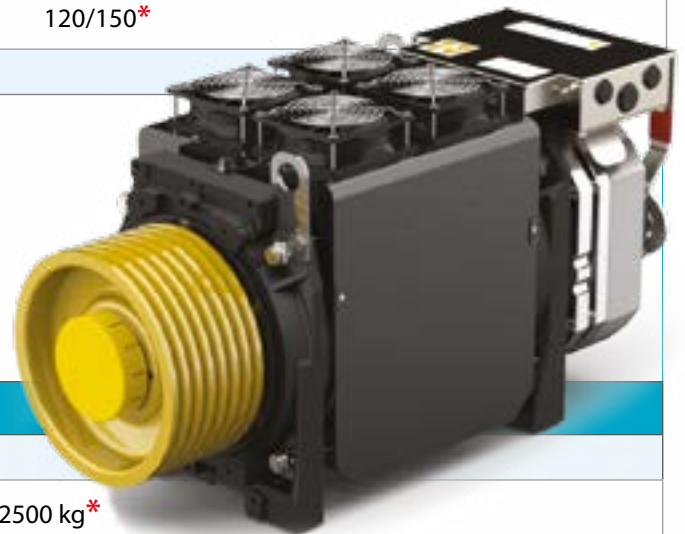

G-300 T2

Con ventole di raffreddamento / *With cooling fans*

Carico statico <i>Static load [kg]</i>	2750 kg / 2500 kg*				
Coppia / <i>Rated torque</i>	520 Nm				
Peso / <i>Weight [kg]</i>	208 kg				
Gamma velocità cabina <i>Range of cabin speed [m/s]</i>	0,63 ÷ 1,60				
Portata / <i>Duty load [kg]</i>	400	630	800	1000	1250
Tiro / <i>Suspension</i>	1/1	1/1	2/1	2/1	
Gamma Ø pulegge <i>Range sheave Ø [mm]</i>	360 - 400	210 - 240	360	210 - 240 - 320	210 - 240
Max combinazione funi <i>Max ropes combination</i>	n°8 Ø 9/10 mm	n°10 Ø 6 mm n°10 Ø 6,5/6,7 mm	n°8 Ø 9 mm	n°10 Ø 6/6,5/6,7 mm n°8 Ø 8 mm	n°10 Ø 6 mm n°10 Ø 6,5/6,7 mm
Larghezza pulegge <i>Sheave width [mm]</i>	120/150*				

16 Poles

* A richiesta disponibili: Leve apertura manuale freno

Available on request: Levers for hand release. G-300 T2 without cooling fans service limited to 90sts/h - 20% ED.



G-300 Con ventilatori / With cooling fans

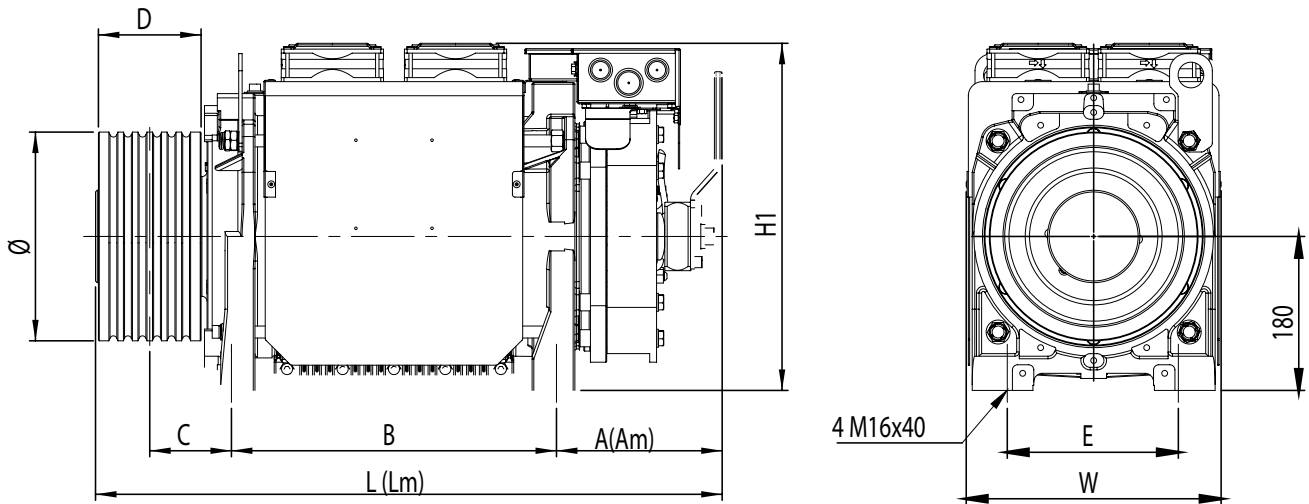

TIPO / TYPE	A	L	Am	Lm	B	C	E	W	H1	D	Ø
G-300 T0 / TS	147	577	192	622	264	95.5	200	296	405	120	210 - 240 - 320
	147	577	192	622	264	105.5	200	296	405	120	120 - 140 - 160
	147	605	192	650	264	110.5	200	296	405	150	240 - 320
G-300 T1	147	695	192	740	380	95.5	200	296	405	120	210 - 240 - 320 - 360 - 400
	147	695	192	740	380	105.5	200	296	405	120	120 - 140 - 160
	147	720	192	765	380	110.5	200	296	405	150	240 - 320 - 360 - 400
G-300 T2	178	726	223	771	380	95.5	200	296	405	120	210 - 240 - 320 - 360 - 400
	178	726	223	771	380	105.5	200	296	405	120	120 - 140 - 160
	178	751	223	796	380	110.5	200	296	405	150	240 - 320 - 360 - 400

G-300 Senza ventilatori / Without cooling fans

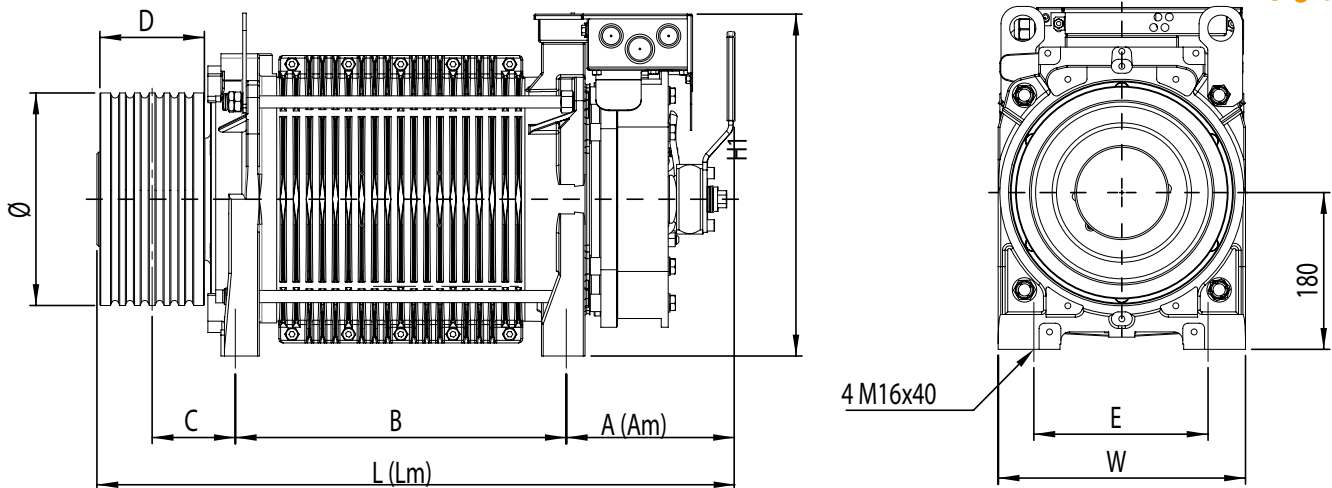

TIPO / TYPE	A	L	Am	Lm	B	C	E	W	H1	D	Ø
G-300 T0	147	577	192	622	264	95.5	200	284	395	120	210 - 240 - 320
	147	577	192	622	264	105.5	200	284	395	120	120 - 140 - 160
	147	605	192	650	264	110.5	200	284	395	150	240 - 320
G-300 T1	147	695	192	740	380	95.5	200	284	395	120	210 - 240 - 320 - 360 - 400
	147	695	192	740	380	105.5	200	284	395	120	120 - 140 - 160
	147	720	192	765	380	110.5	200	284	395	150	240 - 320 - 360 - 400



G-300 TC Senza ventilatori / Without cooling fans

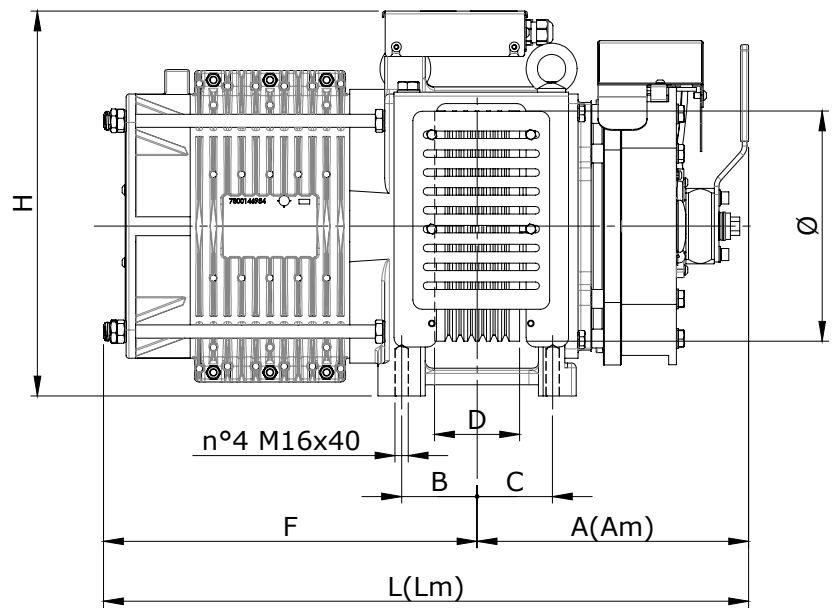
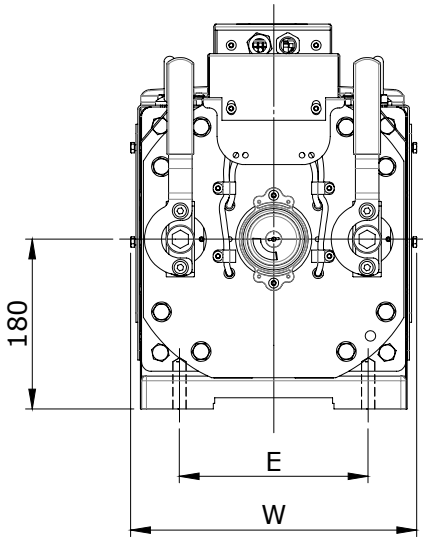

Am | **Lm**
 = quote con manovra apertura a mano
 = dimensions with lever for hand release
 = Abmessungen mit Hebel für Nothandlüftung



Unica direzione per l'uscita delle funi
Sole direction for ropes' exit

G-300 TC Con ventilatori / With cooling fans

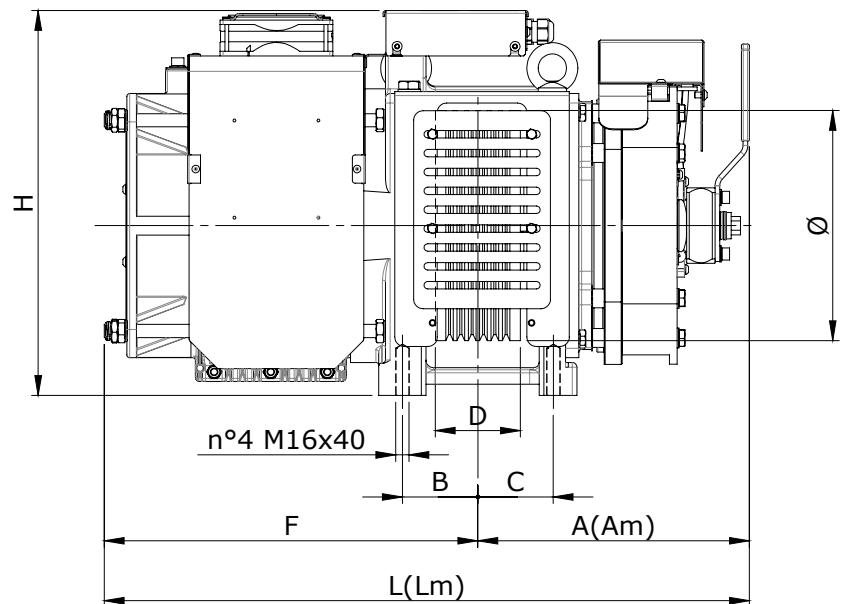
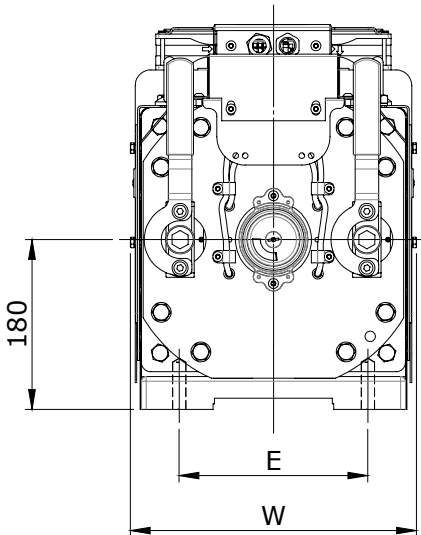

Unica direzione per l'uscita delle funi
Sole direction for ropes' exit

G-300 TC: encoder mounted on brake side

TIPO / TYPE	A	L	Am	Lm	B	C	E	F	W	H	D	Ø
G-300 TC	245	640	290	685	80	80	200	400	305	410	90	120 - 140 - 160 - 210 - 240
					87.5	72.5					105	120 - 140 - 160

G-300 T0•T1 IP66 Gearless



G-300 T0 IP66 Senza ventilatori / Without cooling fans *

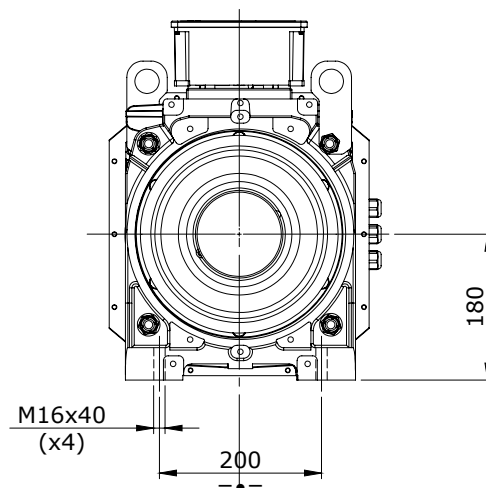
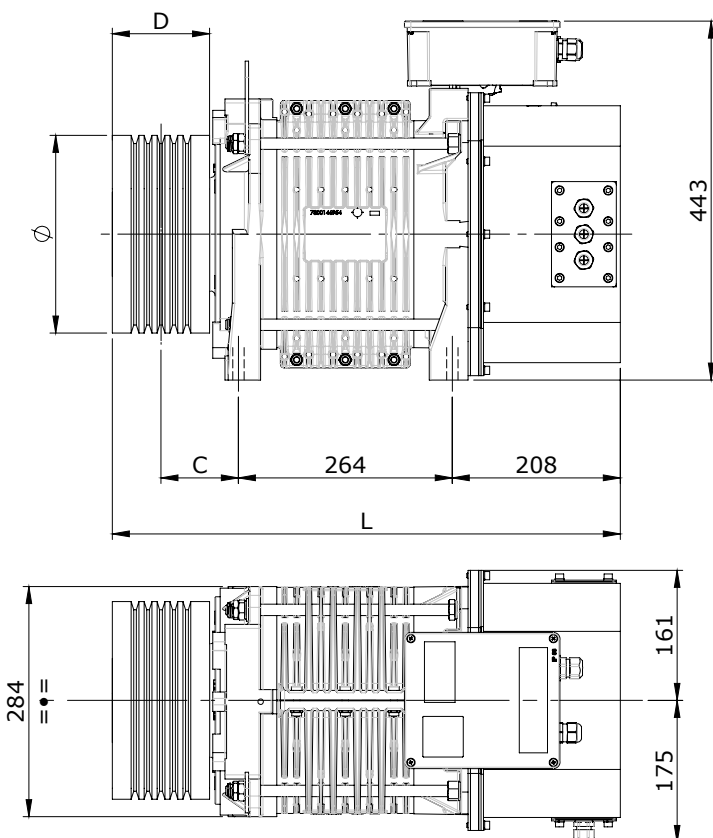

* configurazione solo senza ventilatore né leve del freno
only configuration without neither fan nor brake levers.

G-300 T1 IP66 Senza ventilatori / Without cooling fans *

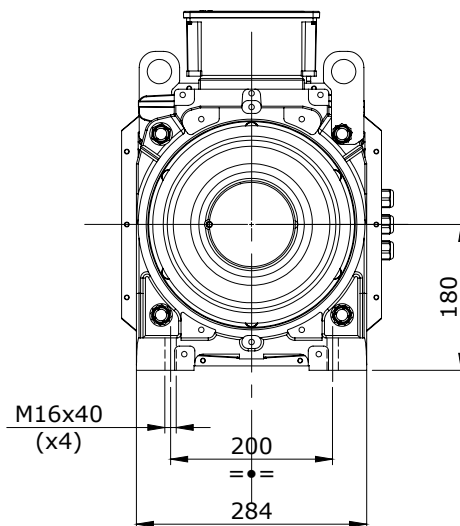
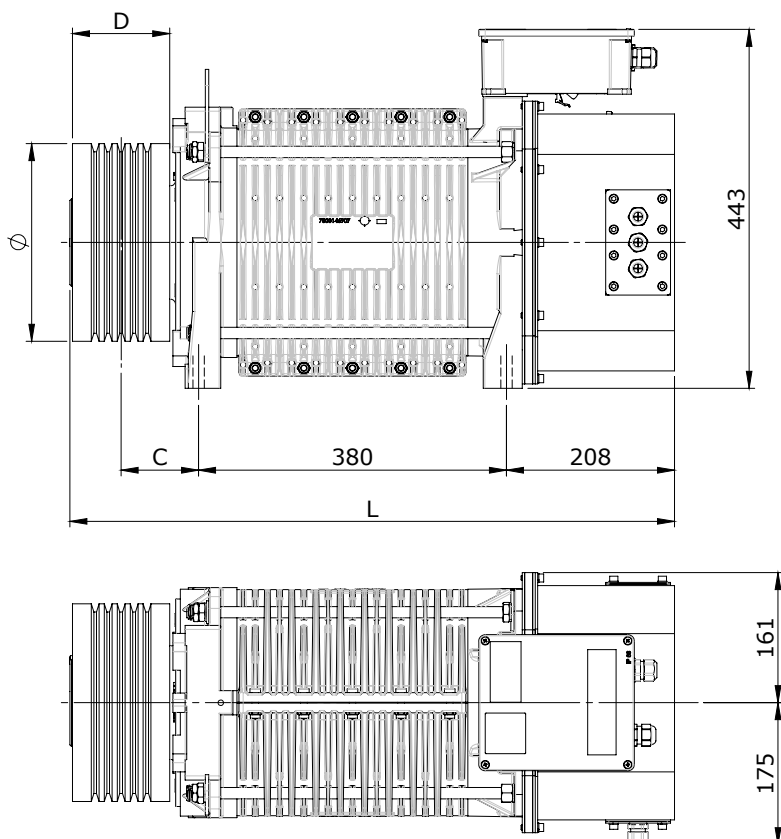

TIPO/TYP	L	C	D	Ø
G-300 T0	637	95.5	120	210 - 240 - 320
	637	105.5	120	120 - 140 - 160
	665	110.5	150	240 - 320
G-300 T1	755	95.5	120	210 - 240 - 320 - 360 - 400
	755	105.5	120	120 - 140 - 160
	780	110.5	150	240 - 320 - 360 - 400



G-300 T1 Con ventilatore speciale / With special cooling fan *

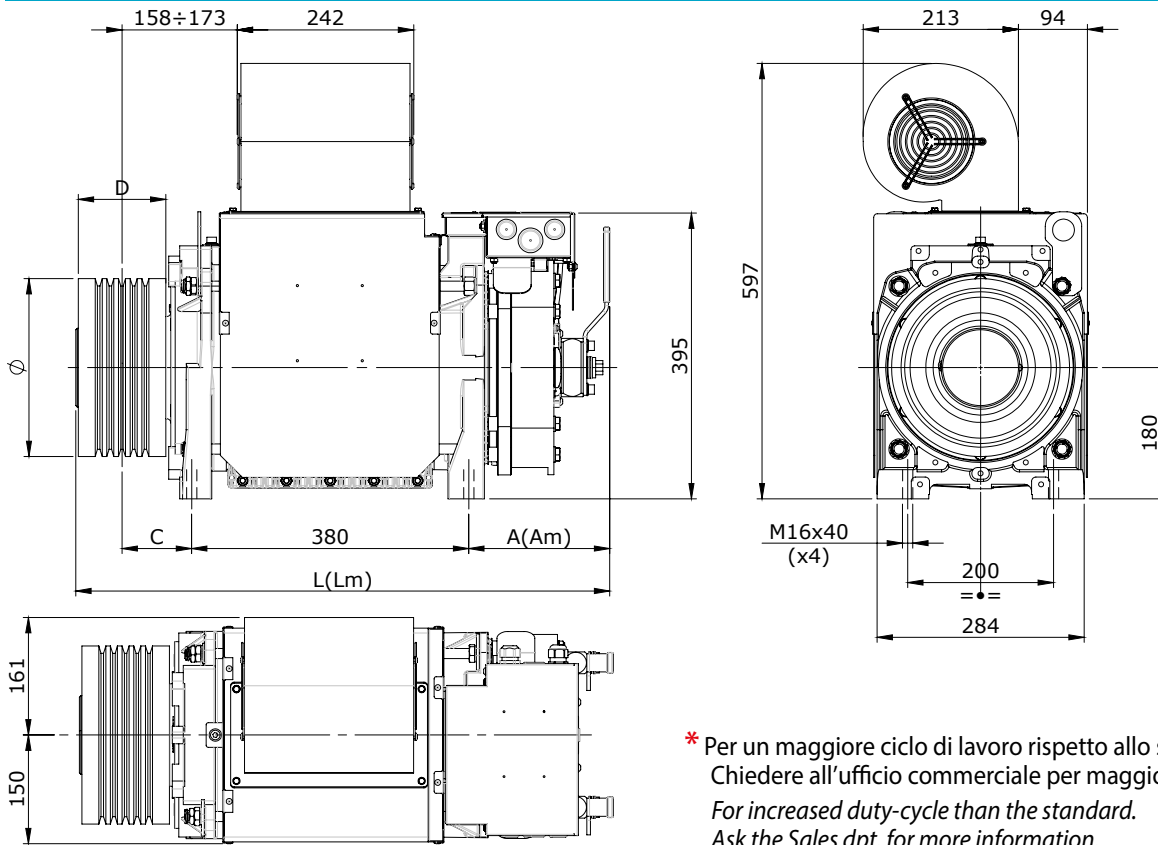

* Per un maggiore ciclo di lavoro rispetto allo standard.
Chiedere all'ufficio commerciale per maggiori informazioni
*For increased duty-cycle than the standard.
Ask the Sales dept. for more information.*

G-300 T2 Con ventilatore speciale / With special cooling fan *

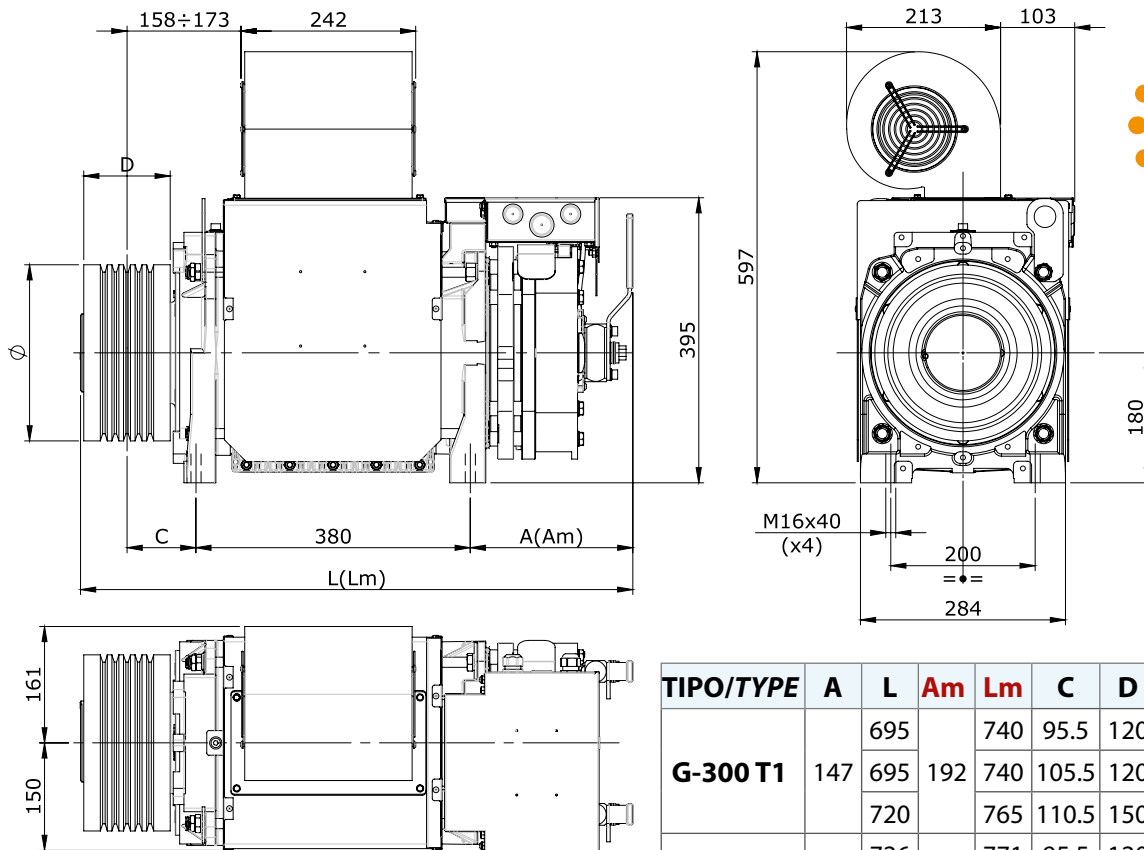

Am | Lm
= quote con manovra apertura a mano
= dimensions with lever for hand release
= Abmessungen mit Hebel für Nothandlüftung

TIPO/TYPE	A	L	Am	Lm	C	D	Ø
G-300 T1		695		740	95.5	120	210 - 240 - 320 - 360 - 400
	147	695	192	740	105.5	120	120 - 140 - 160
		720		765	110.5	150	240 - 320 - 360 - 400
G-300 T2		726		771	95.5	120	210 - 240 - 320 - 360 - 400
	178	726	223	771	105.5	120	120 - 140 - 160
		751		796	110.5	150	240 - 320 - 360 - 400



Tiro	Peso funi max	Portata	Velocità cabina	Ø Puleggia	Poli	Velocità	Frequenza	Efficienza vano	Coppia	Potenza in uscita
Roping Factor	Max Ropes Weight [kg]	Duty Load [kg]	Cabin Speed [m/s]	Sheave Diameter [mm]	Poles	Speed [rpm]	Frequency [Hz]	Shaft Efficiency	Torque [Nm]	Power Output [kW]
	(1)			(2) (3)				(4)		
1	30	225	0,63	120	16	100,3	13,37	0,85	99	1,0
1	30	225	0,63	140	16	85,9	11,46	0,85	115	1,0
1	30	225	0,63	160	16	75,2	10,03	0,85	132	1,0
1	30	225	0,63	210	16	57,3	7,64	0,85	173	1,0
1	30	225	0,63	240	16	50,1	6,68	0,85	197	1,0
1	30	225	0,63	320*	16	37,6	5,01	0,85	263	1,0
1	30	225	0,8	120	16	127,3	16,98	0,85	99	1,3
1	30	225	0,8	140	16	109,1	14,55	0,85	115	1,3
1	30	225	0,8	160	16	95,5	12,73	0,85	132	1,3
1	30	225	0,8	210	16	72,8	9,70	0,85	173	1,3
1	30	225	0,8	240	16	63,7	8,49	0,85	197	1,3
1	30	225	0,8	320*	16	47,7	6,37	0,85	263	1,3
1	30	225	1	120	16	159,2	21,22	0,85	99	1,6
1	30	225	1	140	16	136,4	18,19	0,85	115	1,6
1	30	225	1	160	16	119,4	15,92	0,85	132	1,6
1	30	225	1	210	16	90,9	12,13	0,85	173	1,6
1	30	225	1	240	16	79,6	10,61	0,85	197	1,6
1	30	225	1	320*	16	59,7	7,96	0,85	263	1,6
1	30	225	1,6	120	16	254,6	33,95	0,85	99	2,6
1	30	225	1,6	140	16	218,3	29,10	0,85	115	2,6
1	30	225	1,6	160	16	191,0	25,46	0,85	132	2,6
1	30	225	1,6	210	16	145,5	19,40	0,85	173	2,6
1	30	225	1,6	240	16	127,3	16,98	0,85	197	2,6
1	30	225	1,6	320*	16	95,5	12,73	0,85	263	2,6
1	30	300	0,63	120	16	100,3	13,37	0,85	125	1,3
1	30	300	0,63	140	16	85,9	11,46	0,85	145	1,3
1	30	300	0,63	160	16	75,2	10,03	0,85	166	1,3
1	30	300	0,63	210	16	57,3	7,64	0,85	218	1,3
1	30	300	0,63	240	16	50,1	6,68	0,85	249	1,3
1	30	300	0,8	120	16	127,3	16,98	0,85	125	1,7
1	30	300	0,8	140	16	109,1	14,55	0,85	145	1,7
1	30	300	0,8	160	16	95,5	12,73	0,85	166	1,7
1	30	300	0,8	210	16	72,8	9,70	0,85	218	1,7
1	30	300	0,8	240	16	63,7	8,49	0,85	249	1,7
1	30	300	1	120	16	159,2	21,22	0,85	125	2,1
1	30	300	1	140	16	136,4	18,19	0,85	145	2,1
1	30	300	1	160	16	119,4	15,92	0,85	166	2,1
1	30	300	1	210	16	90,9	12,13	0,85	218	2,1
1	30	300	1	240	16	79,6	10,61	0,85	249	2,1
1	30	300	1,6	120	16	254,6	33,95	0,85	125	3,3
1	30	300	1,6	140	16	218,3	29,10	0,85	145	3,3
1	30	300	1,6	160	16	191,0	25,46	0,85	166	3,3
1	30	300	1,6	210	16	145,5	19,40	0,85	218	3,3
1	30	300	1,6	240	16	127,3	16,98	0,85	249	3,3
1	30	375	0,63	120	16	100,3	13,37	0,85	151	1,6
1	30	375	0,63	140	16	85,9	11,46	0,85	176	1,6
1	30	375	0,63	160	16	75,2	10,03	0,85	201	1,6
1	30	375	0,63	210	16	57,3	7,64	0,85	264	1,6
1	30	375	0,8	120	16	127,3	16,98	0,85	151	2,0
1	30	375	0,8	140	16	109,1	14,55	0,85	176	2,0
1	30	375	0,8	160	16	95,5	12,73	0,85	201	2,0
1	30	375	0,8	210	16	72,8	9,70	0,85	264	2,0
1	30	375	1	120	16	159,2	21,22	0,85	151	2,5
1	30	375	1	140	16	136,4	18,19	0,85	176	2,5
1	30	375	1	160	16	119,4	15,92	0,85	201	2,5
1	30	375	1	210	16	90,9	12,13	0,85	264	2,5
1	30	375	1,6	120	16	254,6	33,95	0,85	151	4,0
1	30	375	1,6	140	16	218,3	29,10	0,85	176	4,0
1	30	375	1,6	160	16	191,0	25,46	0,85	201	4,0
1	30	375	1,6	210	16	145,5	19,40	0,85	264	4,0



Tiro	Peso funi max	Portata	Velocità cabina	Ø Puleggia	Poli	Velocità	Frequenza	Efficienza vano	Coppia	Potenza in uscita
Roping Factor	Max Ropes Weight [kg]	Duty Load [kg]	Cabin Speed [m/s]	Sheave Diameter [mm]	Poles	Speed [rpm]	Frequency [Hz]	Shaft Efficiency	Torque [Nm]	Power Output [kW]
	(1)			(2) (3)				(4)		
1	30	450	0,63	120	16	100,3	13,37	0,85	177	1,9
1	30	450	0,63	140	16	85,9	11,46	0,85	206	1,9
1	30	450	0,63	160	16	75,2	10,03	0,85	235	1,9
1	30	450	0,8	120	16	127,3	16,98	0,85	177	2,4
1	30	450	0,8	140	16	109,1	14,55	0,85	206	2,4
1	30	450	0,8	160	16	95,5	12,73	0,85	235	2,4
1	30	450	1	120	16	159,2	21,22	0,85	177	2,9
1	30	450	1	140	16	136,4	18,19	0,85	206	2,9
1	30	450	1	160	16	119,4	15,92	0,85	235	2,9
1	30	450	1,6	120	16	254,6	33,95	0,85	177	4,7
1	30	450	1,6	140	16	218,3	29,10	0,85	206	4,7
1	30	450	1,6	160	16	191,0	25,46	0,85	235	4,7
1	30	525	0,63	120	16	100,3	13,37	0,85	203	2,1
1	30	525	0,63	140	16	85,9	11,46	0,85	236	2,1
1	30	525	0,63	160	16	75,2	10,03	0,85	270	2,1
1	30	525	0,8	120	16	127,3	16,98	0,85	203	2,7
1	30	525	0,8	140	16	109,1	14,55	0,85	236	2,7
1	30	525	0,8	160	16	95,5	12,73	0,85	270	2,7
1	30	525	1	120	16	159,2	21,22	0,85	203	3,4
1	30	525	1	140	16	136,4	18,19	0,85	236	3,4
1	30	525	1	160	16	119,4	15,92	0,85	270	3,4
1	30	525	1,6	120	16	254,6	33,95	0,85	203	5,4
1	30	525	1,6	140	16	218,3	29,10	0,85	236	5,4
1	30	525	1,6	160	16	191,0	25,46	0,85	270	5,4
1	30	630	0,63	120	16	100,3	13,37	0,85	239	2,5
1	30	630	0,8	120	16	127,3	16,98	0,85	239	3,2
1	30	630	1	120	16	159,2	21,22	0,85	239	4,0
1	30	630	1,6	120	16	254,6	33,95	0,85	239	6,4
2	30	300	0,63	120	16	200,5	26,74	0,85	73	1,5
2	30	300	0,63	140	16	171,9	22,92	0,85	85	1,5
2	30	300	0,63	160	16	150,4	20,05	0,85	97	1,5
2	30	300	0,63	210	16	114,6	15,28	0,85	127	1,5
2	30	300	0,63	240	16	100,3	13,37	0,85	145	1,5
2	30	300	0,63	320*	16	75,2	10,03	0,85	194	1,5
2	30	300	0,63	360*	16	66,8	8,91	0,85	218	1,5
2	30	300	0,63	400*	16	60,2	8,02	0,85	242	1,5
2	30	300	0,8	120	16	254,6	33,95	0,85	73	1,9
2	30	300	0,8	140	16	218,3	29,10	0,85	85	1,9
2	30	300	0,8	160	16	191,0	25,46	0,85	97	1,9
2	30	300	0,8	210	16	145,5	19,40	0,85	127	1,9
2	30	300	0,8	240	16	127,3	16,98	0,85	145	1,9
2	30	300	0,8	320*	16	95,5	12,73	0,85	194	1,9
2	30	300	0,8	360*	16	84,9	11,32	0,85	218	1,9
2	30	300	0,8	400*	16	76,4	10,19	0,85	242	1,9
2	30	300	1	120	16	318,3	42,44	0,85	73	2,4
2	30	300	1	140	16	272,8	36,38	0,85	85	2,4
2	30	300	1	160	16	238,7	31,83	0,85	97	2,4
2	30	300	1	210	16	181,9	24,25	0,85	127	2,4
2	30	300	1	240	16	159,2	21,22	0,85	145	2,4
2	30	300	1	320*	16	119,4	15,92	0,85	194	2,4
2	30	300	1	360*	16	106,1	14,15	0,85	218	2,4
2	30	300	1	400*	16	95,5	12,73	0,85	242	2,4
2	30	300	1,6	210	16	291,0	38,80	0,85	127	3,9
2	30	300	1,6	240	16	254,6	33,95	0,85	145	3,9
2	30	300	1,6	320*	16	191,0	25,46	0,85	194	3,9
2	30	300	1,6	360*	16	169,8	22,64	0,85	218	3,9
2	30	300	1,6	400*	16	152,8	20,37	0,85	242	3,9
2	30	375	0,63	120	16	200,5	26,74	0,85	86	1,8
2	30	375	0,63	140	16	171,9	22,92	0,85	100	1,8
2	30	375	0,63	160	16	150,4	20,05	0,85	114	1,8



Tiro	Peso funi max	Portata	Velocità cabina	Ø Puleggia	Poli	Velocità	Frequenza	Efficienza vano	Coppia	Potenza in uscita
Roping Factor	Max Ropes Weight [kg]	Duty Load [kg]	Cabin Speed [m/s]	Sheave Diameter [mm]	Poles	Speed [rpm]	Frequency [Hz]	Shaft Efficiency	Torque [Nm]	Power Output [kW]
	(1)			(2) (3)				(4)		
2	30	375	0,63	210	16	114,6	15,28	0,85	150	1,8
2	30	375	0,63	240	16	100,3	13,37	0,85	171	1,8
2	30	375	0,63	320*	16	75,2	10,03	0,85	229	1,8
2	30	375	0,63	360*	16	66,8	8,91	0,85	257	1,8
2	30	375	0,8	120	16	254,6	33,95	0,85	86	2,3
2	30	375	0,8	140	16	218,3	29,10	0,85	100	2,3
2	30	375	0,8	160	16	191,0	25,46	0,85	114	2,3
2	30	375	0,8	210	16	145,5	19,40	0,85	150	2,3
2	30	375	0,8	240	16	127,3	16,98	0,85	171	2,3
2	30	375	0,8	320*	16	95,5	12,73	0,85	229	2,3
2	30	375	0,8	360*	16	84,9	11,32	0,85	257	2,3
2	30	375	1	120	16	318,3	42,44	0,85	86	2,9
2	30	375	1	140	16	272,8	36,38	0,85	100	2,9
2	30	375	1	160	16	238,7	31,83	0,85	114	2,9
2	30	375	1	210	16	181,9	24,25	0,85	150	2,9
2	30	375	1	240	16	159,2	21,22	0,85	171	2,9
2	30	375	1	320*	16	119,4	15,92	0,85	229	2,9
2	30	375	1	360*	16	106,1	14,15	0,85	257	2,9
2	30	375	1,6	210	16	291,0	38,80	0,85	150	4,6
2	30	375	1,6	240	16	254,6	33,95	0,85	171	4,6
2	30	375	1,6	320*	16	191,0	25,46	0,85	229	4,6
2	30	375	1,6	360*	16	169,8	22,64	0,85	257	4,6
2	30	450	0,63	120	16	200,5	26,74	0,85	99	2,1
2	30	450	0,63	140	16	171,9	22,92	0,85	115	2,1
2	30	450	0,63	160	16	150,4	20,05	0,85	132	2,1
2	30	450	0,63	210	16	114,6	15,28	0,85	173	2,1
2	30	450	0,63	240	16	100,3	13,37	0,85	197	2,1
2	30	450	0,63	320*	16	75,2	10,03	0,85	263	2,1
2	30	450	0,8	120	16	254,6	33,95	0,85	99	2,6
2	30	450	0,8	140	16	218,3	29,10	0,85	115	2,6
2	30	450	0,8	160	16	191,0	25,46	0,85	132	2,6
2	30	450	0,8	210	16	145,5	19,40	0,85	173	2,6
2	30	450	0,8	240	16	127,3	16,98	0,85	197	2,6
2	30	450	0,8	320*	16	95,5	12,73	0,85	263	2,6
2	30	450	1	120	16	318,3	42,44	0,85	99	3,3
2	30	450	1	140	16	272,8	36,38	0,85	115	3,3
2	30	450	1	160	16	238,7	31,83	0,85	132	3,3
2	30	450	1	210	16	181,9	24,25	0,85	173	3,3
2	30	450	1	240	16	159,2	21,22	0,85	197	3,3
2	30	450	1	320*	16	119,4	15,92	0,85	263	3,3
2	30	450	1,6	210	16	291,0	38,80	0,85	173	5,3
2	30	450	1,6	240	16	254,6	33,95	0,85	197	5,3
2	30	450	1,6	320*	16	191,0	25,46	0,85	263	5,3
2	30	525	0,63	120	16	200,5	26,74	0,85	112	2,3
2	30	525	0,63	140	16	171,9	22,92	0,85	130	2,3
2	30	525	0,63	160	16	150,4	20,05	0,85	149	2,3
2	30	525	0,63	210	16	114,6	15,28	0,85	195	2,3
2	30	525	0,63	240	16	100,3	13,37	0,85	223	2,3
2	30	525	0,8	120	16	254,6	33,95	0,85	112	3,0
2	30	525	0,8	140	16	218,3	29,10	0,85	130	3,0
2	30	525	0,8	160	16	191,0	25,46	0,85	149	3,0
2	30	525	0,8	210	16	145,5	19,40	0,85	195	3,0
2	30	525	0,8	240	16	127,3	16,98	0,85	223	3,0
2	30	525	1	120	16	318,3	42,44	0,85	112	3,7
2	30	525	1	140	16	272,8	36,38	0,85	130	3,7
2	30	525	1	160	16	238,7	31,83	0,85	149	3,7
2	30	525	1	210	16	181,9	24,25	0,85	195	3,7
2	30	525	1	240	16	159,2	21,22	0,85	223	3,7
2	30	525	1,6	210	16	291,0	38,80	0,85	195	6,0
2	30	525	1,6	240	16	254,6	33,95	0,85	223	6,0



Tiro <i>Roping Factor</i>	Peso funi max <i>Max Ropes Weight [kg]</i>	Portata <i>Duty Load [kg]</i>	Velocità cabina <i>Cabin Speed [m/s]</i>	Ø Puleggia <i>Sheave Diameter [mm]</i>	Poli <i>Poles</i>	Velocità <i>Speed [rpm]</i>	Frequenza <i>Frequency [Hz]</i>	Efficienza vano <i>Shaft Efficiency</i>	Coppia <i>Torque [Nm]</i>	Potenza in uscita <i>Power Output [kW]</i>
	(1)			(2) (3)				(4)		
2	30	630	0,63	120	16	200,5	26,74	0,85	130	2,7
2	30	630	0,63	140	16	171,9	22,92	0,85	151	2,7
2	30	630	0,63	160	16	150,4	20,05	0,85	173	2,7
2	30	630	0,63	210	16	114,6	15,28	0,85	227	2,7
2	30	630	0,63	240	16	100,3	13,37	0,85	260	2,7
2	30	630	0,8	120	16	254,6	33,95	0,85	130	3,5
2	30	630	0,8	140	16	218,3	29,10	0,85	151	3,5
2	30	630	0,8	160	16	191,0	25,46	0,85	173	3,5
2	30	630	0,8	210	16	145,5	19,40	0,85	227	3,5
2	30	630	0,8	240	16	127,3	16,98	0,85	260	3,5
2	30	630	1	120	16	318,3	42,44	0,85	130	4,3
2	30	630	1	140	16	272,8	36,38	0,85	151	4,3
2	30	630	1	160	16	238,7	31,83	0,85	173	4,3
2	30	630	1	210	16	181,9	24,25	0,85	227	4,3
2	30	630	1	240	16	159,2	21,22	0,85	260	4,3
2	30	630	1,6	210	16	291,0	38,80	0,85	227	6,9
2	30	630	1,6	240	16	254,6	33,95	0,85	260	6,9
2	30	750	0,63	120	16	200,5	26,74	0,85	151	3,2
2	30	750	0,63	140	16	171,9	22,92	0,85	176	3,2
2	30	750	0,63	160	16	150,4	20,05	0,85	201	3,2
2	30	750	0,63	210	16	114,6	15,28	0,85	264	3,2
2	30	750	0,8	120	16	254,6	33,95	0,85	151	4,0
2	30	750	0,8	140	16	218,3	29,10	0,85	176	4,0
2	30	750	0,8	160	16	191,0	25,46	0,85	201	4,0
2	30	750	0,8	210	16	145,5	19,40	0,85	264	4,0
2	30	750	1	120	16	318,3	42,44	0,85	151	5,0
2	30	750	1	140	16	272,8	36,38	0,85	176	5,0
2	30	750	1	160	16	238,7	31,83	0,85	201	5,0
2	30	750	1	210	16	181,9	24,25	0,85	264	5,0
2	30	750	1,6	210	16	291,0	38,80	0,85	264	8,0
2	30	800	0,63	120	16	200,5	26,74	0,85	159	3,3
2	30	800	0,63	140	16	171,9	22,92	0,85	186	3,3
2	30	800	0,63	160	16	150,4	20,05	0,85	212	3,3
2	30	800	0,8	120	16	254,6	33,95	0,85	159	4,2
2	30	800	0,8	140	16	218,3	29,10	0,85	186	4,2
2	30	800	0,8	160	16	191,0	25,46	0,85	212	4,2
2	30	800	1	120	16	318,3	42,44	0,85	159	5,3
2	30	800	1	140	16	272,8	36,38	0,85	186	5,3
2	30	800	1	160	16	238,7	31,83	0,85	212	5,3

G-300 T0•TC - NOTES * Sheave diameter available only for G-300 T0.

C_Max [Nm] = 270

- Brake Type:** G-300 T0: DF01 - Standard 205 V DC - Other voltages on request.
G-300 TC: DFA1 - Standard 205 V DC - Other voltages on request.
- Static Load:** G-300 T0: 2750 kg (2500 kg with sheave width 150 mm).
G-300 TC: 2750 kg.
- Encoder Type:** Absolute encoder with EnDat Interface or Incremental sin/cos, both with 2048 ppr;
- Note 1:** For higher ropes weight, please consult sales/technical services of Alberto Sassi SpA.
- Note 2:** Details on ropes/grooves provided upon lift data.
- Note 3:** Suitable for steel core ropes or also for plastic coated ropes.
- Note 4:** Shaft efficiency includes divertor pulleys efficiency by considering: 3 divertors for roping 2:1. Values are supposed.
- Note 5:** Max 240 sts/h - 40% ED without fans.
Max 240 sts/h - 50% ED with fans activated by thermocontacts inside motor.
- Note 6:** DFX certified brake against Overspeed in upward direction and as UCM (EN 81-20:2014, EN 81-50:2014) with reference to Lift Directive 2014/33/EU.
- Note 7:** G-300 T0: Traction sheave width 120 mm. Available width 150 mm for Ø240, Ø320, Ø360 and Ø400.
G-300 TC: Traction sheave width 90 mm. Available width 105 mm for Ø120, Ø140, Ø160 mm.
- Note 8:** Weight 162 kg.

The Alberto Sassi SpA reserves the rights to change data and features without previous notice.



Tiro <i>Roping Factor</i>	Peso funi max <i>Max Ropes Weight [kg]</i>	Portata <i>Duty Load [kg]</i>	Velocità cabina <i>Cabin Speed [m/s]</i>	Ø Puleggia <i>Sheave Diameter [mm]</i>	Poli <i>Poles</i>	Velocità <i>Speed [rpm]</i>	Frequenza <i>Frequency [Hz]</i>	Efficienza vano <i>Shaft Efficiency</i>	Coppia <i>Torque [Nm]</i>	Potenza in uscita <i>Power Output [kW]</i>
	(1)			(2) (3)				(4)		
1	30	375	0,63	240	16	50,1	6,68	0,85	301	1,6
1	30	375	0,8	240	16	63,7	8,49	0,85	301	2,0
1	30	375	1	240	16	79,6	10,61	0,85	301	2,5
1	30	375	1,6	240	16	127,3	16,98	0,85	301	4,0
1	30	450	0,63	210	16	57,3	7,64	0,85	309	1,9
1	30	450	0,8	210	16	72,8	9,70	0,85	309	2,4
1	30	450	1	210	16	90,9	12,13	0,85	309	2,9
1	30	450	1,6	210	16	145,5	19,40	0,85	309	4,7
1	30	525	0,63	160	16	75,2	10,03	0,85	270	2,1
1	30	525	0,8	160	16	95,5	12,73	0,85	270	2,7
1	30	525	1	160	16	119,4	15,92	0,85	270	3,4
1	30	525	1,6	160	16	191,0	25,46	0,85	270	5,4
1	30	630	0,63	120	16	100,3	13,37	0,85	239	2,5
1	30	630	0,63	140	16	85,9	11,46	0,85	279	2,5
1	30	630	0,63	160	16	75,2	10,03	0,85	319	2,5
1	30	630	0,8	120	16	127,3	16,98	0,85	239	3,2
1	30	630	0,8	140	16	109,1	14,55	0,85	279	3,2
1	30	630	0,8	160	16	95,5	12,73	0,85	319	3,2
1	30	630	1	120	16	159,2	21,22	0,85	239	4,0
1	30	630	1	140	16	136,4	18,19	0,85	279	4,0
1	30	630	1	160	16	119,4	15,92	0,85	319	4,0
1	30	630	1,6	120	16	254,6	33,95	0,85	239	6,4
1	30	630	1,6	140	16	218,3	29,10	0,85	279	6,4
1	30	630	1,6	160	16	191,0	25,46	0,85	319	6,4
1	30	800	0,63	120	16	100,3	13,37	0,85	298	3,1
1	30	800	0,8	120	16	127,3	16,98	0,85	298	4,0
1	30	800	1	120	16	159,2	21,22	0,85	298	5,0
1	30	800	1,6	120	16	254,6	33,95	0,85	298	7,9
2	30	375	0,63	400*	16	60,2	8,02	0,85	286	1,8
2	30	375	0,8	400*	16	76,4	10,19	0,85	286	2,3
2	30	375	1	400*	16	95,5	12,73	0,85	286	2,9
2	30	375	1,6	400*	16	152,8	20,37	0,85	286	4,6
2	30	450	0,63	360*	16	66,8	8,91	0,85	296	2,1
2	30	450	0,8	360*	16	84,9	11,32	0,85	296	2,6
2	30	450	1	360*	16	106,1	14,15	0,85	296	3,3
2	30	450	1,6	360*	16	169,8	22,64	0,85	296	5,3
2	30	525	0,63	320*	16	75,2	10,03	0,85	298	2,3
2	30	525	0,8	320*	16	95,5	12,73	0,85	298	3,0
2	30	525	1	320*	16	119,4	15,92	0,85	298	3,7
2	30	525	1,6	320*	16	191,0	25,46	0,85	298	6,0
2	30	630	0,63	240	16	100,3	13,37	0,85	260	2,7
2	30	630	0,8	240	16	127,3	16,98	0,85	260	3,5
2	30	630	1	240	16	159,2	21,22	0,85	260	4,3
2	30	630	1,6	240	16	254,6	33,95	0,85	260	6,9
2	30	750	0,63	240	16	100,3	13,37	0,85	301	3,2
2	30	750	0,8	240	16	127,3	16,98	0,85	301	4,0
2	30	750	1	240	16	159,2	21,22	0,85	301	5,0
2	30	750	1,6	240	16	254,6	33,95	0,85	301	8,0
2	30	800	0,63	210	16	114,6	15,28	0,85	279	3,3
2	30	800	0,63	240	16	100,3	13,37	0,85	319	3,3
2	30	800	0,8	210	16	145,5	19,40	0,85	279	4,2



Tiro Roping Factor	Peso funi max Max Ropes Weight [kg]	Portata Duty Load [kg]	Velocità cabina Cabin Speed [m/s]	Ø Puleggia Sheave Diameter [mm]	Poli Poles	Velocità Speed [rpm]	Frequenza Frequency [Hz]	Efficienza vano Shaft Efficiency	Coppia Torque [Nm]	Potenza in uscita Power Output [kW]
	(1)			(2) (3)				(4)		
2	30	800	0,8	240	16	127,3	16,98	0,85	319	4,2
2	30	800	1	210	16	181,9	24,25	0,85	279	5,3
2	30	800	1	240	16	159,2	21,22	0,85	319	5,3
2	30	800	1,6	210	16	291,0	38,80	0,85	279	8,5
2	30	800	1,6	240	16	254,6	33,95	0,85	319	8,5

G-300 TS•TC - NOTES * Sheave diameter available only for G-300 TS.
C_Max [Nm] = 320

- Brake Type:** G-300 TS: DF01 - Standard 205 V DC - Other voltages on request.
G-300 TC: DFA1 - Standard 205 V DC - Other voltages on request.
- Static Load:** G-300TS: 2750 kg (2500 kg with sheave width 150 mm)
G-300TC: 2750 kg.
- Encoder Type:** Absolute encoder with EnDat Interface or Incremental sin/cos, both with 2048 ppr;
- Note 1:** For higher ropes weight, please consult sales/technical services of Alberto Sassi SpA.
- Note 2:** Details on ropes/grooves provided upon lift data.
- Note 3:** Suitable for steel core ropes or also for plastic coated ropes.
- Note 4:** Shaft efficiency includes divertor pulleys efficiency by considering: 3 divertors for roping 2:1. Values are supposed.
- Note 5:** Max 180 sts/h - 40% ED with fans activated by thermocontacts inside motor.
- Note 6:** DFXY certified brake against Overspeed in upward direction and as UCM (EN 81-20:2014, EN 81-50:2014) with reference to Lift Directive 2014/33/EU.
- Note 7:** G-300 TS: Traction sheave width 120 mm. Available width 150 mm for Ø240, Ø320, Ø360 and Ø400.
G-300 TC: Traction sheave width 90 mm. Available width 105 mm for Ø120, Ø140, Ø160 mm.
- Note 8:** Weight 165 kg.

The Alberto Sassi SpA reserves the rights to change data and features without previous notice.



Tiro <i>Roping Factor</i>	Peso funi max <i>Max Ropes Weight [kg]</i>	Portata <i>Duty Load [kg]</i>	Velocità cabina <i>Cabin Speed [m/s]</i>	Ø Puleggia <i>Sheave Diameter [mm]</i>	Poli <i>Poles</i>	Velocità <i>Speed [rpm]</i>	Frequenza <i>Frequency [Hz]</i>	Efficienza vano <i>Shaft Efficiency</i>	Coppia <i>Torque [Nm]</i>	Potenza in uscita <i>Power Output [kW]</i>
	(1)			(2) (3)				(4)		
1	30	300	0,63	120	16	100,3	13,37	0,85	125	1,3
1	30	300	0,63	140	16	85,9	11,46	0,85	145	1,3
1	30	300	0,63	160	16	75,2	10,03	0,85	166	1,3
1	30	300	0,63	210	16	57,3	7,64	0,85	218	1,3
1	30	300	0,63	240	16	50,1	6,68	0,85	249	1,3
1	30	300	0,63	320	16	37,6	5,01	0,85	332	1,3
1	30	300	0,8	120	16	127,3	16,98	0,85	125	1,7
1	30	300	0,8	140	16	109,1	14,55	0,85	145	1,7
1	30	300	0,8	160	16	95,5	12,73	0,85	166	1,7
1	30	300	0,8	210	16	72,8	9,70	0,85	218	1,7
1	30	300	0,8	240	16	63,7	8,49	0,85	249	1,7
1	30	300	0,8	320	16	47,7	6,37	0,85	332	1,7
1	30	300	0,8	360	16	42,4	5,66	0,85	374	1,7
1	30	300	0,8	400	16	38,2	5,09	0,85	415	1,7
1	30	300	1	120	16	159,2	21,22	0,85	125	2,1
1	30	300	1	140	16	136,4	18,19	0,85	145	2,1
1	30	300	1	160	16	119,4	15,92	0,85	166	2,1
1	30	300	1	210	16	90,9	12,13	0,85	218	2,1
1	30	300	1	240	16	79,6	10,61	0,85	249	2,1
1	30	300	1	320	16	59,7	7,96	0,85	332	2,1
1	30	300	1	360	16	53,1	7,07	0,85	374	2,1
1	30	300	1	400	16	47,7	6,37	0,85	415	2,1
1	30	300	1,6	120	16	254,6	33,95	0,85	125	3,3
1	30	300	1,6	140	16	218,3	29,10	0,85	145	3,3
1	30	300	1,6	160	16	191,0	25,46	0,85	166	3,3
1	30	300	1,6	210	16	145,5	19,40	0,85	218	3,3
1	30	300	1,6	240	16	127,3	16,98	0,85	249	3,3
1	30	300	1,6	320	16	95,5	12,73	0,85	332	3,3
1	30	300	1,6	360	16	84,9	11,32	0,85	374	3,3
1	30	300	1,6	400	16	76,4	10,19	0,85	415	3,3
1	30	375	0,63	120	16	100,3	13,37	0,85	151	1,6
1	30	375	0,63	140	16	85,9	11,46	0,85	176	1,6
1	30	375	0,63	160	16	75,2	10,03	0,85	201	1,6
1	30	375	0,63	210	16	57,3	7,64	0,85	264	1,6
1	30	375	0,63	240	16	50,1	6,68	0,85	301	1,6
1	30	375	0,63	320	16	37,6	5,01	0,85	402	1,6
1	30	375	0,8	120	16	127,3	16,98	0,85	151	2,0
1	30	375	0,8	140	16	109,1	14,55	0,85	176	2,0
1	30	375	0,8	160	16	95,5	12,73	0,85	201	2,0
1	30	375	0,8	210	16	72,8	9,70	0,85	264	2,0
1	30	375	0,8	240	16	63,7	8,49	0,85	301	2,0
1	30	375	0,8	320	16	47,7	6,37	0,85	402	2,0
1	30	375	1	120	16	159,2	21,22	0,85	151	2,5
1	30	375	1	140	16	136,4	18,19	0,85	176	2,5
1	30	375	1	160	16	119,4	15,92	0,85	201	2,5
1	30	375	1	210	16	90,9	12,13	0,85	264	2,5
1	30	375	1	240	16	79,6	10,61	0,85	301	2,5
1	30	375	1	320	16	59,7	7,96	0,85	402	2,5
1	30	375	1,6	120	16	254,6	33,95	0,85	151	4,0
1	30	375	1,6	140	16	218,3	29,10	0,85	176	4,0
1	30	375	1,6	160	16	191,0	25,46	0,85	201	4,0
1	30	375	1,6	210	16	145,5	19,40	0,85	264	4,0
1	30	375	1,6	240	16	127,3	16,98	0,85	301	4,0
1	30	375	1,6	320	16	95,5	12,73	0,85	402	4,0
1	30	400	0,63	120	16	100,3	13,37	0,85	159	1,7
1	30	400	0,63	140	16	85,9	11,46	0,85	186	1,7
1	30	400	0,63	160	16	75,2	10,03	0,85	212	1,7
1	30	400	0,63	210	16	57,3	7,64	0,85	279	1,7
1	30	400	0,63	240	16	50,1	6,68	0,85	319	1,7
1	30	400	0,63	320	16	37,6	5,01	0,85	425	1,7
1	30	400	0,8	120	16	127,3	16,98	0,85	159	2,1
1	30	400	0,8	140	16	109,1	14,55	0,85	186	2,1



Tiro	Peso funi max	Portata	Velocità cabina	Ø Puleggia	Poli	Velocità	Frequenza	Efficienza vano	Coppia	Potenza in uscita
Roping Factor	Max Ropes Weight [kg]	Duty Load [kg]	Cabin Speed [m/s]	Sheave Diameter [mm]	Poles	Speed [rpm]	Frequency [Hz]	Shaft Efficiency	Torque [Nm]	Power Output [kW]
	(1)			(2) (3)				(4)		
1	30	400	0,8	160	16	95,5	12,73	0,85	212	2,1
1	30	400	0,8	210	16	72,8	9,70	0,85	279	2,1
1	30	400	0,8	240	16	63,7	8,49	0,85	319	2,1
1	30	400	0,8	320	16	47,7	6,37	0,85	425	2,1
1	30	400	1	120	16	159,2	21,22	0,85	159	2,7
1	30	400	1	140	16	136,4	18,19	0,85	186	2,7
1	30	400	1	160	16	119,4	15,92	0,85	212	2,7
1	30	400	1	210	16	90,9	12,13	0,85	279	2,7
1	30	400	1	240	16	79,6	10,61	0,85	319	2,7
1	30	400	1	320	16	59,7	7,96	0,85	425	2,7
1	30	400	1,6	120	16	254,6	33,95	0,85	159	4,2
1	30	400	1,6	140	16	218,3	29,10	0,85	186	4,2
1	30	400	1,6	160	16	191,0	25,46	0,85	212	4,2
1	30	400	1,6	210	16	145,5	19,40	0,85	279	4,2
1	30	400	1,6	240	16	127,3	16,98	0,85	319	4,2
1	30	400	1,6	320	16	95,5	12,73	0,85	425	4,2
1	30	450	0,63	120	16	100,3	13,37	0,85	177	1,9
1	30	450	0,63	140	16	85,9	11,46	0,85	206	1,9
1	30	450	0,63	160	16	75,2	10,03	0,85	235	1,9
1	30	450	0,63	210	16	57,3	7,64	0,85	309	1,9
1	30	450	0,63	240	16	50,1	6,68	0,85	353	1,9
1	30	450	0,8	120	16	127,3	16,98	0,85	177	2,4
1	30	450	0,8	140	16	109,1	14,55	0,85	206	2,4
1	30	450	0,8	160	16	95,5	12,73	0,85	235	2,4
1	30	450	0,8	210	16	72,8	9,70	0,85	309	2,4
1	30	450	0,8	240	16	63,7	8,49	0,85	353	2,4
1	30	450	1	120	16	159,2	21,22	0,85	177	2,9
1	30	450	1	140	16	136,4	18,19	0,85	206	2,9
1	30	450	1	160	16	119,4	15,92	0,85	235	2,9
1	30	450	1	210	16	90,9	12,13	0,85	309	2,9
1	30	450	1	240	16	79,6	10,61	0,85	353	2,9
1	30	450	1,6	120	16	254,6	33,95	0,85	177	4,7
1	30	450	1,6	140	16	218,3	29,10	0,85	206	4,7
1	30	450	1,6	160	16	191,0	25,46	0,85	235	4,7
1	30	450	1,6	210	16	145,5	19,40	0,85	309	4,7
1	30	450	1,6	240	16	127,3	16,98	0,85	353	4,7
1	30	630	0,63	120	16	100,3	13,37	0,85	239	2,5
1	30	630	0,63	140	16	85,9	11,46	0,85	279	2,5
1	30	630	0,63	160	16	75,2	10,03	0,85	319	2,5
1	30	630	0,63	210	16	57,3	7,64	0,85	418	2,5
1	30	630	0,8	120	16	127,3	16,98	0,85	239	3,2
1	30	630	0,8	140	16	109,1	14,55	0,85	279	3,2
1	30	630	0,8	160	16	95,5	12,73	0,85	319	3,2
1	30	630	0,8	210	16	72,8	9,70	0,85	418	3,2
1	30	630	1	120	16	159,2	21,22	0,85	239	4,0
1	30	630	1	140	16	136,4	18,19	0,85	279	4,0
1	30	630	1	160	16	119,4	15,92	0,85	319	4,0
1	30	630	1	210	16	90,9	12,13	0,85	418	4,0
1	30	630	1,6	120	16	254,6	33,95	0,85	239	6,4
1	30	630	1,6	140	16	218,3	29,10	0,85	279	6,4
1	30	630	1,6	160	16	191,0	25,46	0,85	319	6,4
1	30	630	1,6	210	16	145,5	19,40	0,85	418	6,4
1	30	800	0,63	120	16	100,3	13,37	0,85	298	3,1
1	30	800	0,63	140	16	85,9	11,46	0,85	347	3,1
1	30	800	0,63	160	16	75,2	10,03	0,85	397	3,1
1	30	800	0,8	120	16	127,3	16,98	0,85	298	4,0
1	30	800	0,8	140	16	109,1	14,55	0,85	347	4,0
1	30	800	0,8	160	16	95,5	12,73	0,85	397	4,0
1	30	800	1	120	16	159,2	21,22	0,85	298	5,0
1	30	800	1	140	16	136,4	18,19	0,85	347	5,0
1	30	800	1	160	16	119,4	15,92	0,85	397	5,0
1	30	800	1,6	120	16	254,6	33,95	0,85	298	7,9

G-300 T1 Gearless



Tiro <i>Roping Factor</i>	Peso funi max <i>Max Ropes Weight [kg]</i>	Portata <i>Duty Load [kg]</i>	Velocità cabina <i>Cabin Speed [m/s]</i>	Ø Puleggia <i>Sheave Diameter [mm]</i>	Poli <i>Poles</i>	Velocità <i>Speed [rpm]</i>	Frequenza <i>Frequency [Hz]</i>	Efficienza vano <i>Shaft Efficiency</i>	Coppia <i>Torque [Nm]</i>	Potenza in uscita <i>Power Output [kW]</i>
	(1)			(2) (3)				(4)		
1	30	800	1,6	140	16	218,3	29,10	0,85	347	7,9
1	30	800	1,6	160	16	191,0	25,46	0,85	397	7,9
2	30	450	0,63	120	16	200,5	26,74	0,85	99	2,1
2	30	450	0,63	140	16	171,9	22,92	0,85	115	2,1
2	30	450	0,63	160	16	150,4	20,05	0,85	132	2,1
2	30	450	0,63	210	16	114,6	15,28	0,85	173	2,1
2	30	450	0,63	240	16	100,3	13,37	0,85	197	2,1
2	30	450	0,63	320	16	75,2	10,03	0,85	263	2,1
2	30	450	0,63	360	16	66,8	8,91	0,85	296	2,1
2	30	450	0,63	400	16	60,2	8,02	0,85	329	2,1
2	30	450	0,8	120	16	254,6	33,95	0,85	99	2,6
2	30	450	0,8	140	16	218,3	29,10	0,85	115	2,6
2	30	450	0,8	160	16	191,0	25,46	0,85	132	2,6
2	30	450	0,8	210	16	145,5	19,40	0,85	173	2,6
2	30	450	0,8	240	16	127,3	16,98	0,85	197	2,6
2	30	450	0,8	320	16	95,5	12,73	0,85	263	2,6
2	30	450	0,8	360	16	84,9	11,32	0,85	296	2,6
2	30	450	0,8	400	16	76,4	10,19	0,85	329	2,6
2	30	450	1	120	16	318,3	42,44	0,85	99	3,3
2	30	450	1	140	16	272,8	36,38	0,85	115	3,3
2	30	450	1	160	16	238,7	31,83	0,85	132	3,3
2	30	450	1	210	16	181,9	24,25	0,85	173	3,3
2	30	450	1	240	16	159,2	21,22	0,85	197	3,3
2	30	450	1	320	16	119,4	15,92	0,85	263	3,3
2	30	450	1	360	16	106,1	14,15	0,85	296	3,3
2	30	450	1	400	16	95,5	12,73	0,85	329	3,3
2	30	450	1,6	210	16	291,0	38,80	0,85	173	5,3
2	30	450	1,6	240	16	254,6	33,95	0,85	197	5,3
2	30	450	1,6	320	16	191,0	25,46	0,85	263	5,3
2	30	450	1,6	360	16	169,8	22,64	0,85	296	5,3
2	30	450	1,6	400	16	152,8	20,37	0,85	329	5,3
2	30	630	0,63	120	16	200,5	26,74	0,85	130	2,7
2	30	630	0,63	140	16	171,9	22,92	0,85	151	2,7
2	30	630	0,63	160	16	150,4	20,05	0,85	173	2,7
2	30	630	0,63	210	16	114,6	15,28	0,85	227	2,7
2	30	630	0,63	240	16	100,3	13,37	0,85	260	2,7
2	30	630	0,63	320	16	75,2	10,03	0,85	346	2,7
2	30	630	0,63	360	16	66,8	8,91	0,85	390	2,7
2	30	630	0,8	120	16	254,6	33,95	0,85	130	3,5
2	30	630	0,8	140	16	218,3	29,10	0,85	151	3,5
2	30	630	0,8	160	16	191,0	25,46	0,85	173	3,5
2	30	630	0,8	210	16	145,5	19,40	0,85	227	3,5
2	30	630	0,8	240	16	127,3	16,98	0,85	260	3,5
2	30	630	0,8	320	16	95,5	12,73	0,85	346	3,5
2	30	630	0,8	360	16	84,9	11,32	0,85	390	3,5
2	30	630	1	120	16	318,3	42,44	0,85	130	4,3
2	30	630	1	140	16	272,8	36,38	0,85	151	4,3
2	30	630	1	160	16	238,7	31,83	0,85	173	4,3
2	30	630	1	210	16	181,9	24,25	0,85	227	4,3
2	30	630	1	240	16	159,2	21,22	0,85	260	4,3
2	30	630	1	320	16	119,4	15,92	0,85	346	4,3
2	30	630	1	360	16	106,1	14,15	0,85	390	4,3
2	30	630	1,6	210	16	291,0	38,80	0,85	227	6,9
2	30	630	1,6	240	16	254,6	33,95	0,85	260	6,9
2	30	630	1,6	320	16	191,0	25,46	0,85	346	6,9
2	30	630	1,6	360	16	169,8	22,64	0,85	390	6,9
2	30	800	0,63	120	16	200,5	26,74	0,85	159	3,3
2	30	800	0,63	140	16	171,9	22,92	0,85	186	3,3
2	30	800	0,63	160	16	150,4	20,05	0,85	212	3,3
2	30	800	0,63	210	16	114,6	15,28	0,85	279	3,3
2	30	800	0,63	240	16	100,3	13,37	0,85	319	3,3
2	30	800	0,63	320	16	75,2	10,03	0,85	425	3,3



Tiro <i>Roping Factor</i>	Peso funi max <i>Max Ropes Weight [kg]</i>	Portata <i>Duty Load [kg]</i>	Velocità cabina <i>Cabin Speed [m/s]</i>	Ø Puleggia <i>Sheave Diameter [mm]</i>	Poli <i>Poles</i>	Velocità <i>Speed [rpm]</i>	Frequenza <i>Frequency [Hz]</i>	Efficienza vano <i>Shaft Efficiency</i>	Coppia <i>Torque [Nm]</i>	Potenza in uscita <i>Power Output [kW]</i>
	(1)			(2) (3)				(4)		
2	30	800	0,8	120	16	254,6	33,95	0,85	159	4,2
2	30	800	0,8	140	16	218,3	29,10	0,85	186	4,2
2	30	800	0,8	160	16	191,0	25,46	0,85	212	4,2
2	30	800	0,8	210	16	145,5	19,40	0,85	279	4,2
2	30	800	0,8	240	16	127,3	16,98	0,85	319	4,2
2	30	800	0,8	320	16	95,5	12,73	0,85	425	4,2
2	30	800	1	120	16	318,3	42,44	0,85	159	5,3
2	30	800	1	140	16	272,8	36,38	0,85	186	5,3
2	30	800	1	160	16	238,7	31,83	0,85	212	5,3
2	30	800	1	210	16	181,9	24,25	0,85	279	5,3
2	30	800	1	240	16	159,2	21,22	0,85	319	5,3
2	30	800	1	320	16	119,4	15,92	0,85	425	5,3
2	30	800	1,6	210	16	291,0	38,80	0,85	279	8,5
2	30	800	1,6	240	16	254,6	33,95	0,85	319	8,5
2	30	800	1,6	320	16	191,0	25,46	0,85	425	8,5
2	30	1000	0,63	120	16	200,5	26,74	0,85	194	4,1
2	30	1000	0,63	140	16	171,9	22,92	0,85	226	4,1
2	30	1000	0,63	160	16	150,4	20,05	0,85	259	4,1
2	30	1000	0,63	210	16	114,6	15,28	0,85	339	4,1
2	30	1000	0,63	240	16	100,3	13,37	0,85	388	4,1
2	30	1000	0,8	120	16	254,6	33,95	0,85	194	5,2
2	30	1000	0,8	140	16	218,3	29,10	0,85	226	5,2
2	30	1000	0,8	160	16	191,0	25,46	0,85	259	5,2
2	30	1000	0,8	210	16	145,5	19,40	0,85	339	5,2
2	30	1000	0,8	240	16	127,3	16,98	0,85	388	5,2
2	30	1000	1	120	16	318,3	42,44	0,85	194	6,5
2	30	1000	1	140	16	272,8	36,38	0,85	226	6,5
2	30	1000	1	160	16	238,7	31,83	0,85	259	6,5
2	30	1000	1	210	16	181,9	24,25	0,85	339	6,5
2	30	1000	1	240	16	159,2	21,22	0,85	388	6,5
2	30	1000	1,6	210	16	291,0	38,80	0,85	339	10,3
2	30	1000	1,6	240	16	254,6	33,95	0,85	388	10,3
2	30	1250	0,63	120	16	200,5	26,74	0,85	237	5,0
2	30	1250	0,63	140	16	171,9	22,92	0,85	277	5,0
2	30	1250	0,63	160	16	150,4	20,05	0,85	316	5,0
2	30	1250	0,63	210	16	114,6	15,28	0,85	415	5,0
2	30	1250	0,8	120	16	254,6	33,95	0,85	237	6,3
2	30	1250	0,8	140	16	218,3	29,10	0,85	277	6,3
2	30	1250	0,8	160	16	191,0	25,46	0,85	316	6,3
2	30	1250	0,8	210	16	145,5	19,40	0,85	415	6,3
2	30	1250	1	120	16	318,3	42,44	0,85	237	7,9
2	30	1250	1	140	16	272,8	36,38	0,85	277	7,9
2	30	1250	1	160	16	238,7	31,83	0,85	316	7,9
2	30	1250	1	210	16	181,9	24,25	0,85	415	7,9
2	30	1250	1,6	210	16	291,0	38,80	0,85	415	12,6

G-300 T1 - NOTE

C_Max [Nm] = 430

Brake Type: DF01 - Standard 205 V DC - Other voltages on request.

Static Load: Static load 2750 kg (2500 kg with sheave width 150 mm).

Encoder Type: Absolute encoder with EnDat Interface or Incremental sin/cos, both with 2048 ppr;

Note 1: For higher ropes weight, please consult sales/technical services of Alberto Sassi SpA.

Note 2: Details on ropes/grooves provided upon lift data.

Note 3: Suitable for steel core ropes or also for plastic coated ropes.

Note 4: Shaft efficiency includes divertor pulleys efficiency by considering: 3 divertors for roping 2:1. Values are supposed.

Note 5: Max 240 sts/h - 40% ED without fans.
Max 240 sts/h - 50% ED with fans activated by thermocontacts inside motor.

Note 6: DFX certified brake against Overspeed in upward direction and as UCM (EN 81-20:2014, EN 81-50:2014) with reference to Lift Directive 2014/33/EU.

Note 7: Traction sheave width: 120 mm. Available width 150 mm for Ø240, Ø320, Ø360 and Ø400.

Note 8: Weight 196 kg.

The Alberto Sassi SpA reserves the rights to change data and features without previous notice.



Tiro <i>Roping Factor</i>	Peso funi max <i>Max Ropes Weight [kg]</i>	Portata <i>Duty Load [kg]</i>	Velocità cabina <i>Cabin Speed [m/s]</i>	Ø Puleggia <i>Sheave Diameter [mm]</i>	Poli <i>Poles</i>	Velocità <i>Speed [rpm]</i>	Frequenza <i>Frequency [Hz]</i>	Efficienza vano <i>Shaft Efficiency</i>	Coppia <i>Torque [Nm]</i>	Potenza in uscita <i>Power Output [kW]</i>
	(1)			(2) (3)				(4)		
1	30	375	0,8	360	16	42,4	5,66	0,85	452	2,0
1	30	375	0,8	400	16	38,2	5,09	0,85	502	2,0
1	30	375	1	360	16	53,1	7,07	0,85	452	2,5
1	30	375	1	400	16	47,7	6,37	0,85	502	2,5
1	30	375	1,6	360	16	84,9	11,32	0,85	452	4,0
1	30	375	1,6	400	16	76,4	10,19	0,85	502	4,0
1	30	400	0,8	360	16	42,4	5,66	0,85	478	2,1
1	30	400	1	360	16	53,1	7,07	0,85	478	2,7
1	30	400	1,6	360	16	84,9	11,32	0,85	478	4,2
1	30	450	0,63	320	16	37,6	5,01	0,85	471	1,9
1	30	450	0,8	320	16	47,7	6,37	0,85	471	2,4
1	30	450	1	320	16	59,7	7,96	0,85	471	2,9
1	30	450	1,6	320	16	95,5	12,73	0,85	471	4,7
1	30	630	0,63	240	16	50,1	6,68	0,85	478	2,5
1	30	630	0,8	240	16	63,7	8,49	0,85	478	3,2
1	30	630	1	240	16	79,6	10,61	0,85	478	4,0
1	30	630	1,6	240	16	127,3	16,98	0,85	478	6,4
2	30	630	0,63	400	16	60,2	8,02	0,85	433	2,7
2	30	630	0,8	400	16	76,4	10,19	0,85	433	3,5
2	30	630	1	400	16	95,5	12,73	0,85	433	4,3
2	30	630	1,6	400	16	152,8	20,37	0,85	433	6,9
2	30	800	0,63	360	16	66,8	8,91	0,85	478	3,3
2	30	800	0,8	360	16	84,9	11,32	0,85	478	4,2
2	30	800	1	360	16	106,1	14,15	0,85	478	5,3
2	30	800	1,6	360	16	169,8	22,64	0,85	478	8,5
2	30	1000	0,63	320	16	75,2	10,03	0,85	517	4,1
2	30	1000	0,8	320	16	95,5	12,73	0,85	517	5,2
2	30	1000	1	320	16	119,4	15,92	0,85	517	6,5
2	30	1000	1,6	320	16	191,0	25,46	0,85	517	10,3
2	30	1250	0,63	240	16	100,3	13,37	0,85	474	5,0
2	30	1250	0,8	240	16	127,3	16,98	0,85	474	6,3
2	30	1250	1	240	16	159,2	21,22	0,85	474	7,9
2	30	1250	1,6	240	16	254,6	33,95	0,85	474	12,6

C_Max [Nm] = 520

G-300 T2 - NOTE

Brake Type: DF02 - Standard 205 V DC - Other voltages on request.

Static Load: Static load 2750 kg (2500 kg with sheave width 150 mm).

Encoder Type: Absolute encoder with EnDat Interface or Incremental sin/cos, both with 2048 ppr;

Note 1: For higher ropes weight, please consult sales/technical services of Alberto Sassi SpA.

Note 2: Details on ropes/grooves provided upon lift data.

Note 3: Suitable for steel core ropes or also for plastic coated ropes.

Note 4: Shaft efficiency includes divertor pulleys efficiency by considering: 3 divertors for roping 2:1. Values are supposed.

Note 5: Max 180 sts/h - 40% ED with fans activated by thermocontacts inside motor.

Note 6: DFX certified brake against Overspeed in upward direction and as UCM (EN 81-20:2014, EN 81-50:2014) with reference to Lift Directive 2014/33/EU.

Note 7: Traction sheave width: 120 mm. Available width 150 mm for Ø240, Ø320, Ø360 and Ø400.

Note 8: Weight 208 kg.

The Alberto Sassi SpA reserves the rights to change data and features without previous notice.



TIRO/ROPING 1/1 • Corsa/Travel 30 mt						
Portata Duty load [kg]	Velocità Speed [m/s]	Puleggia Sheave [mm]	* Combinazioni funi Ropes combination	N° Funi max. Max ropes nr.	Peso cabina Cabin weight [kg]	
225	0,63 – 1,60	210-240	4÷6 x ø 6/6,5	8÷10 x ø 6/6,5	350	450
	0,63 – 1,60	320	3÷4 x ø 8	10 x ø 8		
	0,63 – 1,60	360	3 x ø 9	10 x ø 9		
	0,63 – 1,60	400	3 x ø 10	10 x ø 10		
320	0,63 – 1,60	210-240	5÷7 x ø 6/6,5	8÷10 x ø 6/6,5	450	550
	0,63 – 1,60	320	4÷5 x ø 8	10 x ø 8		
	0,63 – 1,60	360	3 x ø 9	10 x ø 9		
	0,63 – 1,60	400	3 x ø 10	10 x ø 10		
450	0,63 – 1,60	210 - 240	6÷8 x ø 6/6,5	8÷10 x ø 6/6,5	650	850
	0,63 – 1,60	320	4 x ø 8	10 x ø 8		
525	0,63 – 1,60	160 - 210 - 240	6÷8 x ø 6/6,5	8÷10 x ø 6/6,5	650	750
630	0,63 – 1,60	160 - 210	6÷8 x ø 6/6,5	8÷10 x ø 6/6,5	650	775
	0,63 – 1,60	240	6÷8 x ø 6/6,5	10 x ø 6/6,5		
800	0,63 – 1,60	160	8 x ø 6/6,5	8 x ø 6/6,5	600	675

TIRO/ROPING 2/1 • Corsa/Travel 30 mt						
Portata Duty load [kg]	Velocità Speed [m/s]	Puleggia Sheave [mm]	* Combinazioni funi Ropes combination	N° Funi max. Max ropes nr.	Peso cabina Cabin weight [kg]	
225	0,63 – 1,60	160 - 210 - 240	3÷4 ø 6/6,5	8÷10 x ø 6/6,5	400	500
	0,63 – 1,60	320	3÷4 x ø 8	10 x ø 8		
	0,63 – 1,60	360	3 x ø 9	10 x ø 9		
	0,63 – 1,60	400	3 x ø 10	10 x ø 10		
320	0,63 – 1,60	160 - 210 - 240	4÷5 ø 6/6,5	8÷10 x ø 6/6,5	500	600
	0,63 – 1,60	320	3÷4 x ø 8	10 x ø 8		
	0,63 – 1,60	360	3 x ø 9	10 x ø 9		
	0,63 – 1,60	400	3 x ø 10	10 x ø 10		
450	0,63 – 1,60	160 - 210 - 240	5÷6 x ø 6/6,5	8÷10 x ø 6/6,5	700	90
	0,63 – 1,60	320	4÷5 x ø 8	10 x ø 8		
	0,63 – 1,60	360	3÷4 x ø 9	10 x ø 9		
	0,63 – 1,60	400	3 x ø 10	10 x ø 10		
630	0,63 – 1,60	160 - 210 - 240	5÷7 x ø 6/6,5	8÷10 x ø 6/6,5	900	1100
	0,63 – 1,60	320	5÷6 x ø 8	10 x ø 8		
	0,63 – 1,60	360	4÷5 x ø 9	10 x ø 9		
	0,63 – 1,60	400	4 x ø 10	10 x ø 10		
800	0,63 – 1,60	160 - 210 - 240	6÷7x ø 6/6,5	8÷10 x ø 6/6,5	900	1250
	0,63 – 1,60	320	5÷6 x ø 8	10 x ø 8		
	0,63 – 1,60	360	5÷6 x ø 9	10 x ø 9		
1000	0,63 – 1,60	160 - 210 - 240	7÷8x ø 6/6,5	8÷10 x ø 6/6,5	1200	1400
	0,63 – 1,60	320	6 x ø 8	10 x ø 8		
1250	0,63 – 1,60	240	8 x ø 6/6,5	10 x ø 6/6,5	1250	1500

* Altre combinazioni a richiesta
Additional combination on request



G-400 T1

Con o senza ventole di raffreddamento
With or without cooling fans

Carico statico / <i>Static load</i>	3500 kg					
Coppia / <i>Nominal torque</i>	640 Nm					
Peso / <i>Weight</i>	245 kg					
Portata / <i>Duty load</i> [kg]	480	630	630	800	1000	1250
Tiro / <i>Suspension</i>	1/1	1/1	2/1	2/1	2/1	2/1
Gamma velocità cabina <i>Range of cabin speed</i> [m/s]	0,63 ÷ 2,50	0,63 ÷ 2,50	0,63 ÷ 2,50	0,63 ÷ 2,50	0,63 ÷ 2,00	0,63 ÷ 2,00
Gamma Ø pulegge <i>Range sheave Ø</i> [mm]	210 → 400	210 - 240 320	210 → 560	210 → 480	210 → 360	210 - 240 320

16 poles

Freno/ *Brake* DF02

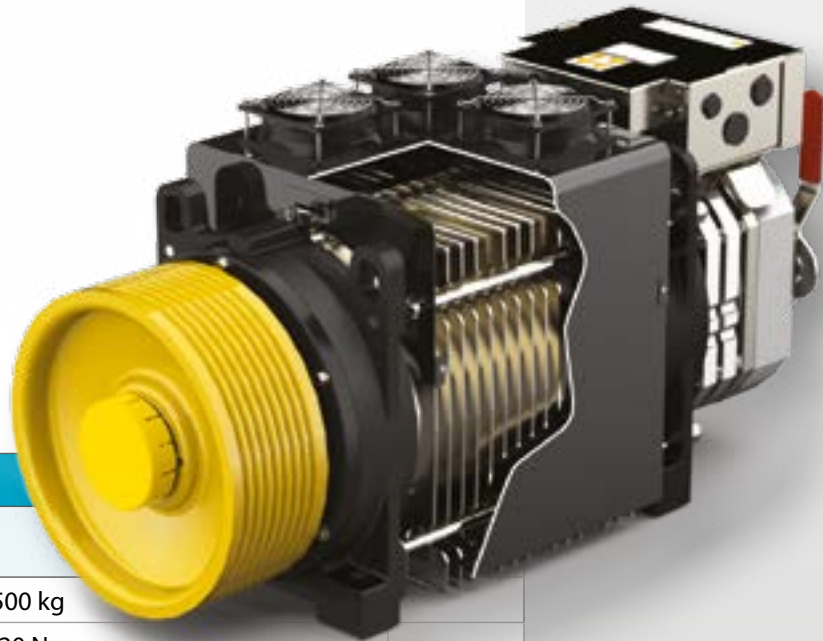

G-400 T2

Con o senza ventole di raffreddamento
With or without cooling fans

Carico statico / <i>Static load</i>	4500 kg					
Coppia / <i>Rated torque</i>	1020 Nm					
Peso / <i>Weight</i>	356 kg					
Portata / <i>Duty load</i> [kg]	630	800	1000	630 - 800 - 1000	1600	2000
Tiro / <i>Suspension</i>	1/1	1/1	1/1	2/1	2/1	2/1
Gamma velocità cabina <i>Range of cabin speed</i> [m/s]	0,63 ÷ 2,50	0,63 ÷ 2,50	0,63 ÷ 2,50	0,63 ÷ 2,50	0,63 ÷ 2,00	0,63 ÷ 2,00
Gamma Ø pulegge <i>Range sheave Ø</i> [mm]	210 → 480	210 → 360	210 - 240 320	210 → 560	210 → 360	240 - 320

16 poles

Freno/ *Brake* DF03

A richiesta disponibili:
Leve apertura
manuale freno.

Available on request:
Levers for hand release.



G-400 Gearless



G-400 T3

Con ventole di raffreddamento / *With cooling fans*

Carico statico / <i>Static load</i>	5200 kg					
Coppia / <i>Rated torque</i>	1250 Nm					
Peso / <i>Weight</i>	364 kg					
Portata / <i>Duty load</i> [kg]	630	1000	1250	1000	1600	2000
Tiro / <i>Suspension</i>	1/1	1/1	1/1	2/1	2/1	2/1
Gamma velocità cabina <i>Range of cabin speed</i> [m/s]	0,63 ÷ 2,50	0,63 ÷ 2,50	0,63 ÷ 2,50	0,63 ÷ 2,50	0,63 ÷ 2,50	0,63 ÷ 2,50
Gamma Ø pulegge <i>Range sheave Ø</i> [mm]	520 - 560 - 600	320 - 360 - 400	320	600 - 650	360 → 480	320 - 360 - 400

16 poles

Freno/ *Brake* DQ03



G-400 T1 con ventilatori / with cooling fans

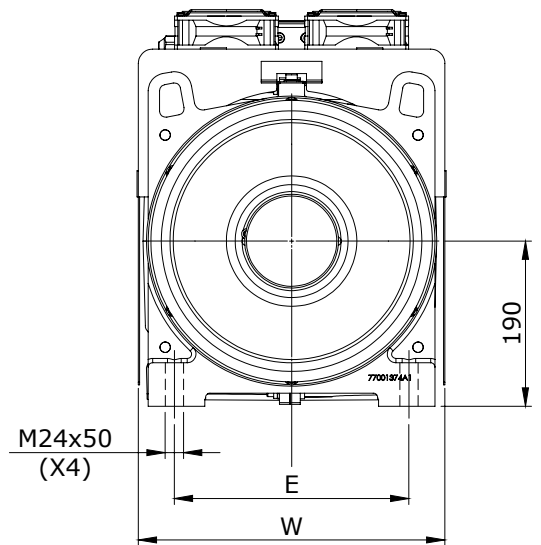
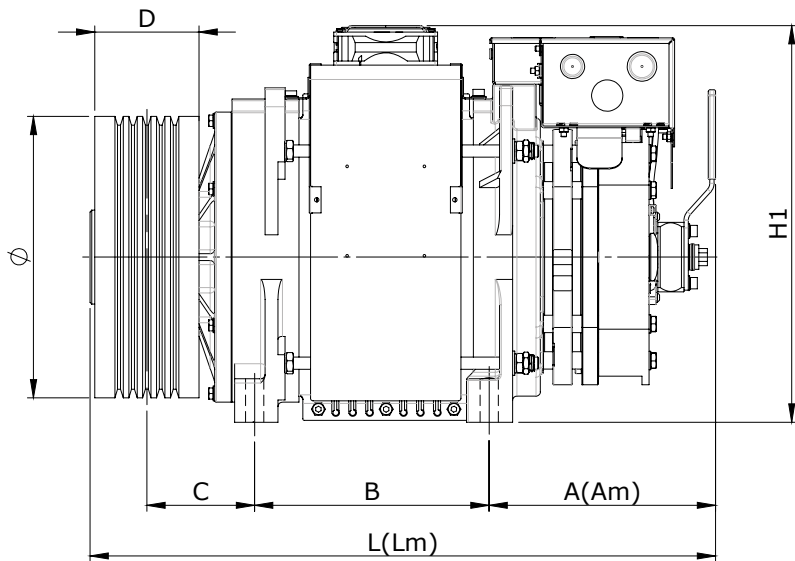

TIPO/TYPE G-400 T1	A	L	Am	Lm	B	C	E	W	H1	D	Ø
con carter ventilazione with cooling fans	215	670	260	715	270	124	270	356	456	120*	210 - 240 - 320 - 360 - 400 450 - 480 - 520 - 560 - 600
		700		745		139				150	240 - 320 - 360 - 400
senza carter ventilazione without cooling fans	215	670	260	715	270	124	270	330	445	120*	210 - 240 - 320 - 360 - 400 450 - 480 - 520 - 560 - 600
		700		745		139				150	240 - 320 - 360 - 400

* Ø > 400 mm: pulegge con flangia e "D" = 115 mm
 Ø > 400 mm: flanged traction sheave with "D" = 115 mm



G-400 T1 senza ventilatori / Without cooling fans

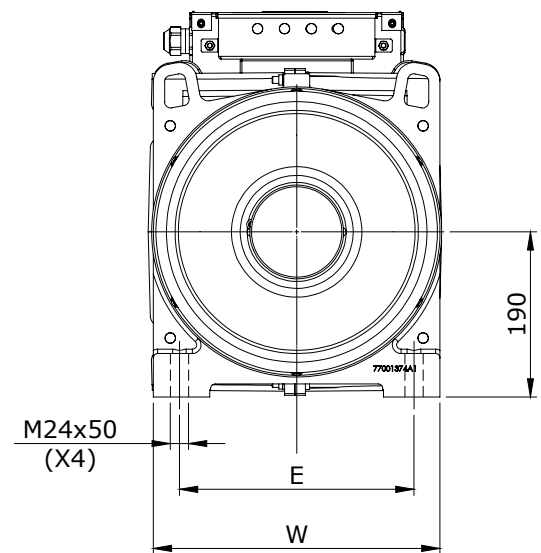
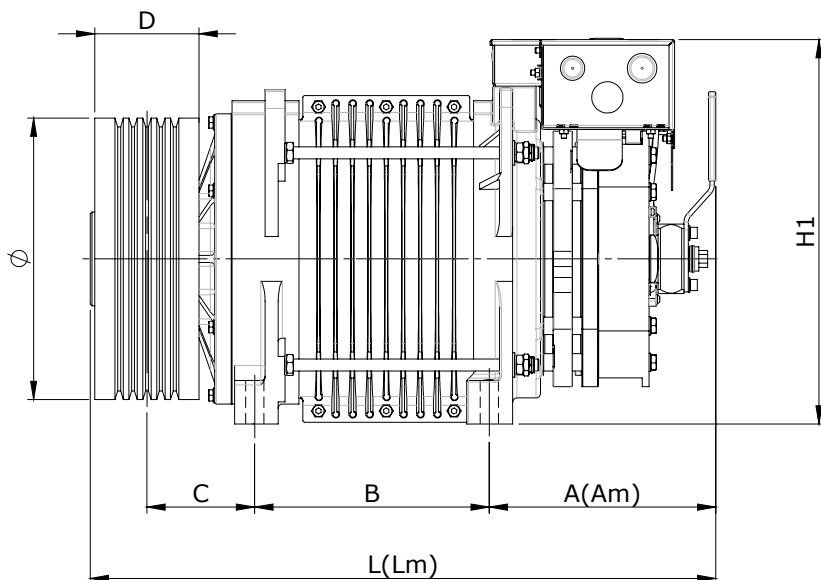



G-400 T2 con ventilatori / with cooling fans

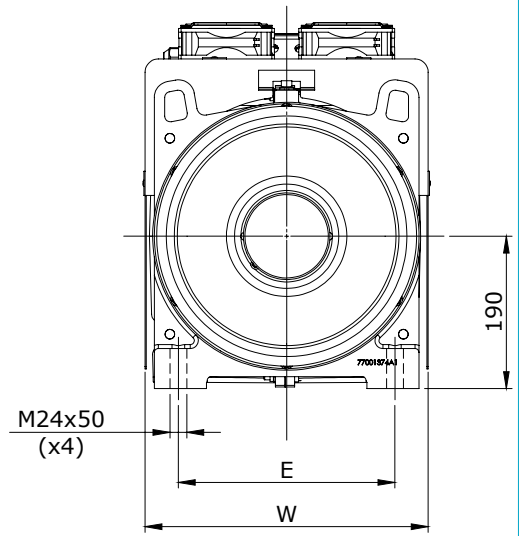
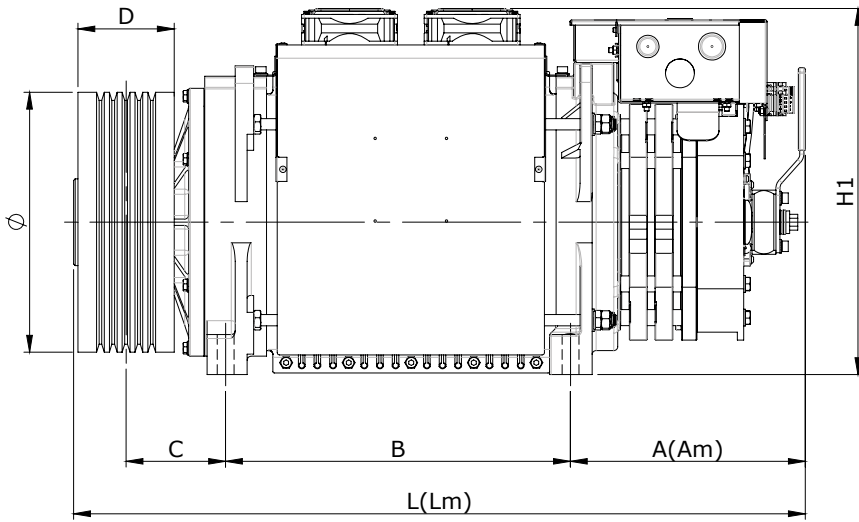

TIPO/TYPER G-400 T2	A	L	Am	Lm	B	C	E	W	H1	D	Ø
con carter ventilazione with cooling fans	247	862	292	907	430	124	270	356	456	120*	210 - 240 - 320 - 360 - 400 450 - 480 - 520 - 560 - 600 - 650
		892		937		139				150	240 - 320 - 360 - 400
senza carter ventilazione without cooling fans	247	862	292	907	430	124	270	330	445	120*	210 - 240 - 320 - 360 - 400 450 - 480 - 520 - 560 - 600 - 650
		892		937		139				150	240 - 320 - 360 - 400

* Ø > 400 mm: pulegge con flangia e "D" = 115 mm
 Ø > 400 mm: flanged traction sheave with "D" = 115 mm

Am | **Lm**

= quote con manovra
 apertura a mano
 = dimensions with lever
 for hand release
 = Abmessungen mit Hebel
 für Nothandlüftung

G-400 T2 senza ventilatori / Without cooling fans

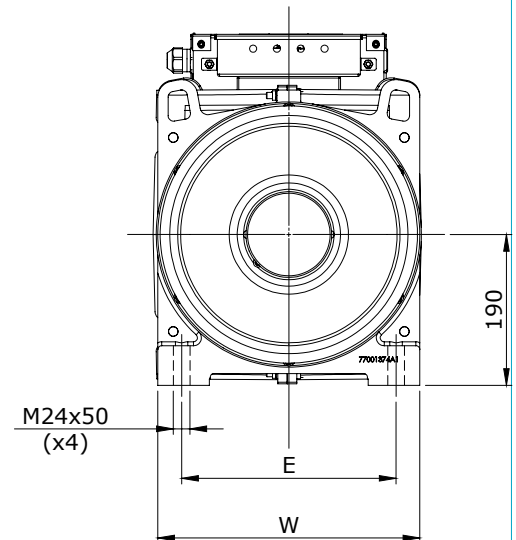
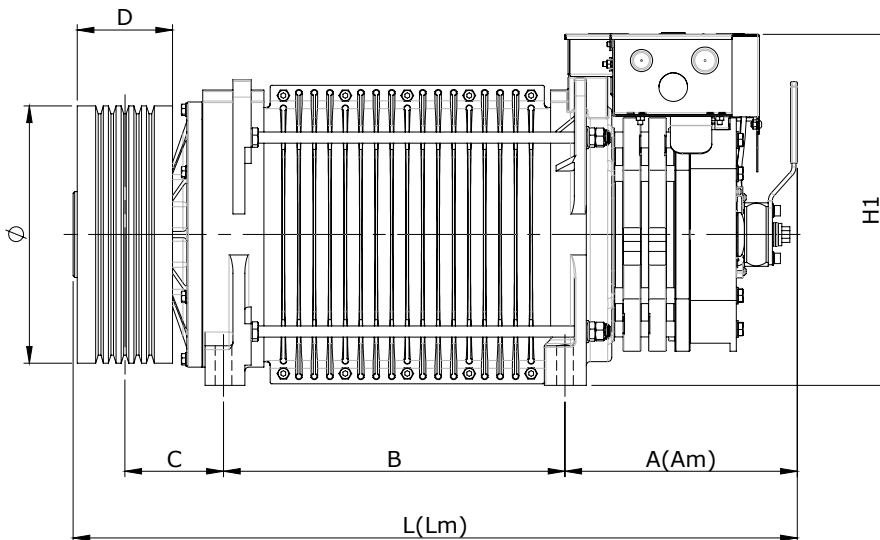



G-400 T3 Con ventilatori / with cooling fans

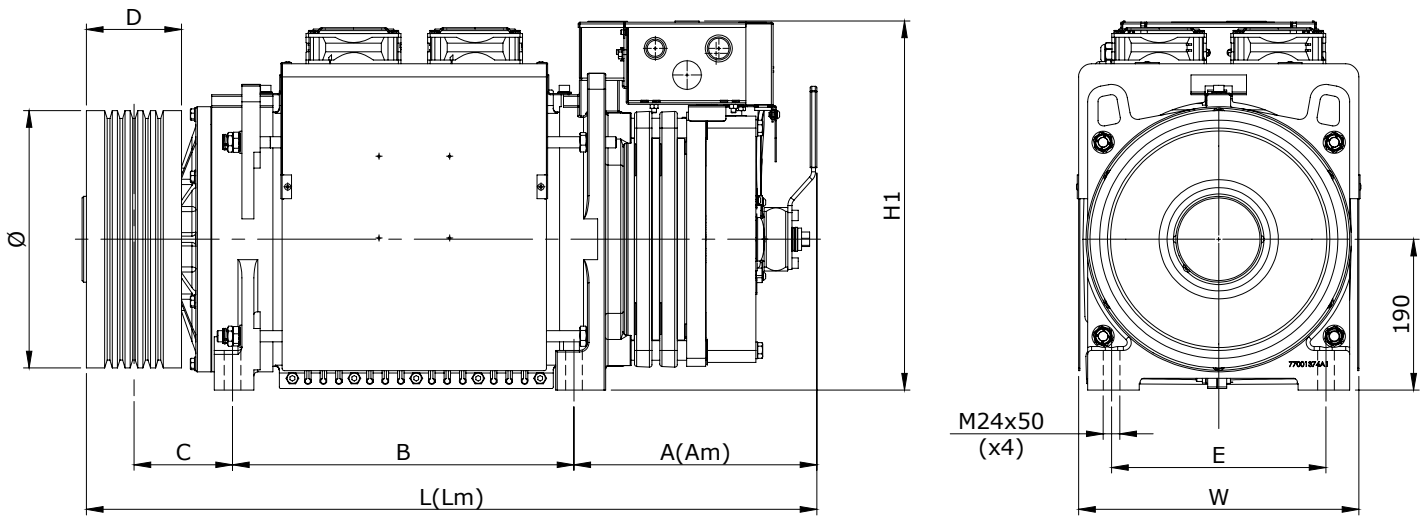

TIPO/TYPE G-400 T3	A	L	Am	Lm	B	C	E	W	H1	D	Ø
con carter ventilazione with cooling fans	279	897	324	942	430	124	270	356	465	120*	240 - 320 - 360 - 400 450 - 480 - 520 - 560 - 600 - 650
		927		972		139				150	240 - 320 - 360 - 400

Freno/ Brake DQ03

* Ø > 400 mm: pulegge con flangia e "D" = 115 mm
 Ø > 400 mm: flanged traction sheave with "D" = 115 mm





G-400 T1 IP66 Senza ventilatori / Without cooling fans *



Water & dust

* configurazione solo senza ventilatore né leve del freno / only configuration without neither fan nor brake levers.

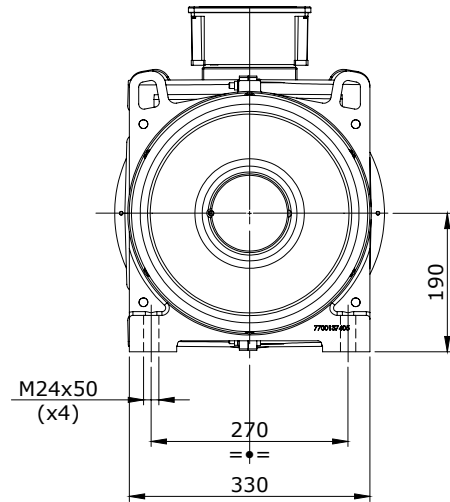
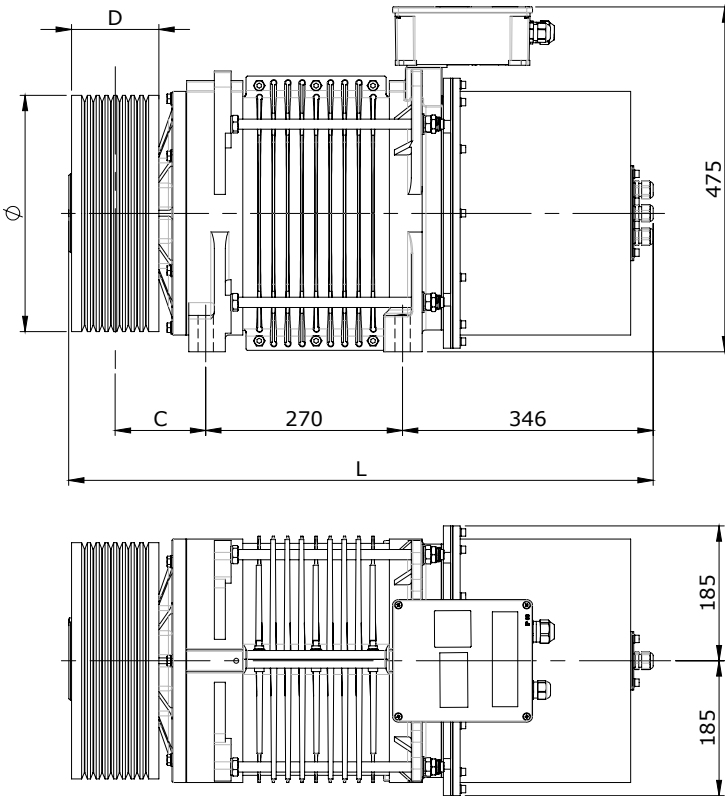

G-400 T2 IP66 Senza ventilatori / Without cooling fans *



Water & dust

* configurazione solo senza ventilatore né leve del freno / only configuration without neither fan nor brake levers.

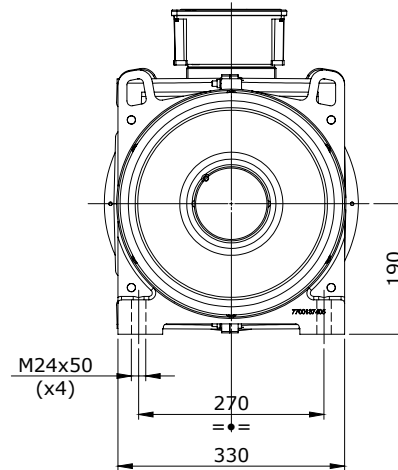
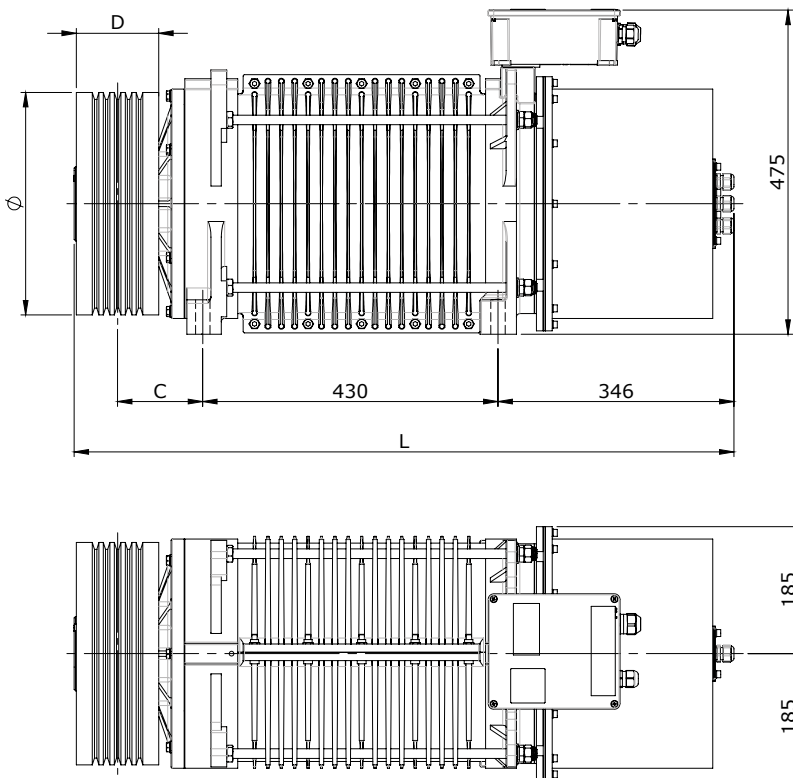

TYPE	L	C	D	Ø
G-400 T1	800	124	120	210 - 240 - 320 - 360 - 400 450 - 480 - 520 - 560 - 600
	830	139	150	240 - 320 - 360 - 400
G-400 T2	960	124	120	210 - 240 - 320 - 360 400 - 450 - 480 520 - 560 - 600 - 650
	990	139	150	240 - 320 - 360 - 400



G-400 T1 Con ventilatore speciale / With special cooling fan *

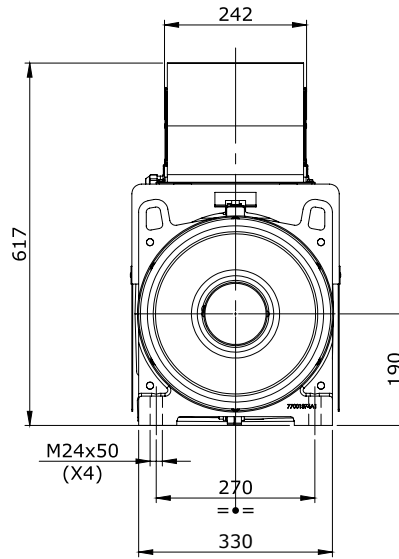
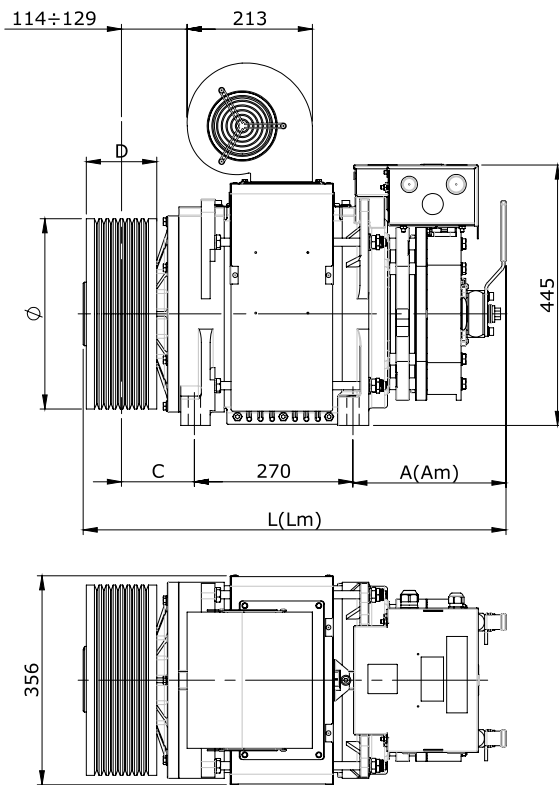

* Per un maggiore ciclo di lavoro rispetto allo standard.
Chiedere all'ufficio commerciale per maggiori informazioni
*For increased duty-cycle than the standard.
Ask the Sales dept. for more information.*

G-400 T2 • T3 Con ventilatore speciale / With special cooling fan *

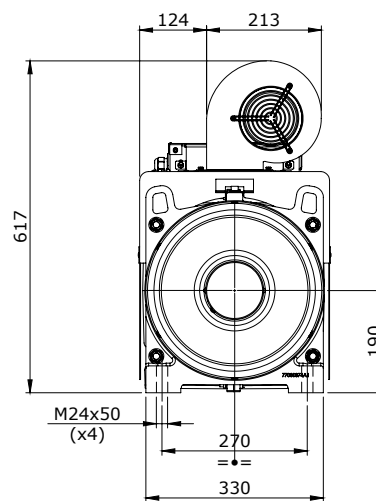
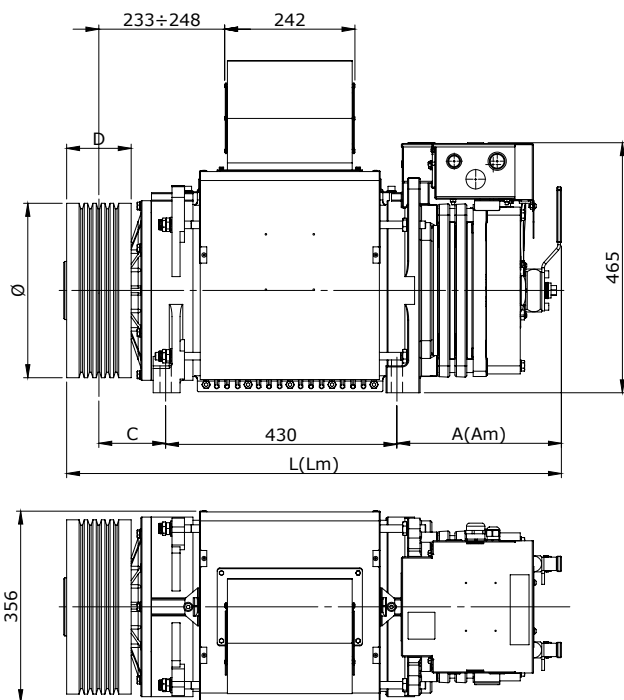

Am | **Lm**
= quote con manovra apertura a mano
= dimensions with lever for hand release
= Abmessungen mit Hebel für Nothandlüftung

TIPO/TYPE	A	L	Am	Lm	C	D	Ø
G-400 T1	215	670	260	715	124	120	210 - 240 - 320 - 360 - 400 - 450 - 480 - 520 - 560 - 600
		700		745	139	150	240 - 320 - 360 - 400
G-400 T2	247	862	292	907	124	120	210 - 240 - 320 - 360 - 400 - 450 - 480 - 520 - 560 - 600 - 650
		892		937	139	150	240 - 320 - 360 - 400
G-400 T3 Freno DQ03 Brake DQ03	279	897	324	942	124	120	210 - 240 - 320 - 360 - 400 - 450 - 480 - 520 - 560 - 600 - 650
		927		972	139	150	240 - 320 - 360 - 400



Tiro	Peso funi max	Portata	Velocità cabina	Ø Puleggia	Poli	Velocità	Frequenza	Efficienza vano	Coppia	Potenza in uscita
Roping Factor	Max Ropes Weight [kg]	Duty Load [kg]	Cabin Speed [m/s]	Sheave Diameter [mm]	Poles	Speed [rpm]	Frequency [Hz]	Shaft Efficiency	Torque [Nm]	Power Output [kW]
	(1)			(2) (3)			(4)	(5)		
1	30	400	0,63	210	16	57,3	7,64	0,85	279	1,7
1	30	400	0,63	240	16	50,1	6,68	0,85	319	1,7
1	30	400	0,63	320	16	37,6	5,01	0,85	425	1,7
1	30	400	0,63	360	16	33,4	4,46	0,85	478	1,7
1	30	400	0,63	400	16	30,1	4,01	0,85	531	1,7
1	30	400	0,63	450	16	26,7	3,57	0,85	597	1,7
1	30	400	0,63	480	16	25,1	3,34	0,85	637	1,7
1	30	400	1	210	16	90,9	12,13	0,85	279	2,7
1	30	400	1	240	16	79,6	10,61	0,85	319	2,7
1	30	400	1	320	16	59,7	7,96	0,85	425	2,7
1	30	400	1	360	16	53,1	7,07	0,85	478	2,7
1	30	400	1	400	16	47,7	6,37	0,85	531	2,7
1	30	400	1	450	16	42,4	5,66	0,85	597	2,7
1	30	400	1	480	16	39,8	5,31	0,85	637	2,7
1	30	400	1,6	210	16	145,5	19,40	0,85	279	4,2
1	30	400	1,6	240	16	127,3	16,98	0,85	319	4,2
1	30	400	1,6	320	16	95,5	12,73	0,85	425	4,2
1	30	400	1,6	360	16	84,9	11,32	0,85	478	4,2
1	30	400	1,6	400	16	76,4	10,19	0,85	531	4,2
1	30	400	1,6	450	16	67,9	9,05	0,85	597	4,2
1	30	400	1,6	480	16	63,7	8,49	0,85	637	4,2
1	30	400	2,5	210	16	227,4	30,32	0,85	279	6,6
1	30	400	2,5	240	16	198,9	26,53	0,85	319	6,6
1	30	400	2,5	320	16	149,2	19,89	0,85	425	6,6
1	30	400	2,5	360	16	132,6	17,68	0,85	478	6,6
1	30	400	2,5	400	16	119,4	15,92	0,85	531	6,6
1	30	400	2,5	450	16	106,1	14,15	0,85	597	6,6
1	30	400	2,5	480	16	99,5	13,26	0,85	637	6,6
1	30	480	0,63	210	16	57,3	7,64	0,85	327	2,0
1	30	480	0,63	240	16	50,1	6,68	0,85	374	2,0
1	30	480	0,63	320	16	37,6	5,01	0,85	499	2,0
1	30	480	0,63	360	16	33,4	4,46	0,85	561	2,0
1	30	480	0,63	400	16	30,1	4,01	0,85	623	2,0
1	30	480	1	210	16	90,9	12,13	0,85	327	3,1
1	30	480	1	240	16	79,6	10,61	0,85	374	3,1
1	30	480	1	320	16	59,7	7,96	0,85	499	3,1
1	30	480	1	360	16	53,1	7,07	0,85	561	3,1
1	30	480	1	400	16	47,7	6,37	0,85	623	3,1
1	30	480	1,6	210	16	145,5	19,40	0,85	327	5,0
1	30	480	1,6	240	16	127,3	16,98	0,85	374	5,0
1	30	480	1,6	320	16	95,5	12,73	0,85	499	5,0
1	30	480	1,6	360	16	84,9	11,32	0,85	561	5,0
1	30	480	1,6	400	16	76,4	10,19	0,85	623	5,0
1	30	480	2,5	210	16	227,4	30,32	0,85	327	7,8
1	30	480	2,5	240	16	198,9	26,53	0,85	374	7,8
1	30	480	2,5	320	16	149,2	19,89	0,85	499	7,8
1	30	480	2,5	360	16	132,6	17,68	0,85	561	7,8
1	30	480	2,5	400	16	119,4	15,92	0,85	623	7,8
1	30	630	0,63	210	16	57,3	7,64	0,85	418	2,5
1	30	630	0,63	240	16	50,1	6,68	0,85	478	2,5
1	30	630	0,63	320	16	37,6	5,01	0,85	637	2,5
1	30	630	1	210	16	90,9	12,13	0,85	418	4,0
1	30	630	1	240	16	79,6	10,61	0,85	478	4,0
1	30	630	1	320	16	59,7	7,96	0,85	637	4,0
1	30	630	1,6	210	16	145,5	19,40	0,85	418	6,4
1	30	630	1,6	240	16	127,3	16,98	0,85	478	6,4
1	30	630	1,6	320	16	95,5	12,73	0,85	637	6,4

G-400 T1 Gearless



Tiro <i>Roping Factor</i>	Peso funi max <i>Max Ropes Weight [kg]</i>	Portata <i>Duty Load [kg]</i>	Velocità cabina <i>Cabin Speed [m/s]</i>	Ø Puleggia <i>Sheave Diameter [mm]</i>	Poli <i>Poles</i>	Velocità <i>Speed [rpm]</i>	Frequenza <i>Frequency [Hz]</i>	Efficienza vano <i>Shaft Efficiency</i>	Coppia <i>Torque [Nm]</i>	Potenza in uscita <i>Power Output [kW]</i>
	(1)			(2) (3)			(4)	(5)		
1	30	630	2,5	210	16	227,4	30,32	0,85	418	10,0
1	30	630	2,5	240	16	198,9	26,53	0,85	478	10,0
1	30	630	2,5	320	16	149,2	19,89	0,85	637	10,0
1	30	750	0,63	210	16	57,3	7,64	0,85	491	2,9
1	30	750	0,63	240	16	50,1	6,68	0,85	561	2,9
1	30	750	1	210	16	90,9	12,13	0,85	491	4,7
1	30	750	1	240	16	79,6	10,61	0,85	561	4,7
1	30	750	1,6	210	16	145,5	19,40	0,85	491	7,5
1	30	750	1,6	240	16	127,3	16,98	0,85	561	7,5
1	30	750	2,5	210	16	227,4	30,32	0,85	491	11,7
1	30	750	2,5	240	16	198,9	26,53	0,85	561	11,7
1	30	800	0,63	240	16	50,1	6,68	0,85	596	3,1
1	30	800	1	240	16	79,6	10,61	0,85	596	5,0
1	30	800	1,6	240	16	127,3	16,98	0,85	596	7,9
1	30	800	2,5	240	16	198,9	26,53	0,85	596	12,4
2	30	480	0,63	210	16	114,6	15,28	0,85	182	2,2
2	30	480	0,63	240	16	100,3	13,37	0,85	208	2,2
2	30	480	0,63	320	16	75,2	10,03	0,85	277	2,2
2	30	480	0,63	360	16	66,8	8,91	0,85	312	2,2
2	30	480	0,63	400	16	60,2	8,02	0,85	346	2,2
2	30	480	0,63	450	16	53,5	7,13	0,85	390	2,2
2	30	480	0,63	480	16	50,1	6,68	0,85	415	2,2
2	30	480	0,63	520	16	46,3	6,17	0,85	450	2,2
2	30	480	0,63	560	16	43,0	5,73	0,85	485	2,2
2	30	480	0,63	600	16	40,1	5,35	0,85	519	2,2
2	30	480	1	210	16	181,9	24,25	0,85	182	3,5
2	30	480	1	240	16	159,2	21,22	0,85	208	3,5
2	30	480	1	320	16	119,4	15,92	0,85	277	3,5
2	30	480	1	360	16	106,1	14,15	0,85	312	3,5
2	30	480	1	400	16	95,5	12,73	0,85	346	3,5
2	30	480	1	450	16	84,9	11,32	0,85	390	3,5
2	30	480	1	480	16	79,6	10,61	0,85	415	3,5
2	30	480	1	520	16	73,5	9,79	0,85	450	3,5
2	30	480	1	560	16	68,2	9,09	0,85	485	3,5
2	30	480	1	600	16	63,7	8,49	0,85	519	3,5
2	30	480	1,6	210	16	291,0	38,80	0,85	182	5,5
2	30	480	1,6	240	16	254,6	33,95	0,85	208	5,5
2	30	480	1,6	320	16	191,0	25,46	0,85	277	5,5
2	30	480	1,6	360	16	169,8	22,64	0,85	312	5,5
2	30	480	1,6	400	16	152,8	20,37	0,85	346	5,5
2	30	480	1,6	450	16	135,8	18,11	0,85	390	5,5
2	30	480	1,6	480	16	127,3	16,98	0,85	415	5,5
2	30	480	1,6	520	16	117,5	15,67	0,85	450	5,5
2	30	480	1,6	560	16	109,1	14,55	0,85	485	5,5
2	30	480	1,6	600	16	101,9	13,58	0,85	519	5,5
2	30	480	2,5	320	16	298,4	39,79	0,85	277	8,7
2	30	480	2,5	360	16	265,3	35,37	0,85	312	8,7
2	30	480	2,5	400	16	238,7	31,83	0,85	346	8,7
2	30	480	2,5	450	16	212,2	28,29	0,85	390	8,7
2	30	480	2,5	480	16	198,9	26,53	0,85	415	8,7
2	30	480	2,5	520	16	183,6	24,49	0,85	450	8,7
2	30	480	2,5	560	16	170,5	22,74	0,85	485	8,7
2	30	480	2,5	600	16	159,2	21,22	0,85	519	8,7
2	30	630	0,63	210	16	114,6	15,28	0,85	227	2,7
2	30	630	0,63	240	16	100,3	13,37	0,85	260	2,7
2	30	630	0,63	320	16	75,2	10,03	0,85	346	2,7
2	30	630	0,63	360	16	66,8	8,91	0,85	390	2,7



Tiro	Peso funi max	Portata	Velocità cabina	Ø Puleggia	Poli	Velocità	Frequenza	Efficienza vano	Coppia	Potenza in uscita
Roping Factor	Max Ropes Weight [kg]	Duty Load [kg]	Cabin Speed [m/s]	Sheave Diameter [mm]	Poles	Speed [rpm]	Frequency [Hz]	Shaft Efficiency	Torque [Nm]	Power Output [kW]
	(1)			(2) (3)			(4)	(5)		
2	30	630	0,63	400	16	60,2	8,02	0,85	433	2,7
2	30	630	0,63	450	16	53,5	7,13	0,85	487	2,7
2	30	630	0,63	480	16	50,1	6,68	0,85	519	2,7
2	30	630	0,63	520	16	46,3	6,17	0,85	563	2,7
2	30	630	0,63	560	16	43,0	5,73	0,85	606	2,7
2	30	630	1	210	16	181,9	24,25	0,85	227	4,3
2	30	630	1	240	16	159,2	21,22	0,85	260	4,3
2	30	630	1	320	16	119,4	15,92	0,85	346	4,3
2	30	630	1	360	16	106,1	14,15	0,85	390	4,3
2	30	630	1	400	16	95,5	12,73	0,85	433	4,3
2	30	630	1	450	16	84,9	11,32	0,85	487	4,3
2	30	630	1	480	16	79,6	10,61	0,85	519	4,3
2	30	630	1	520	16	73,5	9,79	0,85	563	4,3
2	30	630	1	560	16	68,2	9,09	0,85	606	4,3
2	30	630	1,6	210	16	291,0	38,80	0,85	227	6,9
2	30	630	1,6	240	16	254,6	33,95	0,85	260	6,9
2	30	630	1,6	320	16	191,0	25,46	0,85	346	6,9
2	30	630	1,6	360	16	169,8	22,64	0,85	390	6,9
2	30	630	1,6	400	16	152,8	20,37	0,85	433	6,9
2	30	630	1,6	450	16	135,8	18,11	0,85	487	6,9
2	30	630	1,6	480	16	127,3	16,98	0,85	519	6,9
2	30	630	1,6	520	16	117,5	15,67	0,85	563	6,9
2	30	630	1,6	560	16	109,1	14,55	0,85	606	6,9
2	30	630	2,5	320	16	298,4	39,79	0,85	346	10,8
2	30	630	2,5	360	16	265,3	35,37	0,85	390	10,8
2	30	630	2,5	400	16	238,7	31,83	0,85	433	10,8
2	30	630	2,5	450	16	212,2	28,29	0,85	487	10,8
2	30	630	2,5	480	16	198,9	26,53	0,85	519	10,8
2	30	630	2,5	520	16	183,6	24,49	0,85	563	10,8
2	30	630	2,5	560	16	170,5	22,74	0,85	606	10,8
2	30	800	0,63	210	16	114,6	15,28	0,85	279	3,3
2	30	800	0,63	240	16	100,3	13,37	0,85	319	3,3
2	30	800	0,63	320	16	75,2	10,03	0,85	425	3,3
2	30	800	0,63	360	16	66,8	8,91	0,85	478	3,3
2	30	800	0,63	400	16	60,2	8,02	0,85	531	3,3
2	30	800	0,63	450	16	53,5	7,13	0,85	597	3,3
2	30	800	0,63	480	16	50,1	6,68	0,85	637	3,3
2	30	800	1	210	16	181,9	24,25	0,85	279	5,3
2	30	800	1	240	16	159,2	21,22	0,85	319	5,3
2	30	800	1	320	16	119,4	15,92	0,85	425	5,3
2	30	800	1	360	16	106,1	14,15	0,85	478	5,3
2	30	800	1	400	16	95,5	12,73	0,85	531	5,3
2	30	800	1	450	16	84,9	11,32	0,85	597	5,3
2	30	800	1	480	16	79,6	10,61	0,85	637	5,3
2	30	800	1,6	210	16	291,0	38,80	0,85	279	8,5
2	30	800	1,6	240	16	254,6	33,95	0,85	319	8,5
2	30	800	1,6	320	16	191,0	25,46	0,85	425	8,5
2	30	800	1,6	360	16	169,8	22,64	0,85	478	8,5
2	30	800	1,6	400	16	152,8	20,37	0,85	531	8,5
2	30	800	1,6	450	16	135,8	18,11	0,85	597	8,5
2	30	800	1,6	480	16	127,3	16,98	0,85	637	8,5
2	30	800	2,5	320	16	298,4	39,79	0,85	425	13,3
2	30	800	2,5	360	16	265,3	35,37	0,85	478	13,3
2	30	800	2,5	400	16	238,7	31,83	0,85	531	13,3
2	30	800	2,5	450	16	212,2	28,29	0,85	597	13,3
2	30	800	2,5	480	16	198,9	26,53	0,85	637	13,3
2	30	1000	0,63	210	16	114,6	15,28	0,85	339	4,1
2	30	1000	0,63	240	16	100,3	13,37	0,85	388	4,1
2	30	1000	0,63	320	16	75,2	10,03	0,85	517	4,1
2	30	1000	0,63	360	16	66,8	8,91	0,85	582	4,1



Tiro <i>Roping Factor</i>	Peso funi max <i>Max Ropes Weight [kg]</i>	Portata <i>Duty Load [kg]</i>	Velocità cabina <i>Cabin Speed [m/s]</i>	Ø Puleggia <i>Sheave Diameter [mm]</i>	Poli <i>Poles</i>	Velocità <i>Speed [rpm]</i>	Frequenza <i>Frequency [Hz]</i>	Efficienza vano <i>Shaft Efficiency</i>	Coppia <i>Torque [Nm]</i>	Potenza in uscita <i>Power Output [kW]</i>
	(1)			(2) (3)			(4)	(5)		
2	30	1000	1	210	16	181,9	24,25	0,85	339	6,5
2	30	1000	1	240	16	159,2	21,22	0,85	388	6,5
2	30	1000	1	320	16	119,4	15,92	0,85	517	6,5
2	30	1000	1	360	16	106,1	14,15	0,85	582	6,5
2	30	1000	1,6	210	16	291,0	38,80	0,85	339	10,3
2	30	1000	1,6	240	16	254,6	33,95	0,85	388	10,3
2	30	1000	1,6	320	16	191,0	25,46	0,85	517	10,3
2	30	1000	1,6	360	16	169,8	22,64	0,85	582	10,3
2	30	1000	2,5	320	16	298,4	39,79	0,85	517	16,2
2	30	1000	2,5	360	16	265,3	35,37	0,85	582	16,2
2	30	1125	0,63	210	16	114,6	15,28	0,85	377	4,5
2	30	1125	0,63	240	16	100,3	13,37	0,85	431	4,5
2	30	1125	0,63	320	16	75,2	10,03	0,85	575	4,5
2	30	1125	1	210	16	181,9	24,25	0,85	377	7,2
2	30	1125	1	240	16	159,2	21,22	0,85	431	7,2
2	30	1125	1	320	16	119,4	15,92	0,85	575	7,2
2	30	1125	1,6	210	16	291,0	38,80	0,85	377	11,5
2	30	1125	1,6	240	16	254,6	33,95	0,85	431	11,5
2	30	1125	1,6	320	16	191,0	25,46	0,85	575	11,5
2	30	1125	2	240	16	318,3	42,44	0,85	431	14,4
2	30	1125	2	320	16	238,7	31,83	0,85	575	14,4
2	30	1125	2,5	320	16	298,4	39,79	0,85	575	18,0
2	30	1250	0,63	210	16	114,6	15,28	0,85	415	5,0
2	30	1250	0,63	240	16	100,3	13,37	0,85	474	5,0
2	30	1250	0,63	320	16	75,2	10,03	0,85	632	5,0
2	30	1250	1	210	16	181,9	24,25	0,85	415	7,9
2	30	1250	1	240	16	159,2	21,22	0,85	474	7,9
2	30	1250	1	320	16	119,4	15,92	0,85	632	7,9
2	30	1250	1,6	210	16	291,0	38,80	0,85	415	12,6
2	30	1250	1,6	240	16	254,6	33,95	0,85	474	12,6
2	30	1250	1,6	320	16	191,0	25,46	0,85	632	12,6
2	30	1250	2	240	16	318,3	42,44	0,85	474	15,8
2	30	1250	2	320	16	238,7	31,83	0,85	632	15,8
2	30	1250	2,5	320	16	298,4	39,79	0,85	632	19,8

C_Max [Nm] = 640

G-400 T1 - NOTE

Brake Type: DF02 - Standard 205 V DC - Other voltages on request.

Static Load: 3500 kg.

Encoder Type: Absolute encoder with EnDat Interface or Incremental sin/cos, both with 2048 ppr;

Note 1: For higher ropes weight, please consult sales/technical services of Alberto Sassi SpA.

Note 2: Details on ropes/grooves provided upon lift data.

Note 3: Suitable for steel core ropes or also for plastic coated ropes.

Note 4: For frequencies lower than 5 Hz, please consult your inverter supplier.

Note 5: Shaft efficiency includes divertor pulleys efficiency by considering: 3 divertors for roping 2:1. Values are supposed.

Note 6: Max 240 sts/h - 40% ED without fans.
Max 240 sts/h - 50% ED with fans activated by thermocontacts inside motor.

Note 7: DFX certified brake against Overspeed in upward direction and as UCM (EN 81-20:2014, EN 81-50:2014) with reference to Lift Directive 2014/33/EU.

Note 8: Traction sheave length: 120 mm. Available length 150 mm for Ø240, Ø320, Ø360 and Ø400.

Note 9: Weight 245 kg.

The Alberto Sassi SpA reserves the rights to change data and features without previous notice.



Tiro	Peso funi max	Portata	Velocità cabina	Ø Puleggia	Poli	Velocità	Frequenza	Efficienza vano	Coppia	Potenza in uscita
Roping Factor	Max Ropes Weight [kg]	Duty Load [kg]	Cabin Speed [m/s]	Sheave Diameter [mm]	Poles	Speed [rpm]	Frequency [Hz]	Shaft Efficiency	Torque [Nm]	Power Output [kW]
	(1)			(2) (3)			(4)	(5)		
1	50	480	0,63	450	16	26,7	3,57	0,85	753	2,1
1	50	480	0,63	480	16	25,1	3,34	0,85	803	2,1
1	50	480	0,63	520	16	23,1	3,09	0,85	870	2,1
1	50	480	0,63	560	16	21,5	2,86	0,85	937	2,1
1	50	480	0,63	600	16	20,1	2,67	0,85	1004	2,1
1	50	480	1	450	16	42,4	5,66	0,85	753	3,3
1	50	480	1	480	16	39,8	5,31	0,85	803	3,3
1	50	480	1	520	16	36,7	4,90	0,85	870	3,3
1	50	480	1	560	16	34,1	4,55	0,85	937	3,3
1	50	480	1	600	16	31,8	4,24	0,85	1004	3,3
1	50	480	1,6	450	16	67,9	9,05	0,85	753	5,4
1	50	480	1,6	480	16	63,7	8,49	0,85	803	5,4
1	50	480	1,6	520	16	58,8	7,84	0,85	870	5,4
1	50	480	1,6	560	16	54,6	7,28	0,85	937	5,4
1	50	480	1,6	600	16	50,9	6,79	0,85	1004	5,4
1	50	480	2,5	450	16	106,1	14,15	0,85	753	8,4
1	50	480	2,5	480	16	99,5	13,26	0,85	803	8,4
1	50	480	2,5	520	16	91,8	12,24	0,85	870	8,4
1	50	480	2,5	560	16	85,3	11,37	0,85	937	8,4
1	50	480	2,5	600	16	79,6	10,61	0,85	1004	8,4
1	50	630	0,63	360	16	33,4	4,46	0,85	758	2,7
1	50	630	0,63	400	16	30,1	4,01	0,85	843	2,7
1	50	630	0,63	450	16	26,7	3,57	0,85	948	2,7
1	50	630	0,63	480	16	25,1	3,34	0,85	1011	2,7
1	50	630	1	360	16	53,1	7,07	0,85	758	4,2
1	50	630	1	400	16	47,7	6,37	0,85	843	4,2
1	50	630	1	450	16	42,4	5,66	0,85	948	4,2
1	50	630	1	480	16	39,8	5,31	0,85	1011	4,2
1	50	630	1,6	360	16	84,9	11,32	0,85	758	6,7
1	50	630	1,6	400	16	76,4	10,19	0,85	843	6,7
1	50	630	1,6	450	16	67,9	9,05	0,85	948	6,7
1	50	630	1,6	480	16	63,7	8,49	0,85	1011	6,7
1	50	630	2,5	360	16	132,6	17,68	0,85	758	10,5
1	50	630	2,5	400	16	119,4	15,92	0,85	843	10,5
1	50	630	2,5	450	16	106,1	14,15	0,85	948	10,5
1	50	630	2,5	480	16	99,5	13,26	0,85	1011	10,5
1	50	800	0,63	320	16	37,6	5,01	0,85	831	3,3
1	50	800	0,63	360	16	33,4	4,46	0,85	935	3,3
1	50	800	1	320	16	59,7	7,96	0,85	831	5,2
1	50	800	1	360	16	53,1	7,07	0,85	935	5,2
1	50	800	1,6	320	16	95,5	12,73	0,85	831	8,3
1	50	800	1,6	360	16	84,9	11,32	0,85	935	8,3
1	50	800	2,5	320	16	149,2	19,89	0,85	831	13,0
1	50	800	2,5	360	16	132,6	17,68	0,85	935	13,0
1	50	1000	0,63	210	16	57,3	7,64	0,85	667	4,0
1	50	1000	0,63	240	16	50,1	6,68	0,85	762	4,0
1	50	1000	0,63	320	16	37,6	5,01	0,85	1016	4,0
1	50	1000	1	210	16	90,9	12,13	0,85	667	6,3
1	50	1000	1	240	16	79,6	10,61	0,85	762	6,3
1	50	1000	1	320	16	59,7	7,96	0,85	1016	6,3
1	50	1000	1,6	210	16	145,5	19,40	0,85	667	10,2
1	50	1000	1,6	240	16	127,3	16,98	0,85	762	10,2

G-400 T2 Gearless



Tiro	Peso funi max	Portata	Velocità cabina	Ø Puleggia	Poli	Velocità	Frequenza	Efficienza vano	Coppia	Potenza in uscita
Roping Factor	Max Ropes Weight [kg]	Duty Load [kg]	Cabin Speed [m/s]	Sheave Diameter [mm]	Poles	Speed [rpm]	Frequency [Hz]	Shaft Efficiency	Torque [Nm]	Power Output [kW]
	(1)			(2) (3)			(4)	(5)		
1	50	1000	1,6	320	16	95,5	12,73	0,85	1016	10,2
1	50	1000	2,5	210	16	227,4	30,32	0,85	667	15,9
1	50	1000	2,5	240	16	198,9	26,53	0,85	762	15,9
1	50	1000	2,5	320	16	149,2	19,89	0,85	1016	15,9
2	50	1000	0,63	400	16	60,2	8,02	0,85	692	4,4
2	50	1000	0,63	450	16	53,5	7,13	0,85	779	4,4
2	50	1000	0,63	480	16	50,1	6,68	0,85	831	4,4
2	50	1000	0,63	520	16	46,3	6,17	0,85	900	4,4
2	50	1000	0,63	560	16	43,0	5,73	0,85	969	4,4
2	50	1000	1	400	16	95,5	12,73	0,85	692	6,9
2	50	1000	1	450	16	84,9	11,32	0,85	779	6,9
2	50	1000	1	480	16	79,6	10,61	0,85	831	6,9
2	50	1000	1	520	16	73,5	9,79	0,85	900	6,9
2	50	1000	1	560	16	68,2	9,09	0,85	969	6,9
2	50	1000	1,6	400	16	152,8	20,37	0,85	692	11,1
2	50	1000	1,6	450	16	135,8	18,11	0,85	779	11,1
2	50	1000	1,6	480	16	127,3	16,98	0,85	831	11,1
2	50	1000	1,6	520	16	117,5	15,67	0,85	900	11,1
2	50	1000	1,6	560	16	109,1	14,55	0,85	969	11,1
2	50	1000	2,5	400	16	238,7	31,83	0,85	692	17,3
2	50	1000	2,5	450	16	212,2	28,29	0,85	779	17,3
2	50	1000	2,5	480	16	198,9	26,53	0,85	831	17,3
2	50	1000	2,5	520	16	183,6	24,49	0,85	900	17,3
2	50	1000	2,5	560	16	170,5	22,74	0,85	969	17,3
2	50	1250	0,63	210	16	114,6	15,28	0,85	439	5,3
2	50	1250	0,63	240	16	100,3	13,37	0,85	502	5,3
2	50	1250	0,63	320	16	75,2	10,03	0,85	669	5,3
2	50	1250	0,63	360	16	66,8	8,91	0,85	753	5,3
2	50	1250	0,63	400	16	60,2	8,02	0,85	837	5,3
2	50	1250	0,63	450	16	53,5	7,13	0,85	941	5,3
2	50	1250	0,63	480	16	50,1	6,68	0,85	1004	5,3
2	50	1250	1	210	16	181,9	24,25	0,85	439	8,4
2	50	1250	1	240	16	159,2	21,22	0,85	502	8,4
2	50	1250	1	320	16	119,4	15,92	0,85	669	8,4
2	50	1250	1	360	16	106,1	14,15	0,85	753	8,4
2	50	1250	1	400	16	95,5	12,73	0,85	837	8,4
2	50	1250	1	450	16	84,9	11,32	0,85	941	8,4
2	50	1250	1	480	16	79,6	10,61	0,85	1004	8,4
2	50	1250	1,6	210	16	291,0	38,80	0,85	439	13,4
2	50	1250	1,6	240	16	254,6	33,95	0,85	502	13,4
2	50	1250	1,6	320	16	191,0	25,46	0,85	669	13,4
2	50	1250	1,6	360	16	169,8	22,64	0,85	753	13,4
2	50	1250	1,6	400	16	152,8	20,37	0,85	837	13,4
2	50	1250	1,6	450	16	135,8	18,11	0,85	941	13,4
2	50	1250	1,6	480	16	127,3	16,98	0,85	1004	13,4
2	50	1250	2,5	320	16	298,4	39,79	0,85	669	20,9
2	50	1250	2,5	360	16	265,3	35,37	0,85	753	20,9
2	50	1250	2,5	400	16	238,7	31,83	0,85	837	20,9
2	50	1250	2,5	450	16	212,2	28,29	0,85	941	20,9
2	50	1250	2,5	480	16	198,9	26,53	0,85	1004	20,9
2	50	1600	0,63	210	16	114,6	15,28	0,85	545	6,5
2	50	1600	0,63	240	16	100,3	13,37	0,85	623	6,5



Tiro <i>Roping Factor</i>	Peso funi max <i>Max Ropes Weight [kg]</i>	Portata <i>Duty Load [kg]</i>	Velocità cabina <i>Cabin Speed [m/s]</i>	Ø Puleggia <i>Sheave Diameter [mm]</i>	Poli <i>Poles</i>	Velocità <i>Speed [rpm]</i>	Frequenza <i>Frequency [Hz]</i>	Efficienza vano <i>Shaft Efficiency</i>	Coppia <i>Torque [Nm]</i>	Potenza in uscita <i>Power Output [kW]</i>
	(1)			(2) (3)			(4)	(5)		
2	50	1600	0,63	320	16	75,2	10,03	0,85	831	6,5
2	50	1600	0,63	360	16	66,8	8,91	0,85	935	6,5
2	50	1600	1	210	16	181,9	24,25	0,85	545	10,4
2	50	1600	1	240	16	159,2	21,22	0,85	623	10,4
2	50	1600	1	320	16	119,4	15,92	0,85	831	10,4
2	50	1600	1	360	16	106,1	14,15	0,85	935	10,4
2	50	1600	1,6	210	16	291,0	38,80	0,85	545	16,6
2	50	1600	1,6	240	16	254,6	33,95	0,85	623	16,6
2	50	1600	1,6	320	16	191,0	25,46	0,85	831	16,6
2	50	1600	1,6	360	16	169,8	22,64	0,85	935	16,6
2	50	1600	2	240	16	318,3	42,44	0,85	623	20,8
2	50	1600	2	320	16	238,7	31,83	0,85	831	20,8
2	50	1600	2	360	16	212,2	28,29	0,85	935	20,8
2	50	2000	0,63	240	16	100,3	13,37	0,85	762	8,0
2	50	2000	0,63	320	16	75,2	10,03	0,85	1016	8,0
2	50	2000	1	240	16	159,2	21,22	0,85	762	12,7
2	50	2000	1	320	16	119,4	15,92	0,85	1016	12,7
2	50	2000	1,6	240	16	254,6	33,95	0,85	762	20,3
2	50	2000	1,6	320	16	191,0	25,46	0,85	1016	20,3
2	50	2000	2	240	16	318,3	42,44	0,85	762	25,4
2	50	2000	2	320	16	238,7	31,83	0,85	1016	25,4

C_Max [Nm] = 1020**G-400 T2 - NOTE****Brake Type:** DF03 - Standard 205 V DC - Other voltages on request.**Static Load:** 4500 kg.**Encoder Type:** Absolute encoder with EnDat Interface or Incremental sin/cos, both with 2048 ppr;**Note 1:** For higher ropes weight, please consult sales/technical services of Alberto Sassi SpA.**Note 2:** Details on ropes/grooves provided upon lift data.**Note 3:** Suitable for steel core ropes or also for plastic coated ropes.**Note 4:** For frequencies lower than 5 Hz, please consult your inverter supplier**Note 5:** Shaft efficiency includes diverter pulleys efficiency by considering: 3 divertors for roping 2:1. Values are supposed.**Note 6:** Max 240 sts/h - 40% ED without fans.

Max 240 sts/h - 50% ED with fans activated by thermocontacts inside motor.

Note 7: DFX certified brake against Overspeed in upward direction and as UCM (EN 81-20:2014, EN 81-50:2014) with reference to Lift Directive 2014/33/EU.**Note 8:** Traction sheave length: 120 mm. Available length 150 mm for Ø240, Ø320, Ø360 and Ø400.**Note 9:** Weight 356 kg.*The Alberto Sassi SpA reserves the rights to change data and features without previous notice.*

G-400 T3 Gearless



Tiro	Peso funi max	Portata	Velocità cabina	Ø Puleggia	Poli	Velocità	Frequenza	Efficienza vano	Coppia	Potenza in uscita
Roping Factor	Max Ropes Weight [kg]	Duty Load [kg]	Cabin Speed [m/s]	Sheave Diameter [mm]	Poles	Speed [rpm]	Frequency [Hz]	Shaft Efficiency	Torque [Nm]	Power Output [kW]
	(1)			(2) (3)			(4)	(5)		
1	35	630	0,63	520	16	23,1	3,09	0,85	1050	2,5
1	35	630	0,63	560	16	21,5	2,86	0,85	1131	2,5
1	35	630	0,63	600	16	20,1	2,67	0,85	1212	2,5
1	35	630	1	520	16	36,7	4,90	0,85	1050	4,0
1	35	630	1	560	16	34,1	4,55	0,85	1131	4,0
1	35	630	1	600	16	31,8	4,24	0,85	1212	4,0
1	35	630	1,6	520	16	58,8	7,84	0,85	1050	6,5
1	35	630	1,6	560	16	54,6	7,28	0,85	1131	6,5
1	35	630	1,6	600	16	50,9	6,79	0,85	1212	6,5
1	35	630	2,5	520	16	91,8	12,24	0,85	1050	10,1
1	35	630	2,5	560	16	85,3	11,37	0,85	1131	10,1
1	35	630	2,5	600	16	79,6	10,61	0,85	1212	10,1
1	35	800	0,63	400	16	30,1	4,01	0,85	1004	3,2
1	35	800	0,63	450	16	26,7	3,57	0,85	1130	3,2
1	35	800	0,63	480	16	25,1	3,34	0,85	1205	3,2
1	35	800	1	400	16	47,7	6,37	0,85	1004	5,0
1	35	800	1	450	16	42,4	5,66	0,85	1130	5,0
1	35	800	1	480	16	39,8	5,31	0,85	1205	5,0
1	35	800	1,6	400	16	76,4	10,19	0,85	1004	8,0
1	35	800	1,6	450	16	67,9	9,05	0,85	1130	8,0
1	35	800	1,6	480	16	63,7	8,49	0,85	1205	8,0
1	35	800	2,5	400	16	119,4	15,92	0,85	1004	12,6
1	35	800	2,5	450	16	106,1	14,15	0,85	1130	12,6
1	35	800	2,5	480	16	99,5	13,26	0,85	1205	12,6
1	35	1000	0,63	320	16	37,6	5,01	0,85	988	3,9
1	35	1000	0,63	360	16	33,4	4,46	0,85	1111	3,9
1	35	1000	0,63	400	16	30,1	4,01	0,85	1235	3,9
1	35	1000	1	320	16	59,7	7,96	0,85	988	6,2
1	35	1000	1	360	16	53,1	7,07	0,85	1111	6,2
1	35	1000	1	400	16	47,7	6,37	0,85	1235	6,2
1	35	1000	1,6	320	16	95,5	12,73	0,85	988	9,9
1	35	1000	1,6	360	16	84,9	11,32	0,85	1111	9,9
1	35	1000	1,6	400	16	76,4	10,19	0,85	1235	9,9
1	35	1000	2,5	320	16	149,2	19,89	0,85	988	15,4
1	35	1000	2,5	360	16	132,6	17,68	0,85	1111	15,4
1	35	1000	2,5	400	16	119,4	15,92	0,85	1235	15,4
1	35	1250	0,63	320	16	37,6	5,01	0,85	1219	4,8
1	35	1250	1	320	16	59,7	7,96	0,85	1219	7,6
1	35	1250	1,6	320	16	95,5	12,73	0,85	1219	12,2
1	35	1250	2	320	16	119,4	15,92	0,85	1219	15,2
1	35	1250	2,5	320	16	149,2	19,89	0,85	1219	19,0
2	35	1000	0,63	600	16	40,1	5,35	0,85	987	4,1
2	35	1000	0,63	650	16	37,0	4,94	0,85	1069	4,1
2	35	1000	1	600	16	63,7	8,49	0,85	987	6,6
2	35	1000	1	650	16	58,8	7,84	0,85	1069	6,6
2	35	1000	1,6	600	16	101,9	13,58	0,85	987	10,5
2	35	1000	1,6	650	16	94,0	12,54	0,85	1069	10,5
2	35	1000	2,5	600	16	159,2	21,22	0,85	987	16,4
2	35	1000	2,5	650	16	146,9	19,59	0,85	1069	16,4
2	35	1250	0,63	480	16	50,1	6,68	0,85	963	5,1
2	35	1250	0,63	520	16	46,3	6,17	0,85	1043	5,1
2	35	1250	0,63	560	16	43,0	5,73	0,85	1123	5,1
2	35	1250	0,63	600	16	40,1	5,35	0,85	1203	5,1
2	35	1250	1	480	16	79,6	10,61	0,85	963	8,0



Tiro <i>Roping Factor</i>	Peso funi max <i>Max Ropes Weight [kg]</i>	Portata <i>Duty Load [kg]</i>	Velocità cabina <i>Cabin Speed [m/s]</i>	Ø Puleggia <i>Sheave Diameter [mm]</i>	Poli <i>Poles</i>	Velocità <i>Speed [rpm]</i>	Frequenza <i>Frequency [Hz]</i>	Efficienza vano <i>Shaft Efficiency</i>	Coppia <i>Torque [Nm]</i>	Potenza in uscita <i>Power Output [kW]</i>
	(1)			(2) (3)			(4)	(5)		
2	35	1250	1	520	16	73,5	9,79	0,85	1043	8,0
2	35	1250	1	560	16	68,2	9,09	0,85	1123	8,0
2	35	1250	1	600	16	63,7	8,49	0,85	1203	8,0
2	35	1250	1,6	480	16	127,3	16,98	0,85	963	12,8
2	35	1250	1,6	520	16	117,5	15,67	0,85	1043	12,8
2	35	1250	1,6	560	16	109,1	14,55	0,85	1123	12,8
2	35	1250	1,6	600	16	101,9	13,58	0,85	1203	12,8
2	35	1250	2,5	480	16	198,9	26,53	0,85	963	20,1
2	35	1250	2,5	520	16	183,6	24,49	0,85	1043	20,1
2	35	1250	2,5	560	16	170,5	22,74	0,85	1123	20,1
2	35	1250	2,5	600	16	159,2	21,22	0,85	1203	20,1
2	35	1600	0,63	360	16	66,8	8,91	0,85	904	6,3
2	35	1600	0,63	400	16	60,2	8,02	0,85	1004	6,3
2	35	1600	0,63	450	16	53,5	7,13	0,85	1130	6,3
2	35	1600	0,63	480	16	50,1	6,68	0,85	1205	6,3
2	35	1600	1	360	16	106,1	14,15	0,85	904	10,0
2	35	1600	1	400	16	95,5	12,73	0,85	1004	10,0
2	35	1600	1	450	16	84,9	11,32	0,85	1130	10,0
2	35	1600	1	480	16	79,6	10,61	0,85	1205	10,0
2	35	1600	1,6	360	16	169,8	22,64	0,85	904	16,1
2	35	1600	1,6	400	16	152,8	20,37	0,85	1004	16,1
2	35	1600	1,6	450	16	135,8	18,11	0,85	1130	16,1
2	35	1600	1,6	480	16	127,3	16,98	0,85	1205	16,1
2	35	1600	2,5	360	16	265,3	35,37	0,85	904	25,1
2	35	1600	2,5	400	16	238,7	31,83	0,85	1004	25,1
2	35	1600	2,5	450	16	212,2	28,29	0,85	1130	25,1
2	35	1600	2,5	480	16	198,9	26,53	0,85	1205	25,1
2	35	2000	0,63	320	16	75,2	10,03	0,85	988	7,8
2	35	2000	0,63	360	16	66,8	8,91	0,85	1111	7,8
2	35	2000	0,63	400	16	60,2	8,02	0,85	1235	7,8
2	35	2000	1	320	16	119,4	15,92	0,85	988	12,3
2	35	2000	1	360	16	106,1	14,15	0,85	1111	12,3
2	35	2000	1	400	16	95,5	12,73	0,85	1235	12,3
2	35	2000	1,6	320	16	191,0	25,46	0,85	988	19,8
2	35	2000	1,6	360	16	169,8	22,64	0,85	1111	19,8
2	35	2000	1,6	400	16	152,8	20,37	0,85	1235	19,8
2	35	2000	2,5	320	16	298,4	39,79	0,85	988	30,9
2	35	2000	2,5	360	16	265,3	35,37	0,85	1111	30,9
2	35	2000	2,5	400	16	238,7	31,83	0,85	1235	30,9

C_Max [Nm] = 1250

G-400 T3 - NOTE

Brake Type: DQ03 - Standard 205 V DC - Other voltages on request.

Static Load: 5200 kg.

Encoder Type: Absolute encoder with EnDat Interface or Incremental sin/cos, both with 2048 ppr;

Note 1: For higher ropes weight, please consult sales/technical services of Alberto Sassi SpA.

Note 2: Details on ropes/grooves provided upon lift data.

Note 3: Suitable for steel core ropes or also for plastic coated ropes.

Note 4: For frequencies lower than 5 Hz, please consult your inverter supplier.

Note 5: Shaft efficiency includes divertor pulleys efficiency by considering: 3 divertors for roping 2:1. Values are supposed.

Note 6: Max 180 sts/h - 40% ED with fans activated by thermocontacts inside motor.

Note 7: DQXY certified brake against Overspeed in upward direction and as UCM (EN 81-20:2014, EN 81-50:2014) with reference to Lift Directive 2014/33/EU.

Note 8: Traction sheave length: 120 mm. Available length 150 mm for Ø240, Ø320, Ø360 and Ø400.

Note 9: Weight 364 kg.

The Alberto Sassi SpA reserves the rights to change data and features without previous notice.



TIRO/ROPING 1/1 • Corsa/Travel 30 mt

Portata Duty loads [kg]	Velocità Speed [m/s]	Puleggia Sheave [mm]	* Combinazioni funi Ropes combination	N° Funi max, Installabile Max ropes nr.	Peso cabina Cabin Weight [kg]	
320	0,63 – 2,50	210-240	5÷7 x ø 6/6,5	8 ÷ 10 x ø 6/6,5	450	550
	0,63 – 2,50	320	4÷5 x ø 8	10 x ø 8		
	0,63 – 2,50	360	4÷5 x ø 9	10 x ø 9		
	0,63 – 2,50	400	3÷4 x ø 10	10 x ø 10		
450	0,63 – 2,50	210-240	6÷8 x ø 6/6,5	8 ÷ 10 x ø 6,5	650	850
	0,63 – 2,50	320	6÷7 x ø 8	10 x ø 8		
	0,63 – 2,50	360	5÷6 x ø 9	10 x ø 9		
	0,63 – 2,50	400	4÷5 x ø 10	10 x ø 10		
	0,63 – 2,50	450	4÷5 x ø 11	6 x ø 11		
	0,63 – 2,50	480	3÷4 x ø 11/12	6 x ø 11/12		
	0,63 – 2,50	520	3÷4 x ø 13	5 x ø 13		
	0,63 – 2,50	560	3÷4 x ø 14	5 x ø 14		
630	0,63 – 2,50	210-240	7÷9x ø 6/6,5	8 ÷ 10 x ø 6/6,5	850	1050
	0,63 – 2,50	320	6÷8 x ø 8	10 x ø 8		
	0,63 – 2,50	360	6÷8 x ø 9	10 x ø 9		
	0,63 – 2,50	400	5÷6 x ø 10	10 x ø 10		
	0,63 – 2,50	450	5÷6 x ø 11	6 x ø 11		
	0,63 – 2,50	480	4÷5 x ø 11/12	6 x ø 11/12		
800	0,63 – 2,50	210-240	8÷9x ø 6/6,5	8 ÷ 10 x ø 6/6,5	850	1200
	0,63 – 2,50	320	7÷8 x ø 8	10 x ø 8		
	0,63 – 2,50	360	7÷8 x ø 9	10 x ø 9		
	0,63 – 2,50	400	5÷6 x ø 10	10 x ø 10		
	0,63 – 2,50	450	5÷6 x ø 11	6 x ø 11		
	0,63 – 2,50	480	4÷5 x ø 11/12	6 x ø 11/12		
1000	0,63 – 2,50	240	9÷10x ø 6,5	10 x ø 6,5	900	1250
	0,63 – 2,50	320	8 x ø 8	10 x ø 8		
	0,63 – 2,50	360	8 x ø 9	10 x ø 9		
	0,63 – 2,50	400	6 x ø 10	10 x ø 10		

TIRO/ROPING 2/1 • Corsa/Travel 30 mt

Portata Duty loads [kg]	Velocità Speed [m/s]	Puleggia Sheave [mm]	* Combinazioni funi Ropes combination	N° Funi max, Installabile Max ropes nr.	Peso cabina Cabin Weight [kg]	
320	0,63 – 2,50	210-240	4÷5 ø 6/6,5	8 ÷ 10 x ø 6/6,5	500	600
	0,63 – 2,50	320	3÷4 x ø 8	10 x ø 8		
	0,63 – 2,50	360	3÷4 x ø 9	10 x ø 9		
	0,63 – 2,50	400	3÷4 x ø 10	10 x ø 10		
450	0,63 – 2,50	210-240	5÷6 x ø 6/6,5	8 ÷ 10 x ø 6/6,5	700	900
	0,63 – 2,50	320	4÷5 x ø 8	10 x ø 8		
	0,63 – 2,50	360	4÷5 x ø 9	10 x ø 9		
	0,63 – 2,50	400	3÷4 x ø 10	10 x ø 10		
	0,63 – 2,50	450	3÷4 x ø 11	6 x ø 11		
	0,63 – 2,50	480	3÷4 x ø 11/12	6 x ø 11/12		
	0,63 – 2,50	520	3÷4 x ø 13	5 x ø 13		
	0,63 – 2,50	560	3÷4 x ø 14	5 x ø 14		
0,63 – 2,50	600	3÷4 x ø 15	5 x ø 15			

* Altre combinazioni a richiesta
Additional combination on request

TIRO/ROPING 2/1 • Corsa/Travel 30 mt

Portata Duty loads [kg]	Velocità Speed [m/s]	Puleggia Sheave [mm]	* Combinazioni funi Ropes combination	N° Funì max, Installabile Max ropes nr.	Peso cabina Cabin Weight [kg]	
630	0,63 – 2,50	210-240	5÷7 x ø 6/6,5	10 x ø 6/6,5	900	1100
	0,63 – 2,50	320	5÷6 x ø 8	10 x ø 8		
	0,63 – 2,50	360	4÷5 x ø 9	10 x ø 9		
	0,63 – 2,50	400	3÷5 x ø 10	10 x ø 10		
	0,63 – 2,50	450	3÷4 x ø 11	6 x ø 11		
	0,63 – 2,50	480	3÷4 x ø 11/12	6 x ø 11/12		
	0,63 – 2,50	520	3÷4 x ø 13	5 x ø 13		
	0,63 – 2,50	560	3÷4 x ø 14	5 x ø 14		
0,63 – 2,50	600	3÷4 x ø 15	5 x ø 15			
800	0,63 – 2,50	210-240	6÷7x ø 6/6,5	10 x ø 6/6,5	900	1250
	0,63 – 2,50	320	5÷6 x ø 8	10 x ø 8		
	0,63 – 2,50	360	5÷6 x ø 9	10 x ø 9		
	0,63 – 2,50	400	4÷5 x ø 10	10 x ø 10		
	0,63 – 2,50	450	4÷5 x ø 11	6 x ø 11		
	0,63 – 2,50	480	4÷5 x ø 11/12	6 x ø 11/12		
	0,63 – 2,50	520	3÷4 x ø 13	5 x ø 13		
	0,63 – 2,50	560	3÷4 x ø 14	5 x ø 14		
0,63 – 2,50	600	3÷4 x ø 15	5 x ø 15			
1000	0,63 – 2,50	210-240	7÷8x ø 6/6,5	10 x ø 6/6,5	1100	1400
	0,63 – 2,50	320	7÷8 x ø 8	10 x ø 8		
	0,63 – 2,50	360	5÷6 x ø 9	10 x ø 9		
	0,63 – 2,50	400	4÷5 x ø 10	10 x ø 10		
	0,63 – 2,50	450	4÷5 x ø 11	6 x ø 11		
	0,63 – 2,50	480	4÷5 x ø 11/12	6 x ø 11/12		
	0,63 – 2,50	520	3÷4 x ø 13	5 x ø 13		
	0,63 – 2,50	560	3÷4 x ø 14	5 x ø 14		
0,63 – 2,50	600	3÷4 x ø 15	5 x ø 15			
1250	0,63 – 2,50	240	8÷9x ø 6,5	10 x ø 6,5	1250	1500
	0,63 – 2,50	320	7÷8 x ø 8	10 x ø 8		
	0,63 – 2,50	360	5÷7 x ø 9	10 x ø 9		
	0,63 – 2,50	400	4÷5 x ø 10	10 x ø 10		
	0,63 – 2,50	450	4÷5 x ø 11	6 x ø 11		
	0,63 – 2,50	480	4÷5 x ø 11/12	6 x ø 11/12		
	0,63 – 2,50	520	4÷5 x ø 13	5 x ø 13		
	0,63 – 2,50	560	3÷4 x ø 14	5 x ø 14		
0,63 – 2,50	600	3÷4 x ø 15	5 x ø 15			
1600	0,63 – 2,50	240	9÷10x ø 6,5	10 x ø 6,5	1500	1700
	0,63 – 2,50	320	8 x ø 8	10 x ø 8		
	0,63 – 2,50	360	7÷8 x ø 9	10 x ø 9		
	0,63 – 2,50	400	6÷7 x ø 10	10 x ø 10		
	0,63 – 2,50	450	5÷6 x ø 11	6 x ø 11		
	0,63 – 2,50	480	5÷6 x ø 11/12	6 x ø 11/12		
2000	0,63 – 2,50	240	10x ø 6,5	10 x ø 6,5	1800	2000
	0,63 – 2,50	320	8 x ø 8	10 x ø 8		
	0,63 – 2,50	360	8x ø 9	10 x ø 9		
	0,63 – 2,50	400	7÷8 x ø 10	10 x ø 10		

* Altre combinazioni a richiesta
Additional combination on request

G-500 Gearless



G-500 T1

Con o senza ventole di raffreddamento / With or without cooling fans

Carico statico / <i>Static load</i>	7600 kg							
Coppia / <i>Rated torque</i>	1600 Nm							
Peso / <i>Weight</i>	510 kg without sheave							
Portata / <i>Duty load</i> [kg]	1000	1250	1250	1600	2000	2500	2500	4000
Tiro / <i>Suspension</i>	1/1	1/1	2/1	2/1	2/1	2/1	4/1	4/1
Gamma velocità cabina <i>Range of cabin speed</i> [m/s]	0,63 ÷ 2,50	0,63 ÷ 2,50	0,63 ÷ 2,50	0,63 ÷ 2,50	0,63 ÷ 2,50	0,63 ÷ 2,0	0,63 ÷ 1,60	0,63 ÷ 1,00
Gamma Ø pulegge <i>Range sheave Ø</i> [mm]	360 - 400 450	360	360 - 400 450 - 480 520 - 560 600 - 650	360 - 400 450 - 480 520 - 560	360 - 400 450	360	360 - 400 450 - 480 520 - 560 600 - 650	360 - 400 450
Max Combinazione funi/ <i>Max ropes combination</i>	n°12 Ø 9 mm n°10 Ø 11 mm	n°12 Ø 9 mm	n°12 Ø 9 mm n°8 Ø 16 mm	n°12 Ø 9 mm n°8 Ø 14 mm	n°12 Ø 9 mm n°10 Ø 11 mm	n°12 Ø 9 mm	n°12 Ø 9 mm n°8 Ø 16 mm	n°12 Ø 9 mm n°10 Ø 11 mm

20 poles

A richiesta disponibili:
Leva apertura
manuale freno.

Available on request:
Lever for
hand release.



G-500 T2

Con ventole di raffreddamento / With cooling fans

Carico statico / <i>Static load</i>	7600 kg						
Coppia / <i>Rated torque</i>	2200 Nm						
Peso / <i>Weight</i>	630 kg without sheave						
Portata / <i>Duty load</i> [kg]	1000-1250	1600	2000	2500	4000	5000	
Tiro / <i>Suspension</i>	1/1	1/1	2/1	2/1	4/1	4/1	
Gamma velocità cabina <i>Range of cabin speed</i> [m/s]	0,63 ÷ 2,50	0,63 ÷ 2,50	0,63 ÷ 2,50	0,63 ÷ 2,50	0,63 - 1,60	0,63 - 1,00	
Gamma Ø pulegge <i>Range sheave Ø</i> [mm]	360 - 400 - 480 520 - 560 - 600 650	360 - 400	360 - 400 - 450 480 - 520 560 - 600 - 650	400 - 450 480 - 520	360 - 400 - 450 480 - 520 560 - 600	360 - 400 - 450 480 - 520	
Max Combinazione funi/ <i>Max ropes combination</i>	n°12 Ø 9 mm n°8 Ø 16 mm	n°12 Ø 9 mm n°12 Ø 10 mm	n°12 Ø 9 mm n°8 Ø 16 mm	n°12 Ø 10 mm n°8 Ø 13 mm	n°12 Ø 9 mm n°8 Ø 15 mm	n°12 Ø 9 mm n°8 Ø 13 mm	

20 poles



G-500 Con ventilatori / With cooling fans (T1 TOTAL FANS 2 T2 TOTAL FANS 4)

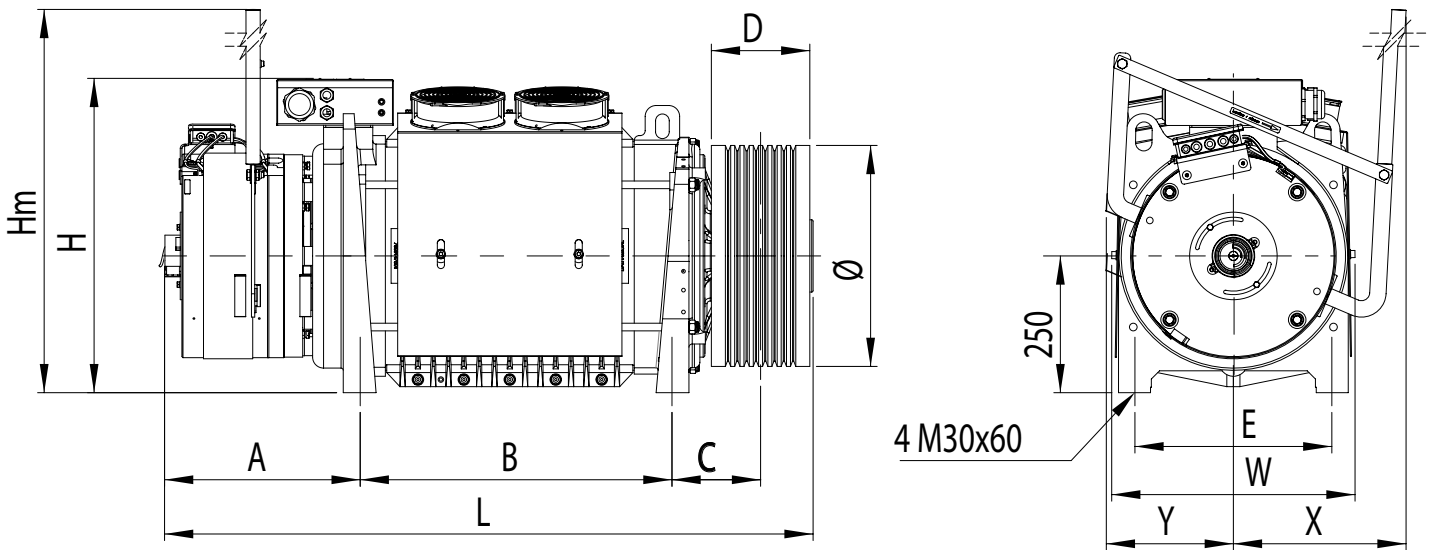

TIPO/TYPE	A	L	B	C	E	W	X	Y	Hm	H	D	Ø
G-500 T1	358	1027	410	162	360	445	700**	230	918	575	180*	360÷650
G-500 T2	358	1187	570	162	360	445	700**	230	918	575	180*	360÷650

Brake manual release as optional

* Ø > 450 mm: pulegge con flangia
Ø > 450 mm: flanged traction sheave

** Dimensione massima apertura con leva
Max opening dimension with lever

G-500 Senza ventilatori / Without cooling fans

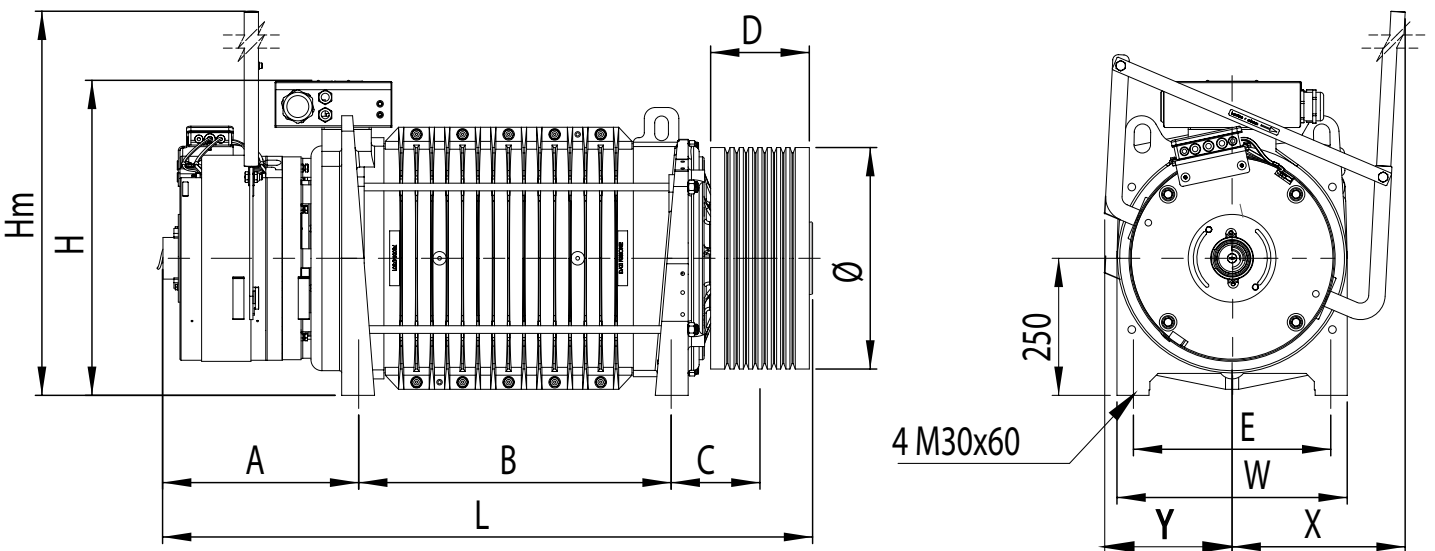

TIPO/TYPE	A	L	B	C	E	W	X	Y	Hm	H	D	Ø
G-500 T1	358	1027	410	162	360	420	700**	230	918	575	180*	360÷650
G-500 T2	358	1187	570	162	360	420	700**	230	918	575	180*	360÷650

Brake manual release as optional

* Ø > 450 mm: pulegge con flangia
Ø > 450 mm: flanged traction sheave

** Dimensione massima apertura con leva
Max opening dimension with lever



G-500 T1 IP66 Senza ventilatori / Without cooling fans *



* configurazione solo senza ventilatore né leve del freno / only configuration without neither fan nor brake levers.

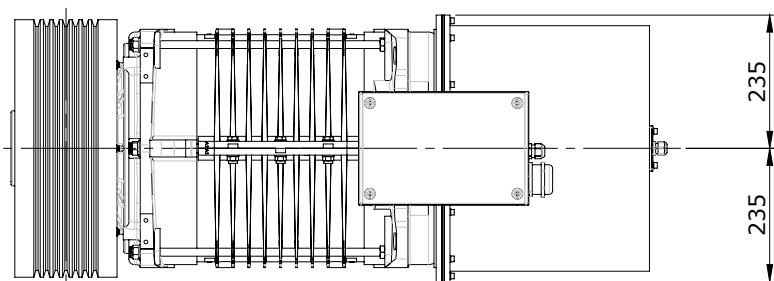
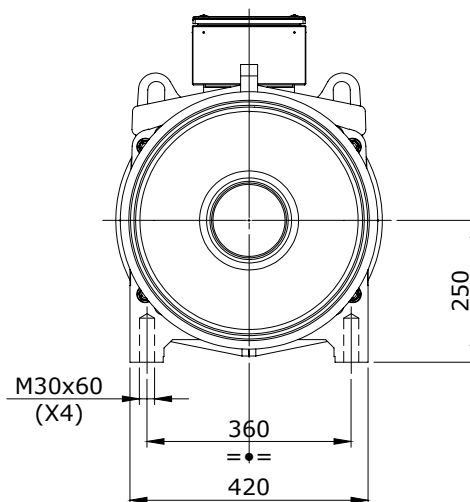
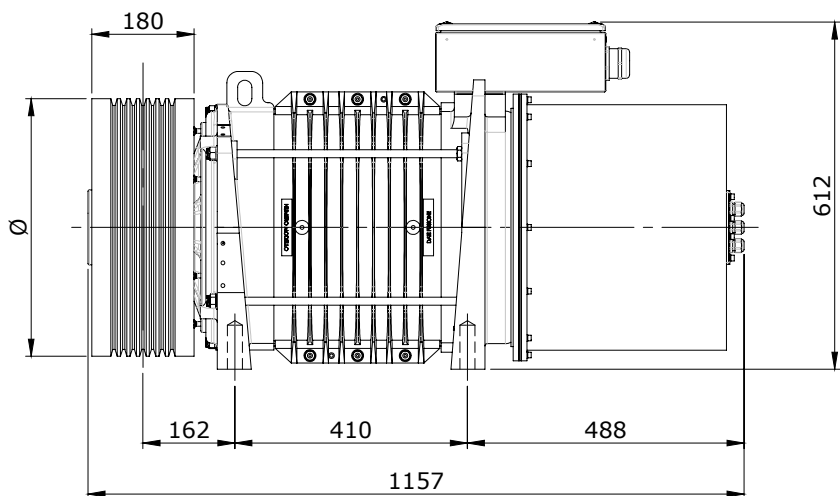

G-500 T2 IP66 Senza ventilatori / Without cooling fans *



* configurazione solo senza ventilatore né leve del freno / only configuration without neither fan nor brake levers.

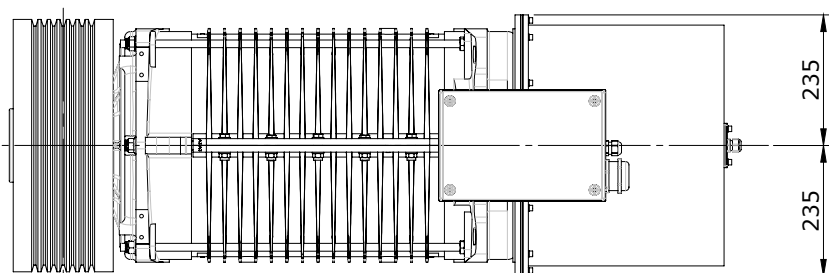
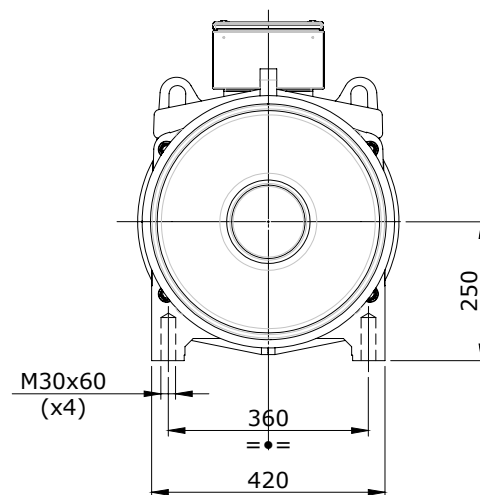
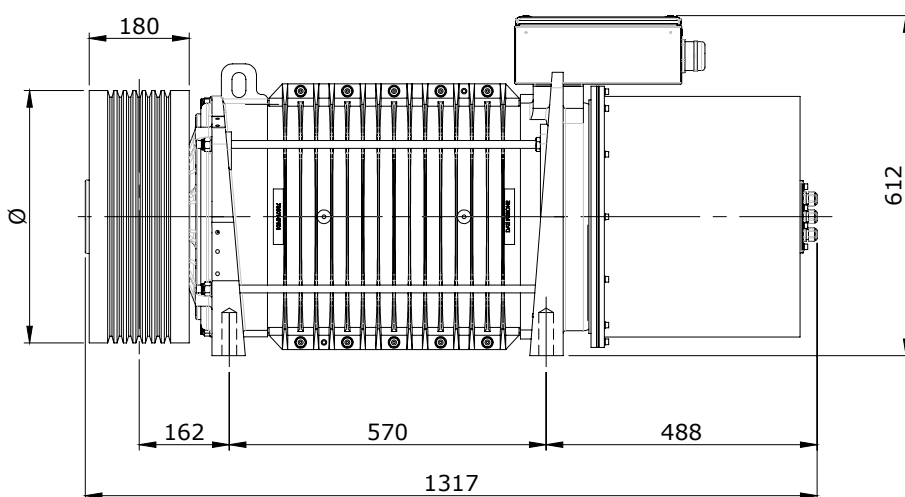

TIPO/TYPE	L	Ø
G-500 T1	1157	360 - 400 - 450 - 480 - 520 - 560 - 600 - 650
G-500 T2	1317	



G-500 T1 Con ventilatore VT330 / With cooling fan *

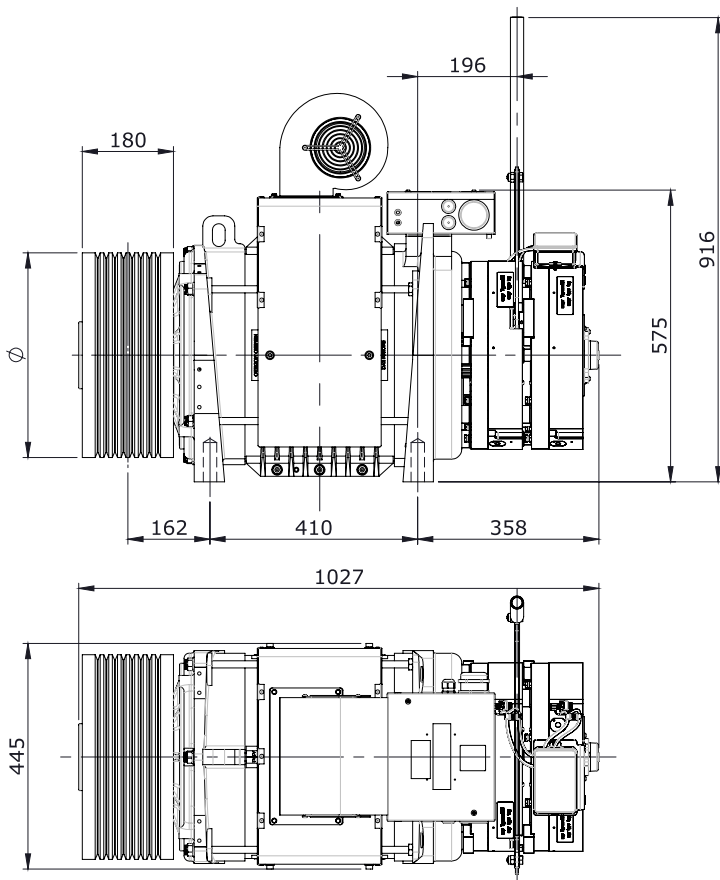

A richiesta disponibili:
Leva apertura
manuale freno.

Available on request:
Lever for
hand release.

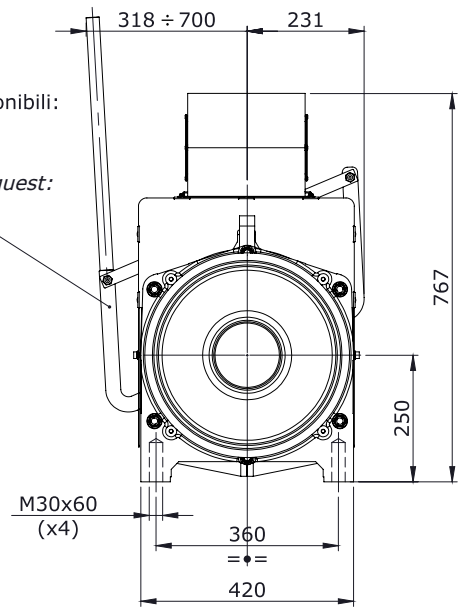

* Per un maggiore ciclo di lavoro rispetto allo standard.
Chiedere all'ufficio commerciale per maggiori informazioni
*For increased duty-cycle than the standard.
Ask the Sales dpt. for more information.*

G-500 T2 Con ventilatore VT330 / With cooling fan *

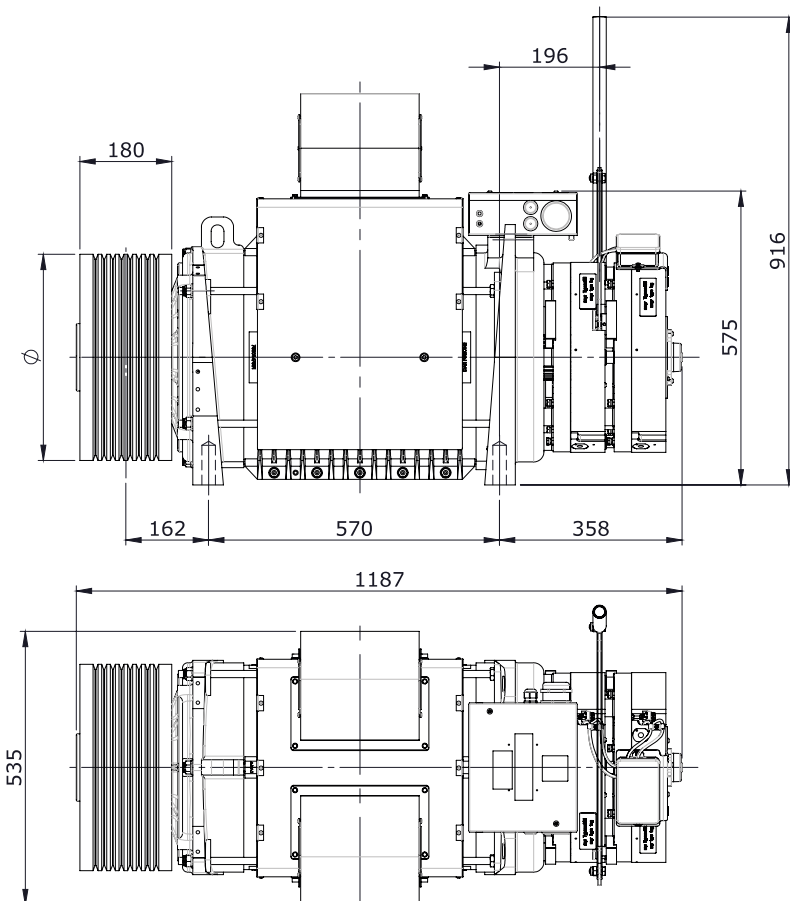

A richiesta disponibili:
Leva apertura
manuale freno.

Available on request:
Lever for
hand release.

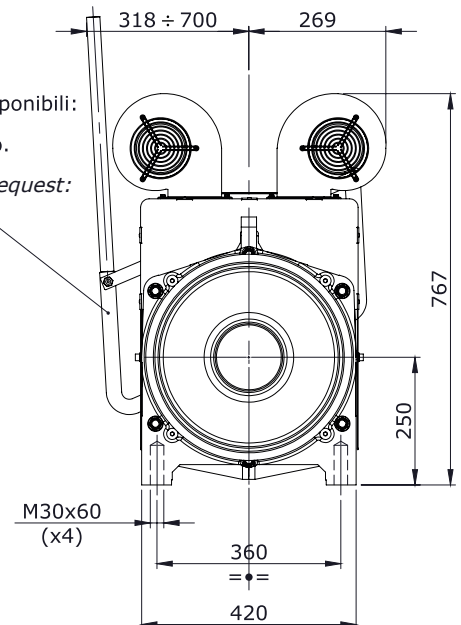

TIPO/TYPE	Ø
G-500 T1 VT330	360 - 400 - 450 - 480 - 520 - 560 - 600 - 650
G-500 T2 VT330	

G-500 T1 Gearless



Tiro <i>Roping Factor</i>	Peso funi max <i>Max Ropes Weight [kg]</i>	Portata <i>Duty Load [kg]</i>	Velocità cabina <i>Cabin Speed [m/s]</i>	Ø Puleggia <i>Ø Sheave Diameter [mm]</i>	Poli <i>Poles</i>	Velocità <i>Speed [rpm]</i>	Frequenza <i>Frequency [Hz]</i>	Efficienza vano <i>Shaft Efficiency</i>	Coppia <i>Torque [Nm]</i>	Potenza in uscita <i>Power Output [kW]</i>
	(1)			(2)			(4)	(3)		
1	80	800	0,63	360	20	33,4	5,57	0,85	997	3,5
1	80	800	0,63	400	20	30,1	5,01	0,85	1108	3,5
1	80	800	0,63	450	20	26,7	4,46	0,85	1246	3,5
1	80	800	0,63	480	20	25,1	4,18	0,85	1330	3,5
1	80	800	0,63	520	20	23,1	3,86	0,85	1440	3,5
1	80	800	0,63	560	20	21,5	3,58	0,85	1551	3,5
1	80	800	1	360	20	53,1	8,84	0,85	997	5,5
1	80	800	1	400	20	47,7	7,96	0,85	1108	5,5
1	80	800	1	450	20	42,4	7,07	0,85	1246	5,5
1	80	800	1	480	20	39,8	6,63	0,85	1330	5,5
1	80	800	1	520	20	36,7	6,12	0,85	1440	5,5
1	80	800	1	560	20	34,1	5,68	0,85	1551	5,5
1	80	800	1,6	360	20	84,9	14,15	0,85	997	8,9
1	80	800	1,6	400	20	76,4	12,73	0,85	1108	8,9
1	80	800	1,6	450	20	67,9	11,32	0,85	1246	8,9
1	80	800	1,6	480	20	63,7	10,61	0,85	1330	8,9
1	80	800	1,6	520	20	58,8	9,79	0,85	1440	8,9
1	80	800	1,6	560	20	54,6	9,09	0,85	1551	8,9
1	80	800	2,5	360	20	132,6	22,10	0,85	997	13,8
1	80	800	2,5	400	20	119,4	19,89	0,85	1108	13,8
1	80	800	2,5	450	20	106,1	17,68	0,85	1246	13,8
1	80	800	2,5	480	20	99,5	16,58	0,85	1330	13,8
1	80	800	2,5	520	20	91,8	15,30	0,85	1440	13,8
1	80	800	2,5	560	20	85,3	14,21	0,85	1551	13,8
1	80	1000	0,63	360	20	33,4	5,57	0,85	1205	4,2
1	80	1000	0,63	400	20	30,1	5,01	0,85	1339	4,2
1	80	1000	0,63	450	20	26,7	4,46	0,85	1506	4,2
1	80	1000	1	360	20	53,1	8,84	0,85	1205	6,7
1	80	1000	1	400	20	47,7	7,96	0,85	1339	6,7
1	80	1000	1	450	20	42,4	7,07	0,85	1506	6,7
1	80	1000	1,6	360	20	84,9	14,15	0,85	1205	10,7
1	80	1000	1,6	400	20	76,4	12,73	0,85	1339	10,7
1	80	1000	1,6	450	20	67,9	11,32	0,85	1506	10,7
1	80	1000	2,5	360	20	132,6	22,10	0,85	1205	16,7
1	80	1000	2,5	400	20	119,4	19,89	0,85	1339	16,7
1	80	1000	2,5	450	20	106,1	17,68	0,85	1506	16,7
1	80	1250	0,63	360	20	33,4	5,57	0,85	1465	5,1
1	80	1250	1	360	20	53,1	8,84	0,85	1465	8,1
1	80	1250	1,6	360	20	84,9	14,15	0,85	1465	13,0
1	80	1250	2	360	20	106,1	17,68	0,85	1465	16,3
1	80	1250	2,5	360	20	132,6	22,10	0,85	1465	20,3
2	80	1250	0,63	560	20	43,0	7,16	0,85	1268	5,7
2	80	1250	0,63	600	20	40,1	6,68	0,85	1359	5,7
2	80	1250	0,63	650	20	37,0	6,17	0,85	1472	5,7
2	80	1250	1	560	20	68,2	11,37	0,85	1268	9,1
2	80	1250	1	600	20	63,7	10,61	0,85	1359	9,1
2	80	1250	1	650	20	58,8	9,79	0,85	1472	9,1



Tiro	Peso funi max	Portata	Velocità cabina	Ø Puleggia	Poli	Velocità	Frequenza	Efficienza vano	Coppia	Potenza in uscita
Roping Factor	Max Ropes Weight [kg]	Duty Load [kg]	Cabin Speed [m/s]	Ø Sheave Diameter [mm]	Poles	Speed [rpm]	Frequency [Hz]	Shaft Efficiency	Torque [Nm]	Power Output [kW]
	(1)			(2)			(4)	(3)		
2	80	1250	1,6	560	20	109,1	18,19	0,85	1268	14,5
2	80	1250	1,6	600	20	101,9	16,98	0,85	1359	14,5
2	80	1250	1,6	650	20	94,0	15,67	0,85	1472	14,5
2	80	1250	2	560	20	136,4	22,74	0,85	1268	18,1
2	80	1250	2	600	20	127,3	21,22	0,85	1359	18,1
2	80	1250	2	650	20	117,5	19,59	0,85	1472	18,1
2	80	1250	2,5	560	20	170,5	28,42	0,85	1268	22,6
2	80	1250	2,5	600	20	159,2	26,53	0,85	1359	22,6
2	80	1250	2,5	650	20	146,9	24,49	0,85	1472	22,6
2	80	1600	0,63	480	20	50,1	8,36	0,85	1330	7,0
2	80	1600	0,63	520	20	46,3	7,71	0,85	1440	7,0
2	80	1600	0,63	560	20	43,0	7,16	0,85	1551	7,0
2	80	1600	1	480	20	79,6	13,26	0,85	1330	11,1
2	80	1600	1	520	20	73,5	12,24	0,85	1440	11,1
2	80	1600	1	560	20	68,2	11,37	0,85	1551	11,1
2	80	1600	1,6	480	20	127,3	21,22	0,85	1330	17,7
2	80	1600	1,6	520	20	117,5	19,59	0,85	1440	17,7
2	80	1600	1,6	560	20	109,1	18,19	0,85	1551	17,7
2	80	1600	2	480	20	159,2	26,53	0,85	1330	22,2
2	80	1600	2	520	20	146,9	24,49	0,85	1440	22,2
2	80	1600	2	560	20	136,4	22,74	0,85	1551	22,2
2	80	1600	2,5	480	20	198,9	33,16	0,85	1330	27,7
2	80	1600	2,5	520	20	183,6	30,61	0,85	1440	27,7
2	80	1600	2,5	560	20	170,5	28,42	0,85	1551	27,7
2	80	2000	0,63	360	20	66,8	11,14	0,85	1205	8,4
2	80	2000	0,63	400	20	60,2	10,03	0,85	1339	8,4
2	80	2000	0,63	450	20	53,5	8,91	0,85	1506	8,4
2	80	2000	1	360	20	106,1	17,68	0,85	1205	13,4
2	80	2000	1	400	20	95,5	15,92	0,85	1339	13,4
2	80	2000	1	450	20	84,9	14,15	0,85	1506	13,4
2	80	2000	1,6	360	20	169,8	28,29	0,85	1205	21,4
2	80	2000	1,6	400	20	152,8	25,46	0,85	1339	21,4
2	80	2000	1,6	450	20	135,8	22,64	0,85	1506	21,4
2	80	2000	2	360	20	212,2	35,37	0,85	1205	26,8
2	80	2000	2	400	20	191,0	31,83	0,85	1339	26,8
2	80	2000	2	450	20	169,8	28,29	0,85	1506	26,8
2	80	2000	2,5	400	20	238,7	39,79	0,85	1339	33,5
2	80	2000	2,5	450	20	212,2	35,37	0,85	1506	33,5
2	80	2500	0,63	360	20	66,8	11,14	0,85	1465	10,3
2	80	2500	1	360	20	106,1	17,68	0,85	1465	16,3
2	80	2500	1,6	360	20	169,8	28,29	0,85	1465	26,0
2	80	2500	2	360	20	212,2	35,37	0,85	1465	32,5
4	80	2500	0,63	360	20	133,7	22,28	0,82	845	11,8
4	80	2500	0,63	400	20	120,3	20,05	0,82	939	11,8
4	80	2500	0,63	450	20	107,0	17,83	0,82	1057	11,8
4	80	2500	0,63	480	20	100,3	16,71	0,82	1127	11,8



Tiro <i>Roping Factor</i>	Peso funi max <i>Max Ropes Weight [kg]</i>	Portata <i>Duty Load [kg]</i>	Velocità cabina <i>Cabin Speed [m/s]</i>	Ø Puleggia <i>Ø Sheave Diameter [mm]</i>	Poli <i>Poles</i>	Velocità <i>Speed [rpm]</i>	Frequenza <i>Frequency [Hz]</i>	Efficienza vano <i>Shaft Efficiency</i>	Coppia <i>Torque [Nm]</i>	Potenza in uscita <i>Power Output [kW]</i>
	(1)			(2)			(4)	(3)		
4	80	2500	0,63	520	20	92,6	15,43	0,82	1221	11,8
4	80	2500	0,63	560	20	85,9	14,32	0,82	1315	11,8
4	80	2500	0,63	600	20	80,2	13,37	0,82	1409	11,8
4	80	2500	0,63	650	20	74,0	12,34	0,82	1526	11,8
4	80	2500	1	360	20	212,2	35,37	0,82	845	18,8
4	80	2500	1	400	20	191,0	31,83	0,82	939	18,8
4	80	2500	1	450	20	169,8	28,29	0,82	1057	18,8
4	80	2500	1	480	20	159,2	26,53	0,82	1127	18,8
4	80	2500	1	520	20	146,9	24,49	0,82	1221	18,8
4	80	2500	1	560	20	136,4	22,74	0,82	1315	18,8
4	80	2500	1	600	20	127,3	21,22	0,82	1409	18,8
4	80	2500	1	650	20	117,5	19,59	0,82	1526	18,8
4	80	2500	1,6	480	20	254,6	42,44	0,82	1127	30,1
4	80	2500	1,6	520	20	235,1	39,18	0,82	1221	30,1
4	80	2500	1,6	560	20	218,3	36,38	0,82	1315	30,1
4	80	2500	1,6	600	20	203,7	33,95	0,82	1409	30,1
4	80	2500	1,6	650	20	188,0	31,34	0,82	1526	30,1
4	80	4000	0,63	360	20	133,7	22,28	0,82	1249	17,5
4	80	4000	0,63	400	20	120,3	20,05	0,82	1388	17,5
4	80	4000	0,63	450	20	107,0	17,83	0,82	1561	17,5
4	80	4000	1	360	20	212,2	35,37	0,82	1249	27,8
4	80	4000	1	400	20	191,0	31,83	0,82	1388	27,8
4	80	4000	1	450	20	169,8	28,29	0,82	1561	27,8

C_Max [Nm] = 1600

G-500 T1 - NOTE

Brake Type: Mayr - ROBA-STOP-SILENZIO-1300 207 Vdc. Hand release lever available on request.

Static Load: 7600 kg.

Encoder Type: Absolute encoder with EnDat Interface or Incremental sin/cos, both with 2048 ppr;

Note 1: For higher ropes weight, please consult sales/technical services of Alberto Sassi SpA.

Note 2: Details on ropes/grooves provided upon lift data.

Note 3: Shaft efficiency includes divertor pulleys efficiency by considering: 3 divertors for roping 2:1 and 7 divertors for roping 4:1. Values are supposed.

Note 4: For frequencies lower than 5 Hz, please consult your inverter supplier.

Note 5: Max 180 sts/h - 30% ED without fans.
Max 240 sts/h - 50% ED with fans activated by thermocontacts inside motor.

Note 6: MAYR's certified brake against Overspeed in upward direction and as UCM (EN 81-20:2014, EN 81-50:2014) with reference to Lift Directive 2014/33/EU.

Note 7: Traction sheave width: 180 mm.

Note 8: Weight 510 kg (without sheave).

The Alberto Sassi SpA reserves the rights to change data and features without previous notice.



Tiro	Peso funi max	Portata	Velocità cabina	Ø Puleggia	Poli	Velocità	Frequenza	Efficienza vano	Coppia	Potenza in uscita
<i>Roping Factor</i>	<i>Max Ropes Weight [kg]</i>	<i>Duty Load [kg]</i>	<i>Cabin Speed [m/s]</i>	<i>Ø Sheave Diameter [mm]</i>	<i>Poles</i>	<i>Speed [rpm]</i>	<i>Frequency [Hz]</i>	<i>Shaft Efficiency</i>	<i>Torque [Nm]</i>	<i>Power Output [kW]</i>
	(1)			(2)			(4)	(3)		
1	80	800	0,63	560	20	21,5	3,58	0,85	1551	3,5
1	80	800	0,63	600	20	20,1	3,34	0,85	1662	3,5
1	80	800	1	560	20	34,1	5,68	0,85	1551	5,5
1	80	800	1	600	20	31,8	5,31	0,85	1662	5,5
1	80	800	1	650	20	29,4	4,90	0,85	1800	5,5
1	80	800	1,6	560	20	54,6	9,09	0,85	1551	8,9
1	80	800	1,6	600	20	50,9	8,49	0,85	1662	8,9
1	80	800	1,6	650	20	47,0	7,84	0,85	1800	8,9
1	80	800	2	560	20	68,2	11,37	0,85	1551	11,1
1	80	800	2	600	20	63,7	10,61	0,85	1662	11,1
1	80	800	2	650	20	58,8	9,79	0,85	1800	11,1
1	80	800	2,5	560	20	85,3	14,21	0,85	1551	13,8
1	80	800	2,5	600	20	79,6	13,26	0,85	1662	13,8
1	80	800	2,5	650	20	73,5	12,24	0,85	1800	13,8
1	80	1000	0,63	450	20	26,7	4,46	0,85	1506	4,2
1	80	1000	0,63	480	20	25,1	4,18	0,85	1607	4,2
1	80	1000	0,63	520	20	23,1	3,86	0,85	1740	4,2
1	80	1000	0,63	560	20	21,5	3,58	0,85	1874	4,2
1	80	1000	0,63	600	20	20,1	3,34	0,85	2008	4,2
1	80	1000	1	450	20	42,4	7,07	0,85	1506	6,7
1	80	1000	1	480	20	39,8	6,63	0,85	1607	6,7
1	80	1000	1	520	20	36,7	6,12	0,85	1740	6,7
1	80	1000	1	560	20	34,1	5,68	0,85	1874	6,7
1	80	1000	1	600	20	31,8	5,31	0,85	2008	6,7
1	80	1000	1	650	20	29,4	4,90	0,85	2176	6,7
1	80	1000	1,6	450	20	67,9	11,32	0,85	1506	10,7
1	80	1000	1,6	480	20	63,7	10,61	0,85	1607	10,7
1	80	1000	1,6	520	20	58,8	9,79	0,85	1740	10,7
1	80	1000	1,6	560	20	54,6	9,09	0,85	1874	10,7
1	80	1000	1,6	600	20	50,9	8,49	0,85	2008	10,7
1	80	1000	1,6	650	20	47,0	7,84	0,85	2176	10,7
1	80	1000	2	450	20	84,9	14,15	0,85	1506	13,4
1	80	1000	2	480	20	79,6	13,26	0,85	1607	13,4
1	80	1000	2	520	20	73,5	12,24	0,85	1740	13,4
1	80	1000	2	560	20	68,2	11,37	0,85	1874	13,4
1	80	1000	2	600	20	63,7	10,61	0,85	2008	13,4
1	80	1000	2	650	20	58,8	9,79	0,85	2176	13,4
1	80	1000	2,5	450	20	106,1	17,68	0,85	1506	16,7
1	80	1000	2,5	480	20	99,5	16,58	0,85	1607	16,7
1	80	1000	2,5	520	20	91,8	15,30	0,85	1740	16,7
1	80	1000	2,5	560	20	85,3	14,21	0,85	1874	16,7
1	80	1000	2,5	600	20	79,6	13,26	0,85	2008	16,7
1	80	1000	2,5	650	20	73,5	12,24	0,85	2176	16,7
1	80	1250	0,63	360	20	33,4	5,57	0,85	1465	5,1
1	80	1250	0,63	400	20	30,1	5,01	0,85	1627	5,1
1	80	1250	0,63	450	20	26,7	4,46	0,85	1831	5,1
1	80	1250	0,63	480	20	25,1	4,18	0,85	1953	5,1
1	80	1250	0,63	520	20	23,1	3,86	0,85	2115	5,1
1	80	1250	1	360	20	53,1	8,84	0,85	1465	8,1
1	80	1250	1	400	20	47,7	7,96	0,85	1627	8,1
1	80	1250	1	450	20	42,4	7,07	0,85	1831	8,1
1	80	1250	1	480	20	39,8	6,63	0,85	1953	8,1
1	80	1250	1	520	20	36,7	6,12	0,85	2115	8,1
1	80	1250	1,6	360	20	84,9	14,15	0,85	1465	13,0
1	80	1250	1,6	400	20	76,4	12,73	0,85	1627	13,0
1	80	1250	1,6	450	20	67,9	11,32	0,85	1831	13,0
1	80	1250	1,6	480	20	63,7	10,61	0,85	1953	13,0
1	80	1250	1,6	520	20	58,8	9,79	0,85	2115	13,0

G-500 T2 Gearless



Tiro	Peso funi max	Portata	Velocità cabina	Ø Puleggia	Poli	Velocità	Frequenza	Efficienza vano	Coppia	Potenza in uscita
Roping Factor	Max Ropes Weight [kg]	Duty Load [kg]	Cabin Speed [m/s]	Ø Sheave Diameter [mm]	Poles	Speed [rpm]	Frequency [Hz]	Shaft Efficiency	Torque [Nm]	Power Output [kW]
	(1)			(2)			(4)	(3)		
1	80	1250	2	360	20	106,1	17,68	0,85	1465	16,3
1	80	1250	2	400	20	95,5	15,92	0,85	1627	16,3
1	80	1250	2	450	20	84,9	14,15	0,85	1831	16,3
1	80	1250	2	480	20	79,6	13,26	0,85	1953	16,3
1	80	1250	2	520	20	73,5	12,24	0,85	2115	16,3
1	80	1250	2,5	360	20	132,6	22,10	0,85	1465	20,3
1	80	1250	2,5	400	20	119,4	19,89	0,85	1627	20,3
1	80	1250	2,5	450	20	106,1	17,68	0,85	1831	20,3
1	80	1250	2,5	480	20	99,5	16,58	0,85	1953	20,3
1	80	1250	2,5	520	20	91,8	15,30	0,85	2115	20,3
1	80	1600	0,63	360	20	33,4	5,57	0,85	1828	6,4
1	80	1600	0,63	400	20	30,1	5,01	0,85	2031	6,4
1	80	1600	1	360	20	53,1	8,84	0,85	1828	10,2
1	80	1600	1	400	20	47,7	7,96	0,85	2031	10,2
1	80	1600	1,6	360	20	84,9	14,15	0,85	1828	16,2
1	80	1600	1,6	400	20	76,4	12,73	0,85	2031	16,2
1	80	1600	2	360	20	106,1	17,68	0,85	1828	20,3
1	80	1600	2	400	20	95,5	15,92	0,85	2031	20,3
1	80	1600	2,5	360	20	132,6	22,10	0,85	1828	25,4
1	80	1600	2,5	400	20	119,4	19,89	0,85	2031	25,4
2	80	2000	0,63	450	20	53,5	8,91	0,85	1506	8,4
2	80	2000	0,63	480	20	50,1	8,36	0,85	1607	8,4
2	80	2000	0,63	520	20	46,3	7,71	0,85	1740	8,4
2	80	2000	0,63	560	20	43,0	7,16	0,85	1874	8,4
2	80	2000	0,63	600	20	40,1	6,68	0,85	2008	8,4
2	80	2000	0,63	650	20	37,0	6,17	0,85	2176	8,4
2	80	2000	1	450	20	84,9	14,15	0,85	1506	13,4
2	80	2000	1	480	20	79,6	13,26	0,85	1607	13,4
2	80	2000	1	520	20	73,5	12,24	0,85	1740	13,4
2	80	2000	1	560	20	68,2	11,37	0,85	1874	13,4
2	80	2000	1	600	20	63,7	10,61	0,85	2008	13,4
2	80	2000	1	650	20	58,8	9,79	0,85	2176	13,4
2	80	2000	1,6	450	20	135,8	22,64	0,85	1506	21,4
2	80	2000	1,6	480	20	127,3	21,22	0,85	1607	21,4
2	80	2000	1,6	520	20	117,5	19,59	0,85	1740	21,4
2	80	2000	1,6	560	20	109,1	18,19	0,85	1874	21,4
2	80	2000	1,6	600	20	101,9	16,98	0,85	2008	21,4
2	80	2000	1,6	650	20	94,0	15,67	0,85	2176	21,4
2	80	2000	2	450	20	169,8	28,29	0,85	1506	26,8
2	80	2000	2	480	20	159,2	26,53	0,85	1607	26,8
2	80	2000	2	520	20	146,9	24,49	0,85	1740	26,8
2	80	2000	2	560	20	136,4	22,74	0,85	1874	26,8
2	80	2000	2	600	20	127,3	21,22	0,85	2008	26,8
2	80	2000	2	650	20	117,5	19,59	0,85	2176	26,8
2	80	2000	2,5	450	20	212,2	35,37	0,85	1506	33,5
2	80	2000	2,5	480	20	198,9	33,16	0,85	1607	33,5
2	80	2000	2,5	520	20	183,6	30,61	0,85	1740	33,5
2	80	2000	2,5	560	20	170,5	28,42	0,85	1874	33,5
2	80	2000	2,5	600	20	159,2	26,53	0,85	2008	33,5
2	80	2000	2,5	650	20	146,9	24,49	0,85	2176	33,5
2	80	2500	0,63	360	20	66,8	11,14	0,85	1465	10,3
2	80	2500	0,63	400	20	60,2	10,03	0,85	1627	10,3
2	80	2500	0,63	450	20	53,5	8,91	0,85	1831	10,3
2	80	2500	0,63	480	20	50,1	8,36	0,85	1953	10,3
2	80	2500	0,63	520	20	46,3	7,71	0,85	2115	10,3
2	80	2500	1	360	20	106,1	17,68	0,85	1465	16,3
2	80	2500	1	400	20	95,5	15,92	0,85	1627	16,3
2	80	2500	1	450	20	84,9	14,15	0,85	1831	16,3



Tiro <i>Roping Factor</i>	Peso funi max <i>Max Ropes Weight [kg]</i>	Portata <i>Duty Load [kg]</i>	Velocità cabina <i>Cabin Speed [m/s]</i>	Ø Puleggia <i>Ø Sheave Diameter [mm]</i>	Poli <i>Poles</i>	Velocità <i>Speed [rpm]</i>	Frequenza <i>Frequency [Hz]</i>	Efficienza vano <i>Shaft Efficiency</i>	Coppia <i>Torque [Nm]</i>	Potenza in uscita <i>Power Output [kW]</i>
	(1)			(2)			(4)	(3)		
2	80	2500	1	480	20	79,6	13,26	0,85	1953	16,3
2	80	2500	1	520	20	73,5	12,24	0,85	2115	16,3
2	80	2500	1,6	360	20	169,8	28,29	0,85	1465	26,0
2	80	2500	1,6	400	20	152,8	25,46	0,85	1627	26,0
2	80	2500	1,6	450	20	135,8	22,64	0,85	1831	26,0
2	80	2500	1,6	480	20	127,3	21,22	0,85	1953	26,0
2	80	2500	1,6	520	20	117,5	19,59	0,85	2115	26,0
2	80	2500	2	360	20	212,2	35,37	0,85	1465	32,5
2	80	2500	2	400	20	191,0	31,83	0,85	1627	32,5
2	80	2500	2	450	20	169,8	28,29	0,85	1831	32,5
2	80	2500	2	480	20	159,2	26,53	0,85	1953	32,5
2	80	2500	2	520	20	146,9	24,49	0,85	2115	32,5
2	80	2500	2,5	400	20	238,7	39,79	0,85	1627	40,7
2	80	2500	2,5	450	20	212,2	35,37	0,85	1831	40,7
2	80	2500	2,5	480	20	198,9	33,16	0,85	1953	40,7
2	80	2500	2,5	520	20	183,6	30,61	0,85	2115	40,7
4	80	4000	0,63	450	20	107,0	17,83	0,82	1561	17,5
4	80	4000	0,63	480	20	100,3	16,71	0,82	1665	17,5
4	80	4000	0,63	520	20	92,6	15,43	0,82	1804	17,5
4	80	4000	0,63	560	20	85,9	14,32	0,82	1943	17,5
4	80	4000	0,63	600	20	80,2	13,37	0,82	2082	17,5
4	80	4000	1	450	20	169,8	28,29	0,82	1561	27,8
4	80	4000	1	480	20	159,2	26,53	0,82	1665	27,8
4	80	4000	1	520	20	146,9	24,49	0,82	1804	27,8
4	80	4000	1	560	20	136,4	22,74	0,82	1943	27,8
4	80	4000	1	600	20	127,3	21,22	0,82	2082	27,8
4	80	4000	1,6	480	20	254,6	42,44	0,82	1665	44,4
4	80	4000	1,6	520	20	235,1	39,18	0,82	1804	44,4
4	80	4000	1,6	560	20	218,3	36,38	0,82	1943	44,4
4	80	4000	1,6	600	20	203,7	33,95	0,82	2082	44,4
4	80	5000	0,63	360	20	133,7	22,28	0,82	1518	21,3
4	80	5000	0,63	400	20	120,3	20,05	0,82	1687	21,3
4	80	5000	0,63	450	20	107,0	17,83	0,82	1898	21,3
4	80	5000	0,63	480	20	100,3	16,71	0,82	2024	21,3
4	80	5000	0,63	520	20	92,6	15,43	0,82	2193	21,3
4	80	5000	1	360	20	212,2	35,37	0,82	1518	33,7
4	80	5000	1	400	20	191,0	31,83	0,82	1687	33,7
4	80	5000	1	450	20	169,8	28,29	0,82	1898	33,7
4	80	5000	1	480	20	159,2	26,53	0,82	2024	33,7
4	80	5000	1	520	20	146,9	24,49	0,82	2193	33,7
4	80	5000	1,6	480	20	254,6	42,44	0,82	2024	54,0
4	80	5000	1,6	520	20	235,1	39,18	0,82	2193	54,0

C_Max [Nm] = 2200**G-500 T2 - NOTE****Brake Type:** Mayr - ROBA-STOP-SILENZIO-1300 207 Vdc. Hand release lever available on request.**Static Load:** 7600 kg.**Encoder Type:** Absolute Heidenhain with EnDat Interface - Other type on request.**Note 1:** For higher ropes weight, please consult sales/technical services of Alberto Sassi SpA.**Note 2:** Details on ropes/grooves provided upon lift data.**Note 3:** Shaft efficiency includes divertor pulleys efficiency by considering: 3 divertors for roping 2:1 and 7 divertors for roping 4:1. Values are supposed.**Note 4:** For frequencies lower than 5 Hz, please consult your inverter supplier.**Note 5:** Max 180 sts/h - 30% ED without fans. Max 240 sts/h - 50% ED with fans activated by thermocontacts inside motor.**Note 6:** MAYR's certified brake against Overspeed in upward direction and as UCM (EN 81-20:2014, EN 81-50:2014) with reference to Lift Directive 2014/33/EU.**Note 7:** Traction sheave width: 180 mm.**Note 8:** Weight 630 kg (without sheave).*The Alberto Sassi SpA reserves the rights to change data and features without previous notice.*



TIRO/ROPING 1/1 • Corsa/Travel 30 mt

Portata Duty loads [kg]	Velocità Speed [m/s]	Puleggia Sheave [mm]	* Combinazioni funi Ropes combination	N° Funi max. Max ropes nr.	Peso cabina Cabin Weight [kg]	
630	0,63 – 2,50	450	5÷6 x ø 11	10 x ø 11	850	1050
630	0,63 – 2,50	480	4÷5 x ø 12	10 x ø 12		
630	0,63 – 2,50	520	4÷5 x ø 12/13	8 x ø 13		
630	0,63 – 2,50	560	4÷5 x ø 12/13	8 x ø 14		
630	0,63 – 2,50	600	4÷5 x ø 12/13	8 x ø 15		
800	0,63 – 2,50	360	7÷8 x ø 9	12 x ø 9	850	1200
800	0,63 – 2,50	400	6÷7 x ø 10	12 x ø 10		
800	0,63 – 2,50	450	5÷6 x ø 11	10 x ø 11		
800	0,63 – 2,50	480	4÷5 x ø 12	10 x ø 12		
800	0,63 – 2,50	520	4÷5 x ø 12/13	8 x ø 13		
800	0,63 – 2,50	560	4÷5 x ø 12/13	8 x ø 14		
800	0,63 – 2,50	600	4÷5 x ø 12/13	8 x ø 15		
1000	0,63 – 2,50	360	9÷10 x ø 9	12 x ø 9	950	1250
1000	0,63 – 2,50	400	8÷9 x ø 10	12 x ø 10		
1000	0,63 – 2,50	450	7÷8 x ø 11	10 x ø 11		
1000	0,63 – 2,50	480	6÷7 x ø 12	10 x ø 12		
1000	0,63 – 2,50	520	5÷6 x ø 13	8 x ø 13		
1000	0,63 – 2,50	560	4÷5 x ø 13/14	8 x ø 14		
1000	0,63 – 2,50	600	4÷5 x ø 14/15	8 x ø 15		
1250	0,63 – 2,50	360	10 x ø 9	12 x ø 9	1250	1500
1250	0,63 – 2,50	400	9 x ø 10	12 x ø 10		
1250	0,63 – 2,50	450	8÷9 x ø 11	10 x ø 11		
1250	0,63 – 2,50	480	7÷8 x ø 12	10 x ø 12		
1250	0,63 – 2,50	520	6÷7 x ø 13	8 x ø 13		
1600	0,63 – 2,50	360	10÷12 x ø 9	12 x ø 9	1500	1800
1600	0,63 – 2,50	400	10÷12 x ø 10	12 x ø 10		

* Altre combinazioni a richiesta
Additional combination on request

TIRO/ROPING 2/1 • Corsa/Travel 30 mt

Portata Duty loads [kg]	Velocità Speed [m/s]	Puleggia Sheave [mm]	* Combinazioni funi Ropes combination	N° Funni max. Max ropes nr.	Peso cabina Cabin Weight [kg]	
1000	0,63 – 2,50	400	4÷5 x ø 10	12 x ø 10	1100	1400
1000	0,63 – 2,50	450	4÷5 x ø 11	10 x ø 11		
1000	0,63 – 2,50	480	4÷5 x ø 11/12	10 x ø 12		
1000	0,63 – 2,50	520	3÷4 x ø 13	8 x ø 13		
1000	0,63 – 2,50	560	3÷4 x ø 13/14	8 x ø 14		
1000	0,63 – 2,50	600	3÷4 x ø 14/15	8 x ø 15		
1250	0,63 – 2,50	360	5÷7 x ø 9	12 x ø 9	1250	1500
1250	0,63 – 2,50	400	4÷5 x ø 10	10 x ø 10		
1250	0,63 – 2,50	450	4÷5 x ø 11	10 x ø 11		
1250	0,63 – 2,50	480	4÷5 x ø 11/12	10 x ø 12		
1250	0,63 – 2,50	520	3÷4 x ø 13	8 x ø 13		
1250	0,63 – 2,50	560	3÷4 x ø 13/14	8 x ø 14		
1250	0,63 – 2,50	600	3÷4 x ø 14/15	8 x ø 15		
1600	0,63 – 2,50	360	5÷7 x ø 9	12 x ø 9	1500	1700
1600	0,63 – 2,50	400	4÷5 x ø 10	12 x ø 10		
1600	0,63 – 2,50	450	4÷5 x ø 11	10 x ø 11		
1600	0,63 – 2,50	480	4÷5 x ø 11/12	10 x ø 12		
1600	0,63 – 2,50	520	3÷4 x ø 13	8 x ø 13		
1600	0,63 – 2,50	560	3÷4 x ø 13/14	8 x ø 14		
1600	0,63 – 2,50	600	3÷4 x ø 14/15	8 x ø 15		
2000	0,63 – 2,50	360	8 x ø 9	12 x ø 9	1800	2000
2000	0,63 – 2,50	400	6÷7 x ø 10	12 x ø 10		
2000	0,63 – 2,50	450	5÷6 x ø 11	10 x ø 11		
2000	0,63 – 2,50	480	5÷6 x ø 11/12	10 x ø 12		
2000	0,63 – 2,50	520	5 x ø 13	8 x ø 13		
2000	0,63 – 2,50	560	5 x ø 13/14	8 x ø 14		
2000	0,63 – 2,50	600	5 x ø 14/15	8 x ø 15		
2500	0,63 – 2,50	360	10 x ø 9	12 x ø 9	2500	3000
2500	0,63 – 2,50	400	8÷9 x ø 10	12 x ø 10		
2500	0,63 – 2,50	450	7÷8 x ø 11	10 x ø 11		
2500	0,63 – 2,50	480	7÷8 x ø 11/12	10 x ø 12		
2500	0,63 – 2,50	520	6÷7 x ø 13	8 x ø 13		

TIRO/ROPING 4/1 • Corsa/Travel 30 mt

Portata Duty loads [kg]	Velocità Speed [m/s]	Puleggia Sheave [mm]	* Combinazioni funi Ropes combination	N° Funni max. Max ropes nr.	Peso cabina Cabin Weight [kg]	
5000	0,63 – 1,00	360	10 x ø 9	12 x ø 9	4500	6000
5000	0,63 – 1,00	400	8÷9 x ø 10	12 x ø 10		
5000	0,63 – 1,00	450	7÷8 x ø 11	10 x ø 11		
5000	0,63 – 1,00	480	7÷8 x ø 11/12	10 x ø 12		
5000	0,63 – 1,00	520	6÷7 x ø 13	8 x ø 13		

* Altre combinazioni a richiesta
Additional combination on request



Tabella riassuntiva configurazioni standard G-180/ G-200/ G-300				Chart with Standard configurations G-180/ G-200/ G-300		
Portata Duty load [kg]	Macchina Machine	Ø Trazione Traction unit [mm]	Ø Rinvii Divertors [mm]	Calata funi 1/1 Dist. betw ropes 1/1 [mm]	Calata funi 2/1 Dist. betw ropes 2/1 [mm]	Max carico statico Max static load [kg]
225	G-180 T4 G-200 T1	160	240	450-1020	590-855	2350 - 2500
225	G-200 T1	210	240	450-1020	615-880	2500
320	G-180 T4 G-200 T1	160	240	450-1020	590-855	2350 - 2500
320	G-200 T1	210	240	▲	615-880	2500
320	G-180 T4 G-300 T0	160	240	450-1020	590-855	2350 - 2750
320	G-300 T0	210	240	450-1020	615-880	2750
320	G-300 T0	240	240	450-1020	620-900	2750
320	G-300 T0	320	320	▲	750-1000	2750
320	G-300 T1	320	320	415-970	750-1000	2750
450	G-200 T1	210	240	▲	615-880	2500
450	G-180 T6 G-300 T0	160	240	450-1020	590-855	2350 - 2750
450	G-300 T0	210	240	450-1020	615-880	2750
450	G-300 T1	240	240	450-1020	620-900	2750
450	G-300 T2	320	320	415-970	750-1000	2750
630	G-180 T4 G-200 T1	160	240	▲	590-855	2350 - 2500
630	G-300 T0	160	240	450-1020	590-855	2750
630	G-180 T5 G-180 T6	200	240	▲	590-855	2350
630	G-300 T0	210	240	▲	615-880	2750
630	G-300 T1	210	240	450-1020	615-880	2750
630	G-300 T2	240	240	450-1020	620-900	2750
630	G-300 T1	320	320	▲	750-1000	2750
800	G-300 T1	160	240	450-1020	590-855	2750
800	G-300 T1	210	240	▲	615-880	2750
800	G-300 T2	210	240	450-1020	615-880	2750
800	G-300 T1	240	240	▲	620-900	2750
800	G-300 T1	320	320	▲	750-1000	2750
1000	G-300 T1	160	240	▲	590-855	2750
1000	G-300 T1	210	240	▲	615-880	2750
1000	G-300 T1	240	240	▲	620-900	2750
1000	G-300 T2	320	320	▲	750-1000	2750
1250	G-300 T2	240	240	▲	620-900	2750

▲ = non disponibile / ▲ = not available - Φ Max pulegge = 320 mm / Max sheaves Φ = 320 mm

Tabella riassuntiva configurazioni standard G-400 • Chart with Standard configurations G-400					
Portata Duty load [kg]	Macchina Machine	Ø Puleggia Sheave [mm]	Ø Rinvii Divertors [mm]	Calata funi 1/1 Dist. betw ropes 1/1 [mm]	Max carico statico Max static load [kg]
480	G-400 T1	400	400	500-980	3500
630	G-400 T1	320	320	430-1040	3500
630	G-400 T2	400	400	500-980	4500
800	G-400 T3	400	400	500-980	5200
1000	G-400 T3	400	400	500-980	5200
1250	G-400 T3	320	320	430-1040	5200

Ø Max pulegge = 400 mm / Max sheaves Ø = 400 mm

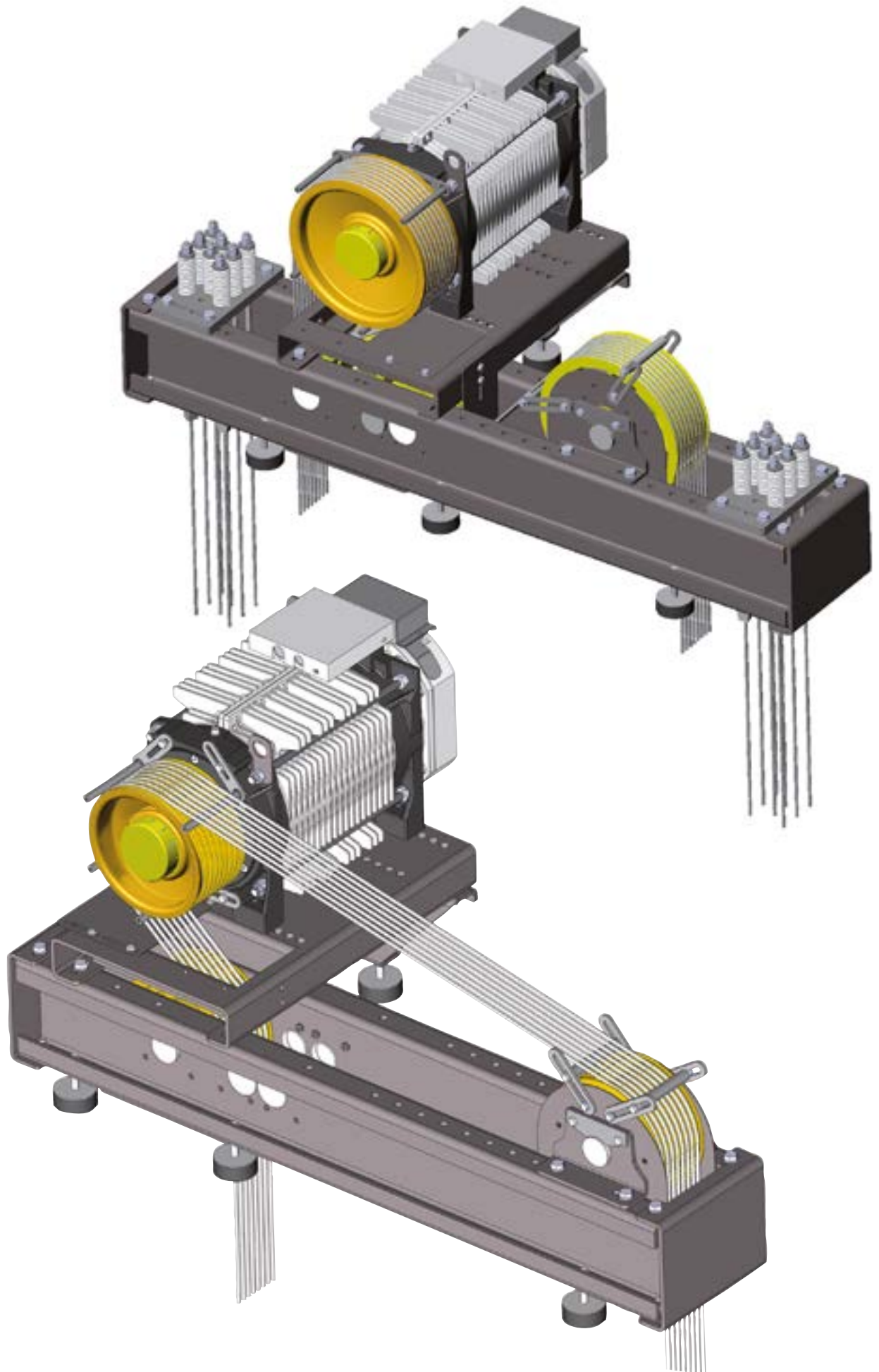
* = puleggia Ø 320 mm.
Per altre configurazioni standard vedi tabella.
* = sheave Ø 320 mm.
For additional standard configurations see chart.

G-180 / G-200 / G-300

con tiro 1/1
with roping 1/1

misure
dimension in [mm]

Machine	L	H
G-180 T4	655	660
G-180 T6	800	660
G-200 T1	655	745
G-300 T0	696	745
G-300 T1	813	745
G-300 T2	845	745

Flessione inversa possibile solo con funi metalliche ad alta resistenza.
Con funi ricoperte, dimensioni della calata funi disponibili a richiesta.

Reverse bending only possible with metallic high resistance ropes. With coated ropes the distance between ropes is available on request.

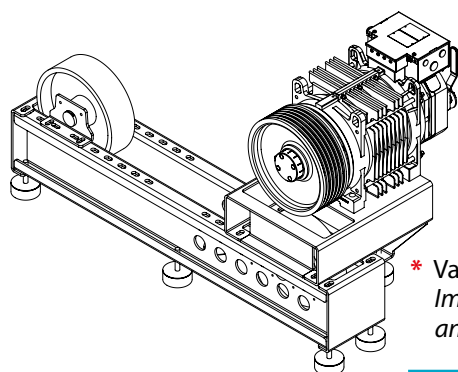
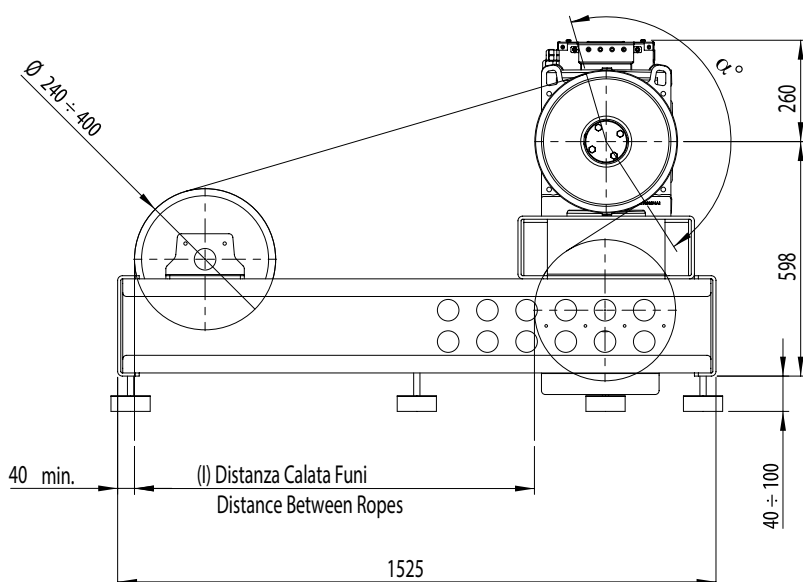
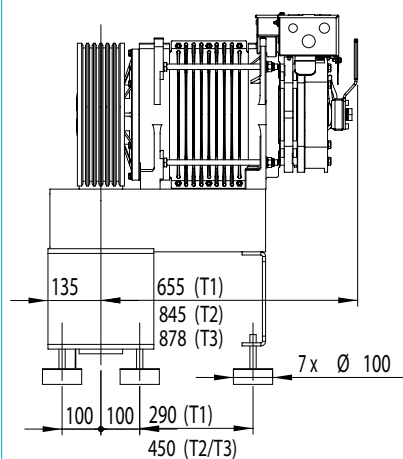
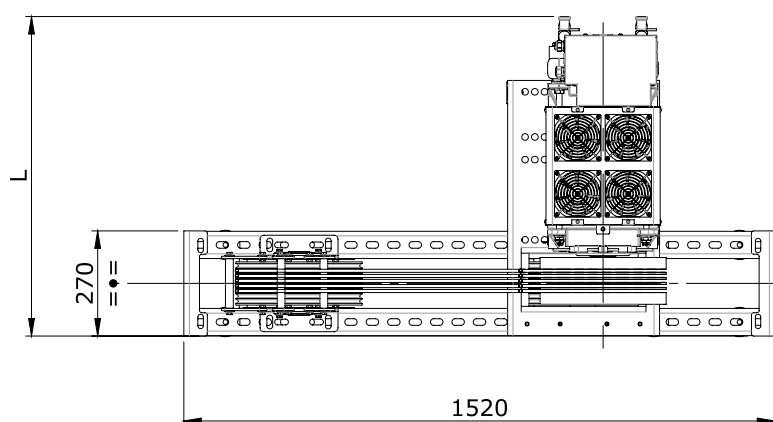
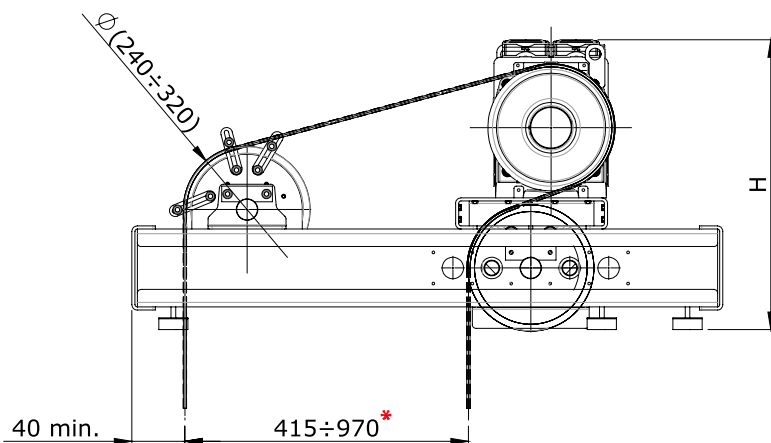

Ø mm	* l (Max) mm	α° Min.
240	1180	126°
320	1040	156°
360	1020	164°
400	1000	179°

* Valori lmax definiti con stessi diametri per trazione e rinvii
lmax values defined with the same diameters for traction sheave and divertors

G-400

Telaio piano per modernizzazioni
Flat frame for modernisation

con tiro 1/1
with roping 1/1



G-300 T1 • T2

Telaio Alto + deviazione per modernizzazioni
High frame + divertor unit for modernisations

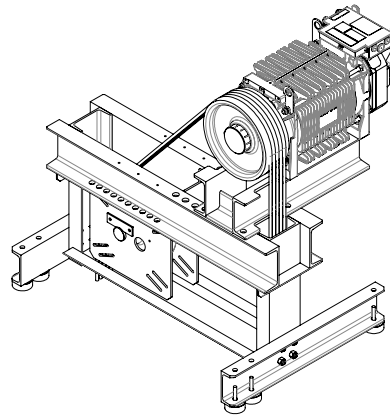
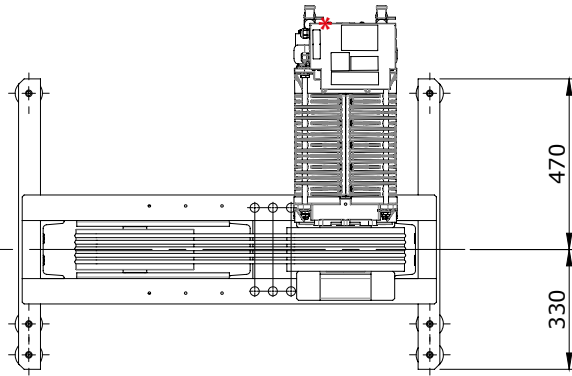
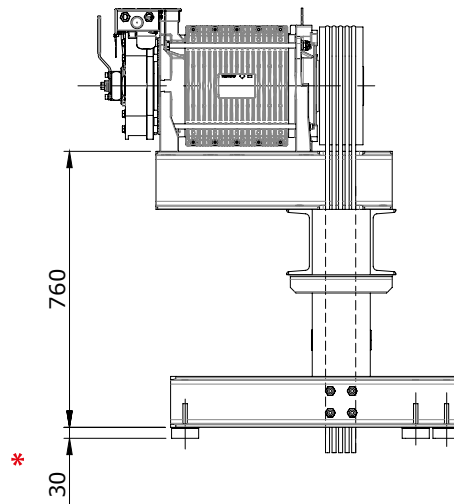
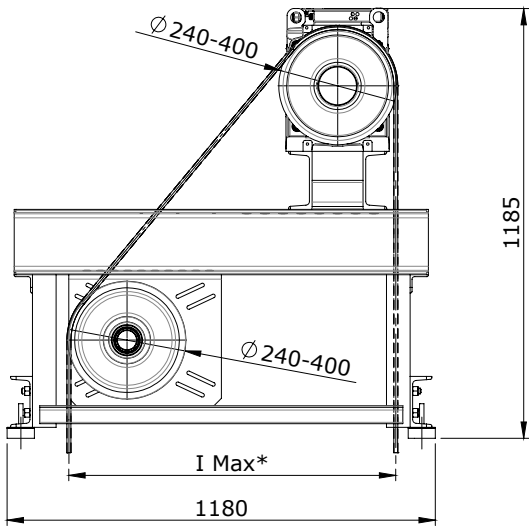

Pulegge Ø mm Sheaves Ø mm	l (max) mm
Ø 240	850
Ø 320	890
Ø 360	860
Ø 400	900

G-400 T1

Telaio piano / Flat Frame

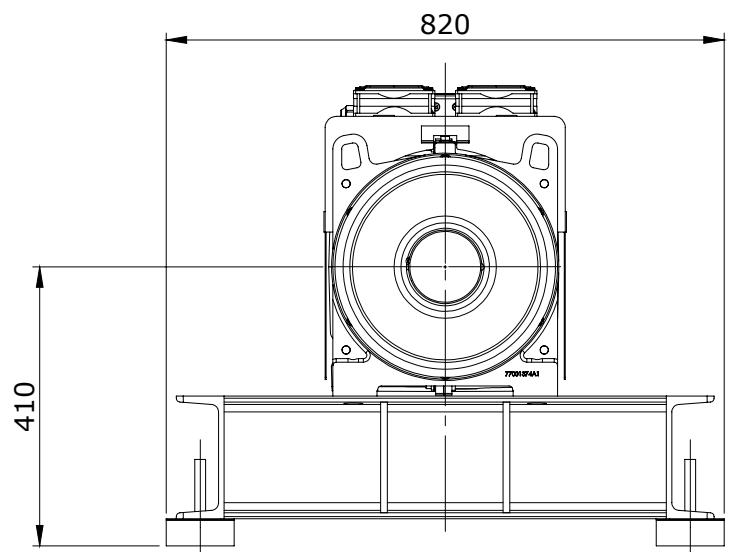
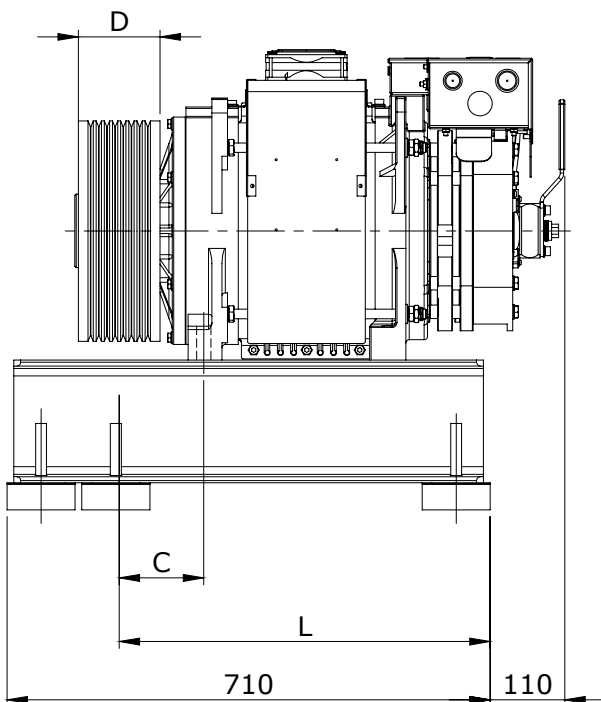

D	C	L
120	124	545
150	139	560



G-400 T2 • T3

Telaio piano / Flat Frame

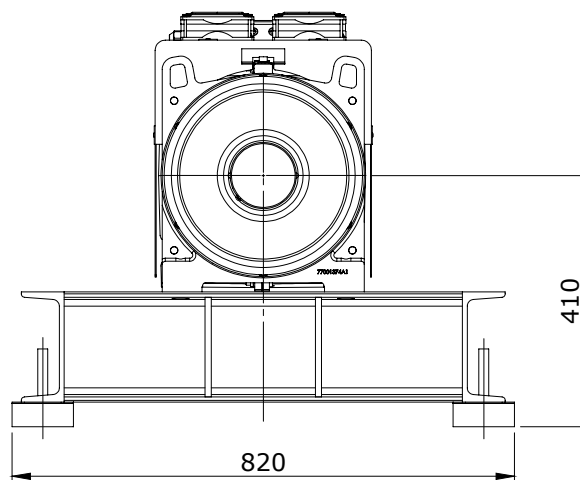
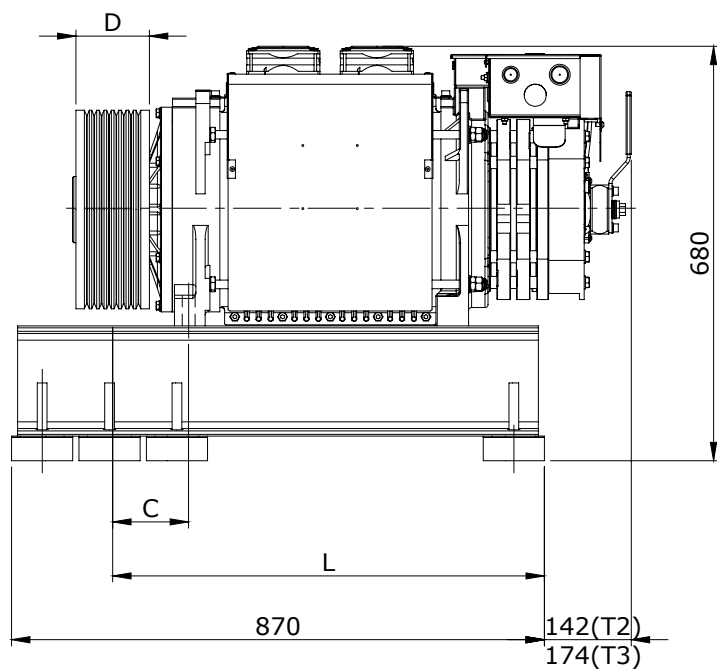

D	C	L
120	124	705
150	139	720

G-400 in Nicchia / Niche

Telaio piano per modernizzazioni

Flat frame for modernisation

con tiro 1/1
with roping 1/1

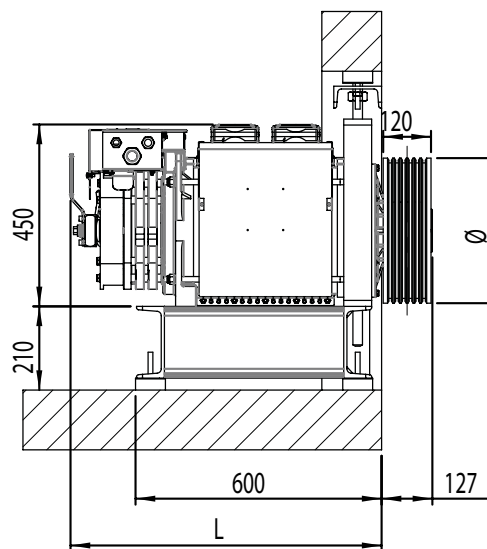
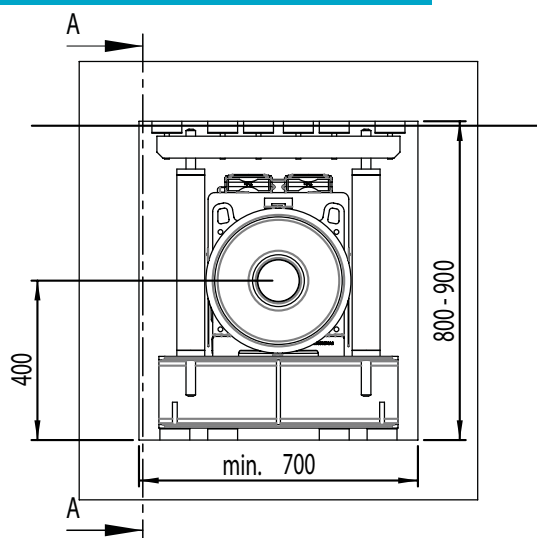

SEZIONE A-A

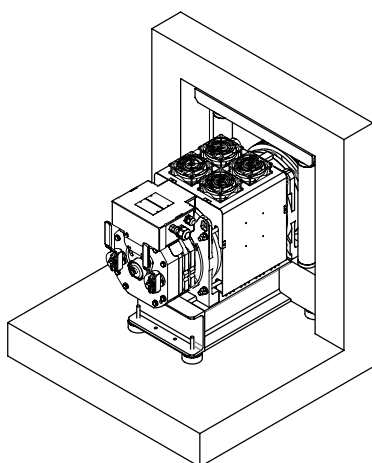

Machine	Ø	L
G-400 T1	210-600	588
G-400 T2	240-600	780
G-400 T3	240-600	815

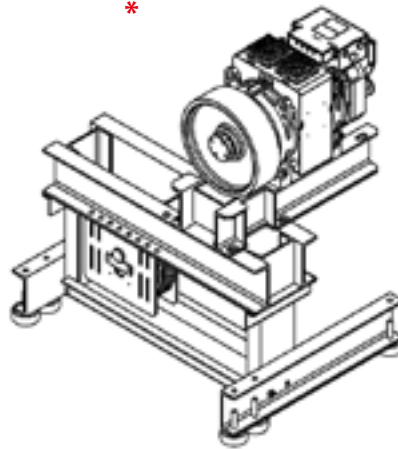
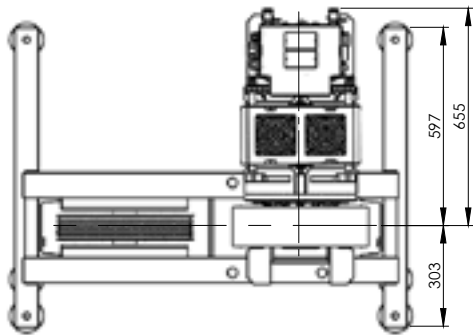
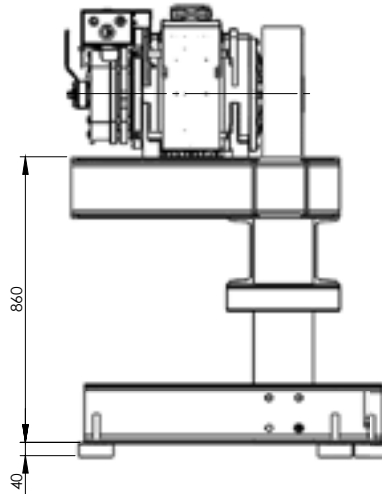
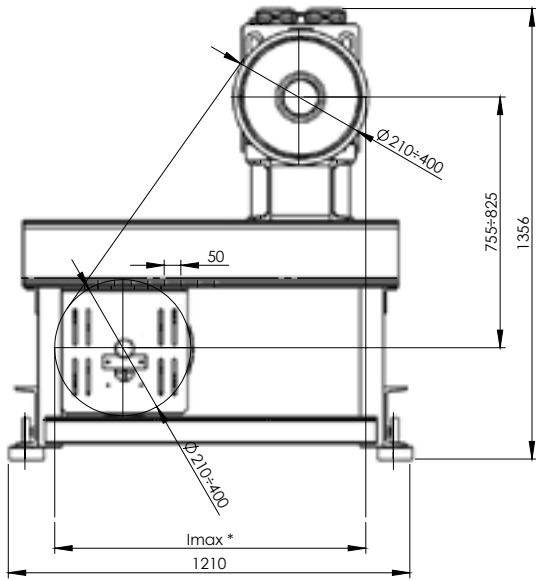

G-400 T1

Telaio Alto + deviazione per modernizzazioni
High frame + divertor unit for modernisations

Pulegge Ø mm Sheaves Ø mm	l (max) mm *
Ø210	835
Ø 240	850
Ø 320	890
Ø 360	910
Ø 400	930

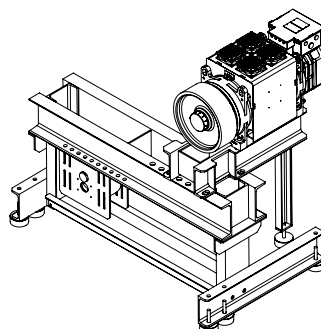
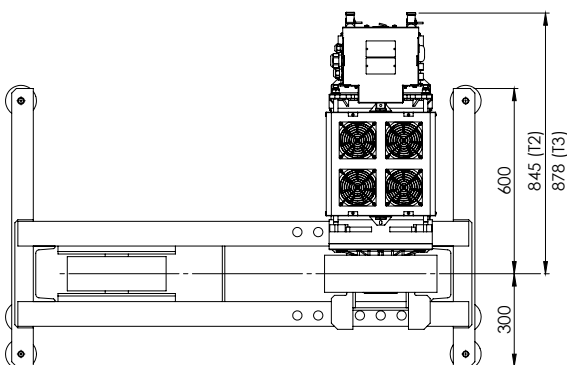
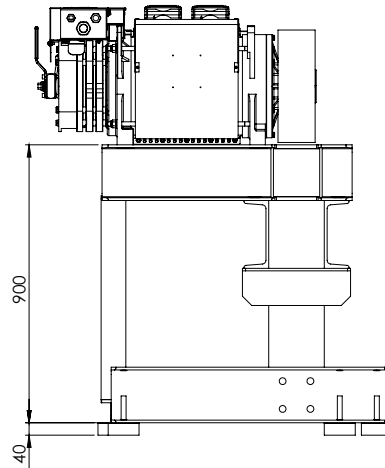
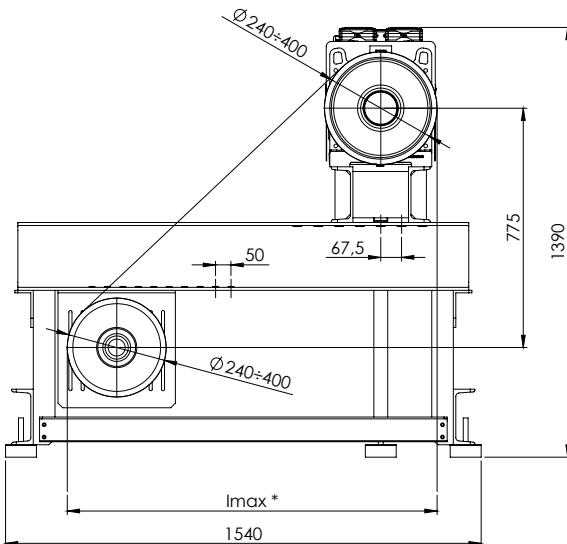

G-400 T2 • T3

Telaio Alto + deviazione per modernizzazioni
High frame + divertor unit for modernisations

Pulegge Ø mm Sheaves Ø mm	l (max) Ø mm
Ø 240	1175
Ø 320	1215
Ø 360	1235
Ø 400	1255



G-500 T1

Telaio piano / Flat Frame

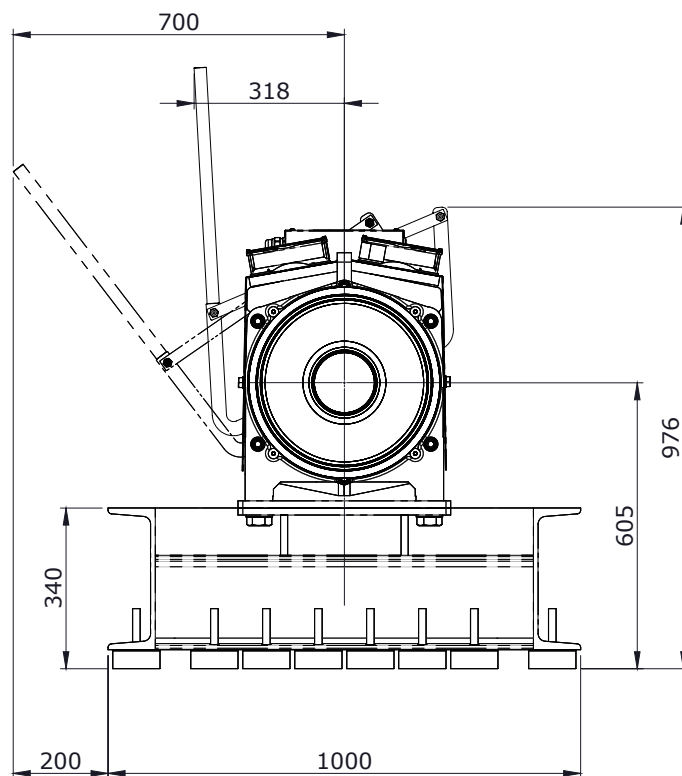
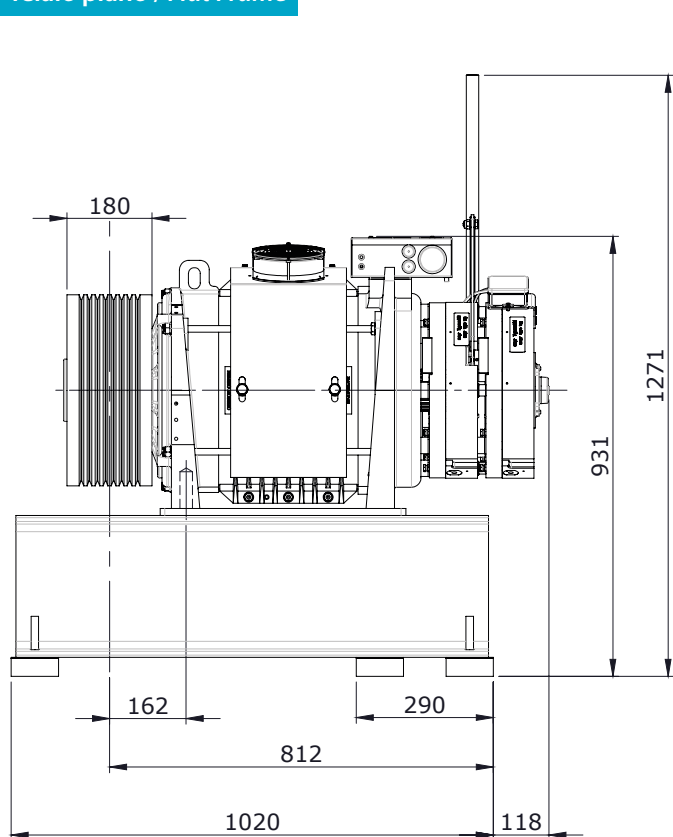

G-500 T2

Telaio piano / Flat Frame

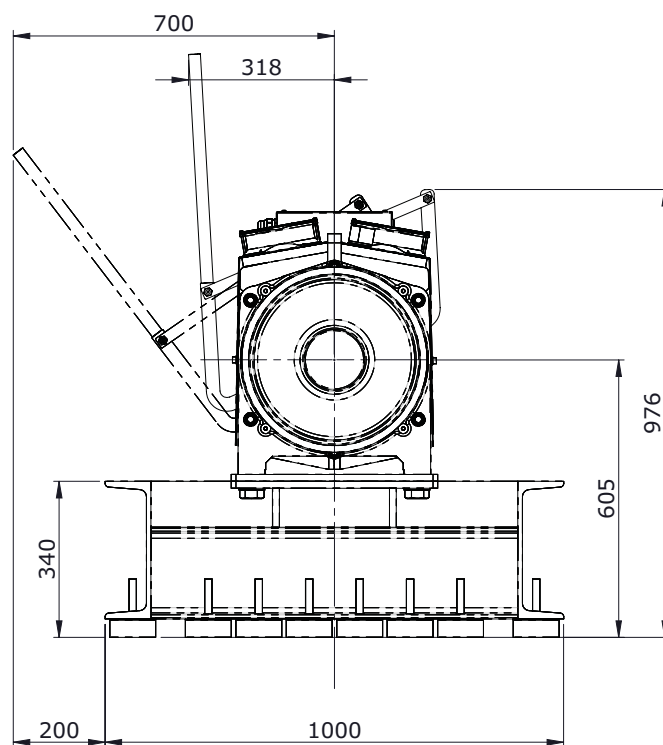
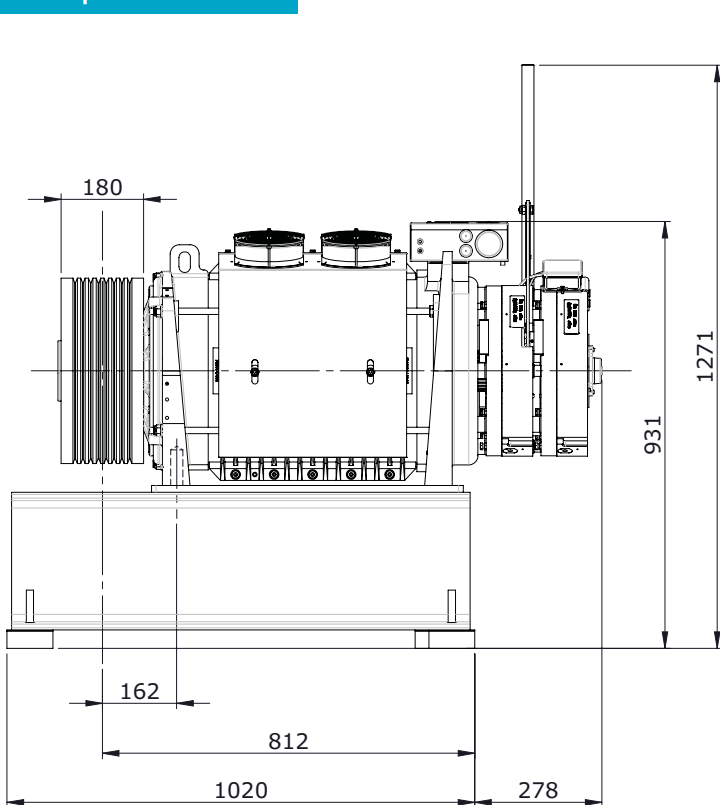



G-500 T1

Telaio con deviazione standard
Standard High Frame

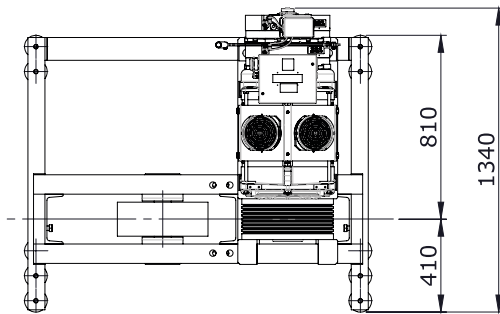
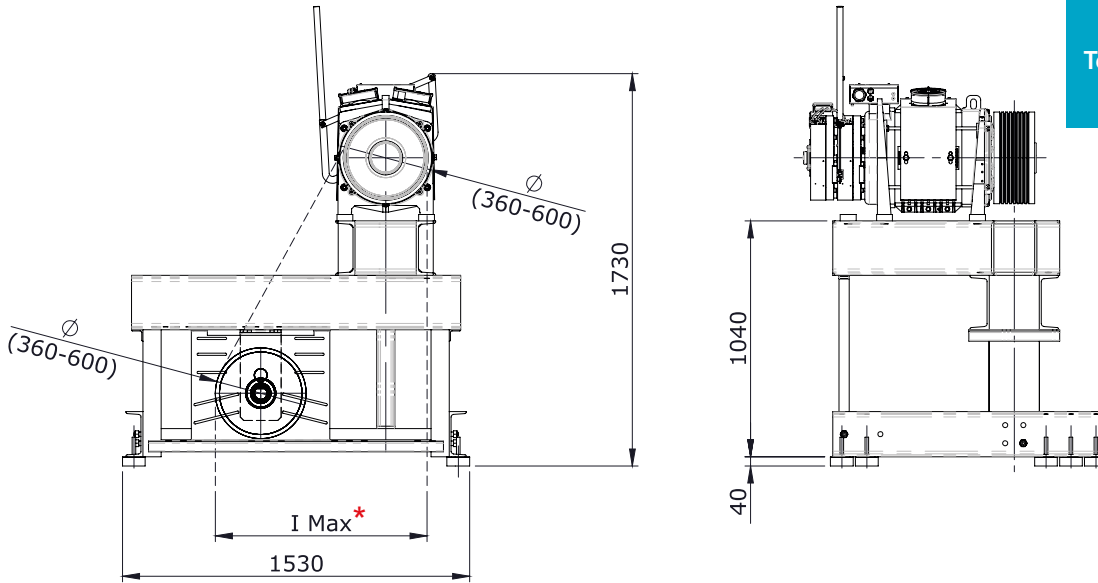

Pulegge Ø mm Sheaves Ø mm	l (max) mm *
Ø 360	1250
Ø 400	1260
Ø 450	1265
Ø 480	1270
Ø 520	1230
Ø 560	1200
Ø 600	1160

G-500 T2

Telaio con deviazione standard
Standard High Frame

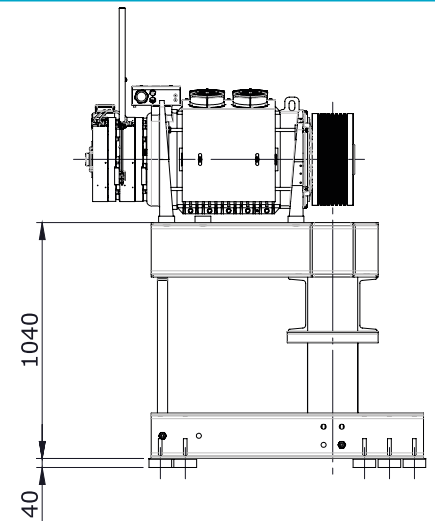
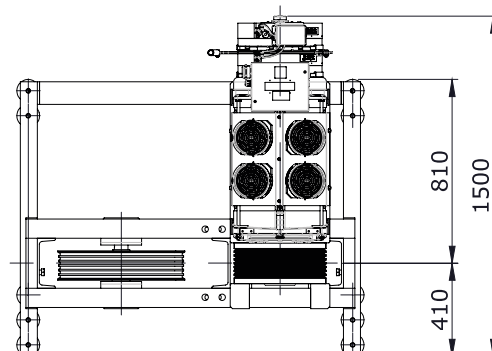
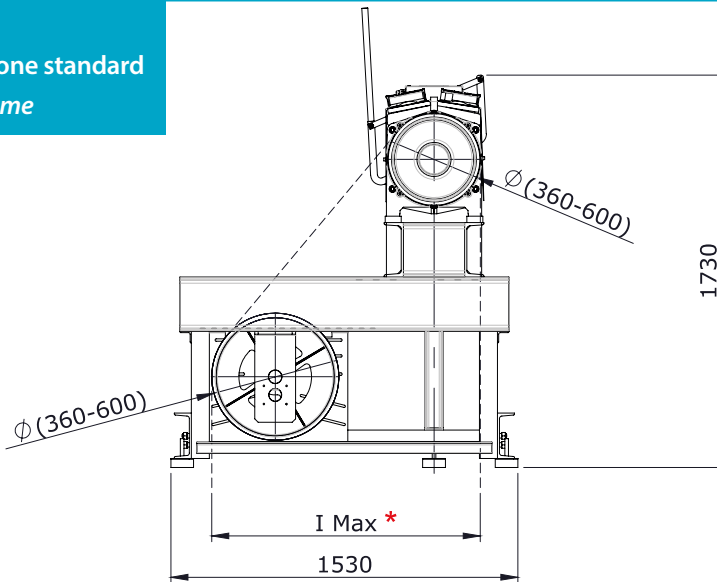

Pulegge Ø mm Sheaves Ø mm	l (max) mm *
Ø 360	1250
Ø 400	1260
Ø 450	1265
Ø 480	1270
Ø 520	1230
Ø 560	1200
Ø 600	1160



G-400

G-300

G-200

Gearless + inverter Compatibile con G-200/G-300/G-400
Gearless + inverter Compatible with G-200/G-300/G-400

Fidopak rappresenta l'accoppiata Gearless Alberto Sassi modello G-200 o G-300 o G-400 + Inverter della SMS già preconfigurati e parametrizzati per l'impianto.	Fidopak: the perfect combination between Alberto Sassi's gearless G-200 / G-300 / G-400 and pre-configured Inverters by SMS already parametrized for the installation.
Installazione veloce Plug and Play	Fast installation Plug and Play
Conforme alla norma EN81-20: 2020 contro il movimento incontrollato della cabina	Complying with norm EN81-20: 2020 against the unintended car movement
Possibilità di operare automaticamente in emergenza in caso di black out	Fidopak can operate automatically in emergency situations during black out
Filtro integrato	Integrated filter
Funzionamento dell'inverter ad anello chiuso	The inverter operates with closed loop
Le resistenze di frenatura sono incluse	Braking resistors are included
Optional: scheda ecobrake	Optional: ecobrake card

*** TIRO / ROPING 1/1 Funi / Ropes Ø 8 mm**

V (m/s)	PORTATA - DUTY LOAD - [Kg]							
			320	400	480	630	1000	
0,63	GEARLESS	TIPO TYPE	G-300 T1	G-300 T2	G-400 T1	G-400 T2	G-400 T2	
		I nom [A]	11,8	16,7	12,4	17,4	20,3	
		Potenza / Power [kW]	2	3,8	2,5	3,5	4,5	
		Puleggia / Sheave [mm]	320	320	320	320	320	
		Funi / Ropes [n° x Ø mm]	5 X 8	5 X 8	5 X 8	8 X 8	10 X 8	
	INVERTER	Inom [A]	14	20	14	20	27	
		Potenza / Power [kW]	6	11	6	11	14	
	1,0	GEARLESS	TIPO TYPE	G-300 T1	G-300 T2	G-400 T1	G-400 T2	G-400 T2
			I nom [A]	11,9	16,7	13,9	15,8	20,2
			Potenza / Power [kW]	3	3,8	3,8	5	6,4
Puleggia / Sheave [mm]			320	320	320	320	320	
Funi / Ropes [n° x Ø mm]			5 X 8	5 X 8	5 X 8	8 X 8	10 X 8	
INVERTER		Inom [A]	14	20	14	20	27	
		Potenza / Power [kW]	6	11	6	11	14	
1,6		GEARLESS	TIPO TYPE	G-300 T1	G-300 T2	G-400 T1	G-400 T2	G-400 T2
			I nom [A]	16,6	21,3	17,5	23,4	29,7
			Potenza / Power [kW]	4,5	5,8	6,1	8	10,3
	Puleggia / Sheave [mm]		320	320	320	320	320	
	Funi / Ropes [n° x Ø mm]		5 X 8	5 X 8	5 X 8	8 X 8	10 X 8	
	INVERTER	Inom [A]	20	27	20	27	35	
		Potenza / Power [kW]	11	14	11	14	22	

*** TIRO / ROPING 2/1 Funi / Ropes Ø 6,5 mm**

V (m/s)	PORTATA - DUTY LOAD - [Kg]						
			400	480	630	1000	
0,63	GEARLESS	TIPO TYPE	G-200 TS	G-200 TS	G-300 TS	G-300 T1	
		I nom [A]	8,4	13,8	15	16,5	
		Potenza / Power [kW]	2,2	3	4	4,5	
		Puleggia / Sheave [mm]	240	240	240	240	
		Funi / Ropes [n° x Ø mm]	6 X 6,5	6 X 6,5	8 X 6,5	8 X 6,5	
	INVERTER	Inom [A]	14	14	20	20	
		Potenza / Power [kW]	6	6	11	11	
	1,0	GEARLESS	TIPO TYPE	G-200 TS	G-200 TS	G-300 TS	G-300 T1
			I nom [A]	13,5	13,5	15,7	20,6
			Potenza / Power [kW]	4,4	4,4	5	7
Puleggia / Sheave [mm]			240	240	240	240	
Funi / Ropes [n° x Ø mm]			6 X 6,5	6 X 6,5	8 X 6,5	8 X 6,5	
INVERTER		Inom [A]	14	14	20	27	
		Potenza / Power [kW]	6	6	11	14	

* CONFIGURAZIONI TIPO, ALTRE OPZIONI DISPONIBILI: CONSULTARE I NOSTRI UFFICI

* TYPICAL CONFIGURATIONS, FOR FURTHER OPTIONS PLEASE CONTACT OUR OFFICES

ECOBRAKE

Scheda elettronica che, dopo un tempo iniziale, riduce la tensione di alimentazione al valore di mantenimento
Electronic card that, after an initial time, reduces power voltage at the maintenance value



Dimensione e peso <i>Dimension and weight</i>	146 x 104 x 42 mm 450 g circa/approximately
Tensione di ingresso <i>Input voltage</i>	220 ÷ 240 V AC ± 10%
Tensione di uscita <i>Output voltage</i>	48 ÷ 205 V DC
Corrente di uscita <i>Output current</i>	max 5 A

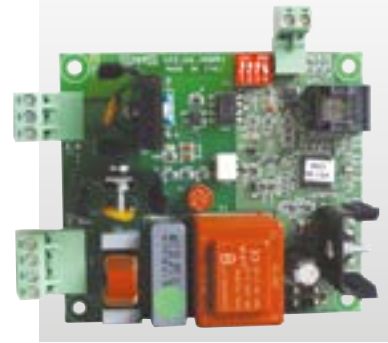

Scheda / Card 100 x 88

ALIMENTATORE POWER SUPPLY

Scheda elettronica che fornisce il corretto valore di tensione continua al freno elettromagnetico
Electronic card that provides the correct value of continuous voltage to the electromagnetic brake

Dimensione e peso <i>Dimension and weight</i>	100 x 88 x 35 mm 450 g circa / approximately	146 x 104 x 42 mm 450 g circa / approximately
Tensione di ingresso <i>Input voltage</i>	220 ÷ 240 V AC ± 10%	220 ÷ 240 V AC ± 10%
Tensione di uscita <i>Output voltage</i>	50 ÷ 205 V DC	48 ÷ 205 V DC
Corrente di uscita <i>Output current</i>	max 3 A	max 5 A

ACCESSORI GEARLESS / GEARLESS ACCESSORIES

GEARLESS TYPES	G-100	G-180	G-200	G-300	G-400	G-500
INVERTER / INVERTER	▲	▲	▲	▲	▲	▲
ENCODER / ENCODER	●	●	●	●	●	●
CAVI ALIMENTAZIONE MOTORE CABLE FOR MOTOR SUPPLY	▲	▲	▲	▲	▲	▲
CARTER PULEGGIA / CARTER FOR SHEAVE	●	▲	▲	▲	▲	▲
ANTINTRUSIONE / ANTI-INTRUSION	●	●	●	●	●	●
TEMPRA PULEGGIA / SHEAVE TREATMENT	●▲	●▲	●▲	●▲	●▲	▲
LEVE APERTURA MANUALE FRENO LEVERS FOR BRAKE HAND RELEASE	▲	▲	▲	▲	▲	▲
VENTILAZIONE FORZATA / FORCED VENTILATION	■	●▲	●▲	●▲	●▲	●▲
TELAIO PIANO CON DEVIAZIONE FLAT FRAME WITH DIVERTOR	■	▲	▲	▲	▲	▲
TELAIO ALTO CON DEVIAZIONE HIGH FRAME WITH DIVERTOR	■	▲	▲	▲	▲	▲
TELMO (KIT TELAIO PER MODERNIZZAZION TELMO (FRAME SET FOR MODERNISATION)	■	▲	▲	▲	▲	■
ANTIVIBRANTI / VIBRATION DAMPERS	■	▲	▲	▲	▲	▲

● DI SERIE / STANDARD

▲ A RICHIESTA / ON REQUEST

■ NON DISPONIBILE / NOT AVAILABLE

